

DATE REVISED	DATE REVISED	FED. RD. DIST. NO.	STATE	JOB NO.	SHEET NO.	TOTAL SHEETS
		6	ARK.	110747	1	30
BAYOU DEVIEU - FORREST CITY (S)						

PROJECT LOCATION

" A FULLY CONTROLLED ACCESS FACILITY "
 ARKANSAS DEPARTMENT OF TRANSPORTATION
 CONSTRUCTION PLANS FOR STATE HIGHWAY



BAYOU DEVIEU - FORREST CITY (S)

MONROE & ST. FRANCIS COUNTIES

ROUTE I-40 SECTIONS 43 & 51

JOB 110747

FEDERAL AID PROJ. NHPP-NHFP-40-4(90)

NOT TO SCALE

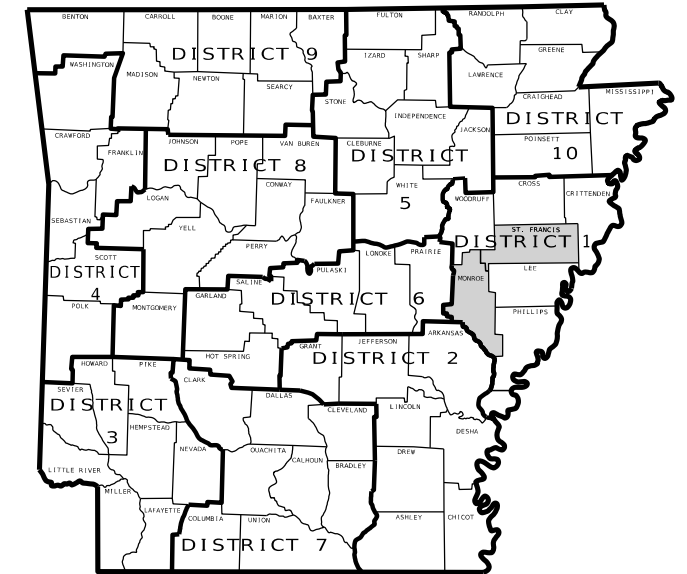

ARKANSAS HIGHWAY DISTRICT 1

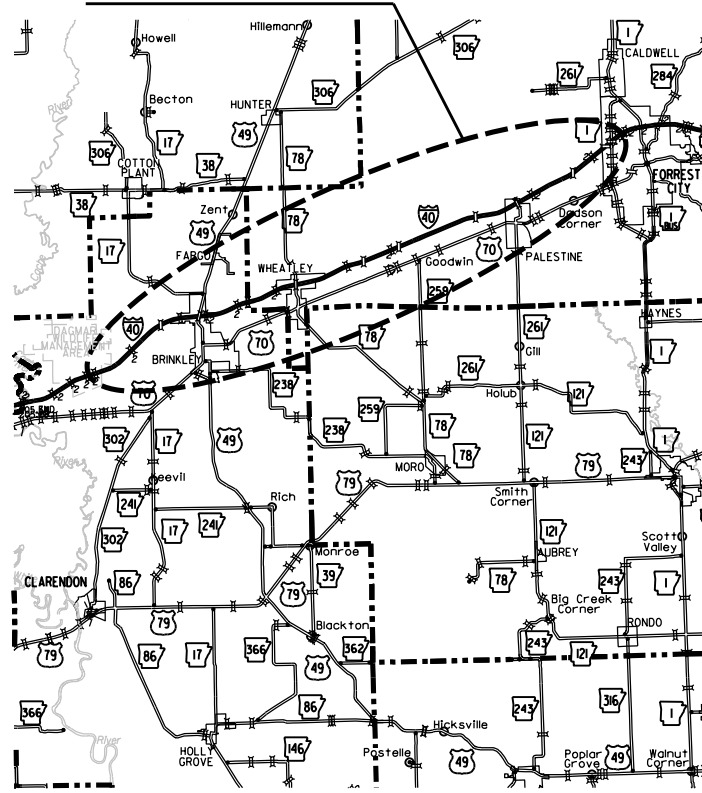

VICINITY MAP

FOR EXCEPTIONS TO JOB NO. 110747
 AND FOR BRIDGE DATA, SEE SHEET NO. 2

BEGIN JOB 110747
 LOG MILE 209.298

END JOB 110747
 LOG MILE 239.749



LENGTH OF PROJECT CALCULATED ALONG Q

GROSS LENGTH OF PROJECT	160781.28 FEET OR	30.451 MILES
NET " " ROADWAY	157180.32 " "	29.769 MILES
NET " " BRIDGES	1582.41 " "	0.300 MILES
NET " " PROJECT	158762.73 " "	30.069 MILES

	BEGIN PROJECT	MID-POINT OF PROJECT	END PROJECT
LATITUDE	N 34° 52' 08"	N 34° 56' 39"	N 35° 01' 58"
LONGITUDE	W 91° 17' 39"	W 91° 02' 54"	W 90° 48' 20"



DATE REVISED	DATE REVISED	FED. RD. DIST. NO.	STATE	JOB NO.	SHEET NO.	TOTAL SHEETS
		6	ARK.	110747	2	30
BRIDGE DATA						

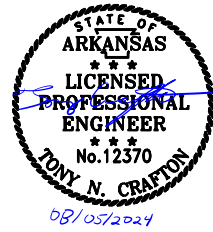

**ROADWAY EXCEPTIONS:
3600.96 FT. = 0.682 MILES**

- | | |
|--|---|
| <p>② LOG MILE 209.298 BRIDGE END
1356.96' EXCEPTION LENGTH
1322'-2½" BRIDGE NO. A3724
40'-0" CLEAR ROADWAY
LOG MILE 209.555 APPROACH SLAB END</p> <p>③ & ④ LOG MILE 211.605 APPROACH SLAB END
205.92' EXCEPTION LENGTH
134'-0" BRIDGE NO. A3727 & B3727
40'-0" CLEAR ROADWAY
LOG MILE 211.644 APPROACH SLAB END</p> <p>⑤ LOG MILE 215.984 APPROACH SLAB END
327.36' EXCEPTION LENGTH
260'-2¾" BRIDGE NO. B3731
40'-0" CLEAR ROADWAY
LOG MILE 216.046 APPROACH SLAB END</p> <p>⑦ LOG MILE 217.754 APPROACH SLAB END
126.72' EXCEPTION LENGTH
50'-0" BRIDGE NO. B3732
40'-0" CLEAR ROADWAY
LOG MILE 217.778 APPROACH SLAB END</p> <p>⑧ LOG MILE 217.761 APPROACH SLAB END
126.72' EXCEPTION LENGTH
50'-0" BRIDGE NO. A3732
40'-0" CLEAR ROADWAY
LOG MILE 217.785 APPROACH SLAB END</p> <p>⑨ & ⑩ LOG MILE 219.888 APPROACH SLAB END
200.64' EXCEPTION LENGTH
125'-0" BRIDGE NO. A3766 & B3766
40'-0" CLEAR ROADWAY
LOG MILE 219.926 APPROACH SLAB END</p> | <p>⑪ & ⑫ LOG MILE 226.184 APPROACH SLAB END
195.36' EXCEPTION LENGTH
125'-0" BRIDGE NO. A3769 & B3769
41'-0" CLEAR ROADWAY
LOG MILE 226.221 APPROACH SLAB END</p> <p>⑬ & ⑭ LOG MILE 233.965 APPROACH SLAB END
865.92' EXCEPTION LENGTH
792'-0" BRIDGE NO. A6518 & B6518
40'-0" CLEAR ROADWAY
LOG MILE 234.129 APPROACH SLAB END</p> <p>⑮ LOG MILE 237.749 APPROACH SLAB END
158.40' EXCEPTION LENGTH
90'-0" BRIDGE NO. B3614
38'-1" CLEAR ROADWAY
LOG MILE 237.779 APPROACH SLAB END</p> <p>⑯ LOG MILE 237.729 APPROACH SLAB END
158.40' EXCEPTION LENGTH
90'-0" BRIDGE NO. A3614
38'-1" CLEAR ROADWAY
LOG MILE 237.759 APPROACH SLAB END</p> <p>⑰ LOG MILE 239.438 APPROACH SLAB END
163.68' EXCEPTION LENGTH
90'-0" BRIDGE NO. B3617
38'-1" CLEAR ROADWAY
LOG MILE 239.469 APPROACH SLAB END</p> <p>⑱ LOG MILE 239.417 APPROACH SLAB END
163.68' EXCEPTION LENGTH
90'-0" BRIDGE NO. A3617
38'-1" CLEAR ROADWAY
LOG MILE 239.448 APPROACH SLAB END</p> |
|--|---|

BRIDGE CONSTRUCTION DATA

- ① LOG MILE 209.298 BRIDGE END
1322'-2½" BRIDGE NO. B3724
40'-0" CLEAR ROADWAY
LOG MILE 209.555 APPROACH SLAB END
RETAIN AND JOINT REPAIR
- ⑥ LOG MILE 215.985 APPROACH SLAB END
260'-2¾" BRIDGE NO. A3731
40'-0" CLEAR ROADWAY
LOG MILE 216.047 APPROACH SLAB END
RETAIN AND JOINT REPAIR

DATE REVISED	DATE REVISED	FED. RD. DIST. NO.	STATE	JOB NO.	SHEET NO.	TOTAL SHEETS
		6	ARK.	110747	3	30
INDEX OF SHEETS AND STANDARD DRAWINGS						



INDEX OF SHEETS

SHEET NO.	TITLE	BRIDGE NO.	DRWG. NO.
1	TITLE SHEET		
2	BRIDGE DATA		
3	INDEX OF SHEETS AND STANDARD DRAWINGS		
4	GOVERNING SPECIFICATIONS AND GENERAL NOTES		
5 - 7	TYPICAL SECTIONS OF IMPROVEMENT		
8 - 11	SPECIAL DETAILS		
12 - 16	MAINTENANCE OF TRAFFIC DETAILS		
17 - 22	PERMANENT PAVEMENT MARKING DETAILS		
23 - 26	QUANTITIES		
27	SCHEDULE OF BRIDGE QUANTITIES	B3724 & A3731	64155
28	SUMMARY OF QUANTITIES AND REVISIONS		
29	BRIDGE PRESERVATION DATA TABLE - DISTRICT 1	B3724 & A3731	64156
30	BACKWALL MODIFICATION DETAILS	A3731	64157

BRIDGE STANDARD DRAWINGS

DRWG. NO.	TITLE	DATE
55064	STANDARD DETAILS FOR JOINT REPAIRS & MODIFICATION	11-07-19

ROADWAY STANDARD DRAWINGS

DRWG. NO.	TITLE	DATE
PM-1	PAVEMENT MARKING DETAILS	02-27-20
PM-2	PERMANENT PAVEMENT MARKING ON ACCESS CONTROLLED ROADWAYS	05-14-20
TC-1	STANDARD TRAFFIC CONTROLS FOR HIGHWAY CONSTRUCTION	08-14-25
TC-2	STANDARD TRAFFIC CONTROLS FOR HIGHWAY CONSTRUCTION	08-14-25
TC-3	STANDARD TRAFFIC CONTROLS FOR HIGHWAY CONSTRUCTION	08-14-25
TC-6	STANDARD TRAFFIC CONTROLS FOR HIGHWAY CONSTRUCTION	08-14-25

DATE REVISED	DATE REVISED	FED. RD. DIST. NO.	STATE	JOB NO.	SHEET NO.	TOTAL SHEETS
		6	ARK.	110747	4	30
GOVERNING SPECIFICATIONS AND GENERAL NOTES						

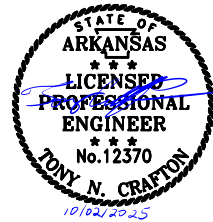

GOVERNING SPECIFICATIONS

ARKANSAS STATE HIGHWAY COMMISSION STANDARD SPECIFICATIONS FOR HIGHWAY CONSTRUCTION, EDITION OF 2014, AND THE FOLLOWING SPECIAL PROVISIONS AND SUPPLEMENTAL SPECIFICATIONS:

NUMBER	TITLE
ERRATA	ERRATA FOR THE BOOK OF STANDARD SPECIFICATIONS
FHWA-1273	REQUIRED CONTRACT PROVISIONS FEDERAL-AID CONSTRUCTION CONTRACTS
FHWA-1273	SUPPLEMENT - EQUAL EMPLOYMENT OPPORTUNITY - NOTICE TO CONTRACTORS
FHWA-1273	SUPPLEMENT - SPECIFIC EQUAL EMPLOYMENT OPPORTUNITY RESPONSIBILITIES (23 U.S.C. 140)
FHWA-1273	SUPPLEMENT - EQUAL EMPLOYMENT OPPORTUNITY - GOALS AND TIMETABLES
FHWA-1273	SUPPLEMENT - EQUAL EMPLOYMENT OPPORTUNITY - FEDERAL STANDARDS
FHWA-1273	SUPPLEMENT - POSTERS AND NOTICES REQUIRED FOR FEDERAL-AID PROJECTS
FHWA-1273	SUPPLEMENT - WAGE RATE DETERMINATION
FHWA-1273	SUPPLEMENT - TRAINING PROGRAM - JOB 110747
100-3	CONTRACTOR'S LICENSE
100-4	DEPARTMENT NAME CHANGE
102-2	ISSUANCE OF PROPOSALS
102-3	PREQUALIFICATION OF BIDDERS
103-2	CONTACT INFORMATION FOR MOTORIST DAMAGE CLAIMS
105-4	MAINTENANCE DURING CONSTRUCTION
107-2	RESTRAINING CONDITIONS
108-1	LIQUIDATED DAMAGES
108-2	WORK ALLOWED PRIOR TO ISSUANCE OF WORK ORDER
303-1	AGGREGATE BASE COURSE
306-1	QUALITY CONTROL AND ACCEPTANCE
400-1	TACK COATS
400-4	DESIGN AND QUALITY CONTROL OF ASPHALT MIXTURES
400-5	PERCENT AIR VOIDS FOR ACHM MIX DESIGNS
400-6	LIQUID ANTI-STRIP ADDITIVE
400-7	TRACKLESS TACK
404-3	DESIGN OF ASPHALT MIXTURES
409-2	ASPHALT LABORATORY FACILITY
410-1	CONSTRUCTION REQUIREMENTS AND ACCEPTANCE OF ASPHALT CONCRETE PLANT MIX COURSES
410-2	DEVICES FOR MEASURING DENSITY FOR ROLLING PATTERNS
410-4	EVALUATION OF ACHM SUBLOT REPLACEMENT MATERIAL
416-1	RECYCLED ASPHALT PAVEMENT
603-1	LANE CLOSURE NOTIFICATION
604-1	RETROREFLECTIVE SHEETING FOR TRAFFIC CONTROL DEVICES IN CONSTRUCTION ZONES
604-3	TRAFFIC CONTROL DEVICES IN CONSTRUCTION ZONES (MASH)
800-1	STRUCTURES
JOB 110747	ASPHALT MIXTURES WITH PG 76-22 BINDER
JOB 110747	ASSESSMENT OF WORKING DAYS - MAINTENANCE OF TRAFFIC
JOB 110747	BIDDING REQUIREMENTS AND CONDITIONS
JOB 110747	BRIDGE BACKWALL MODIFICATION
JOB 110747	BROADBAND INTERNET SERVICE FOR FIELD OFFICE
JOB 110747	BUY AMERICA - CONSTRUCTION MATERIALS
JOB 110747	CARGO PREFERENCE ACT REQUIREMENTS
JOB 110747	COLD MILLING - MILL AND INLAY
JOB 110747	CONSTRUCTION PROJECT INFORMATION SIGN
JOB 110747	COORDINATION OF WORK
JOB 110747	CULVERT REHABILITATION
JOB 110747	DESIGN AND QUALITY CONTROL OF ASPHALT MIXTURES
JOB 110747	DOCUMENTATION OF PAYMENTS MADE TO DISADVANTAGED BUSINESS ENTERPRISES
JOB 110747	ENHANCED THERMOPLASTIC PAVEMENT MARKING
JOB 110747	FLEXIBLE BEGINNING OF WORK - CALENDAR DAY CONTRACT
JOB 110747	INSURANCE, CONSTRUCTION, AND FLAGGING REQUIREMENTS ON RAILROAD PROPERTY (UPRR)
JOB 110747	LIQUIDATED DAMAGES PROCEDURE FOR BID LETTINGS
JOB 110747	LONGITUDINAL JOINT DENSITIES FOR ACHM SURFACE COURSES
JOB 110747	MAINTENANCE OF TRAFFIC
JOB 110747	MANDATORY ELECTRONIC CONTRACT
JOB 110747	MANDATORY ELECTRONIC DOCUMENT SUBMITTAL
JOB 110747	MOBILE SPEED NOTIFICATION SYSTEM (SPECIAL)
JOB 110747	PARTNERING REQUIREMENTS
JOB 110747	PERCENT WITHIN LIMITS
JOB 110747	PLASTIC PIPE
JOB 110747	PRICE ADJUSTMENT FOR ASPHALT BINDER
JOB 110747	PRICE ADJUSTMENT FOR FUEL
JOB 110747	PROHIBITION OF CERTAIN TELECOMMUNICATIONS AND VIDEO SURVEILLANCE SERVICES OR EQUIPMENT
JOB 110747	RECLAIMED AGGREGATE
JOB 110747	SEQUENCE OF CONSTRUCTION
JOB 110747	SITE USE (A+C METHOD) - CALENDAR DAY CONTRACT
JOB 110747	SPALL REPAIR OF PORTLAND CEMENT CONCRETE PAVEMENT
JOB 110747	SUBMISSION OF ASPHALT CONCRETE HOT MIX ACCEPTANCE TEST RESULTS
JOB 110747	TRAFFIC CONTROL DEVICES IN CONSTRUCTION ZONES
JOB 110747	UTILITY ADJUSTMENTS
JOB 110747	VALUE ENGINEERING
JOB 110747	WARM MIX ASPHALT
JOB 110747	WATER POLLUTION CONTROL
JOB 110747	WORK ZONE LAW ENFORCEMENT

GENERAL NOTES

- ALL LAND MONUMENTS LOCATED WITHIN THE CONSTRUCTION AREA SHALL BE PROTECTED IN ACCORDANCE WITH SECTION 107.12 OF THE STANDARD SPECIFICATIONS.
- ALL PIPE LINES, POWER, TELEPHONE, AND TELEGRAPH LINES TO BE MOVED OR LOWERED BY THE RESPECTIVE OWNERS AS PER AGREEMENT WITH SUCH OWNERS.
- ANY EQUIPMENT OR APPURTENANCE THAT INTERFERES WITH THE PROPOSED CONSTRUCTION AND WHICH MAY BE THE PROPERTY OF UTILITY SERVICE ORGANIZATIONS SHALL BE MOVED BY THE OWNERS UNLESS OTHERWISE PROVIDED.
- ALL LAND MONUMENTS LOCATED WITHIN THE CONSTRUCTION AREA SHALL BE PROTECTED IN ACCORDANCE WITH SECTION 107.12 OF THE STANDARD SPECIFICATIONS.
- ALL TREES THAT DO NOT DIRECTLY INTERFERE WITH THE PROPOSED CONSTRUCTION SHALL BE SPARED AS DIRECTED BY THE ENGINEER. CARE AND DISCRETION SHALL BE USED TO ENSURE THAT ALL TREES NOT TO BE REMOVED SHALL BE HARMED AS LITTLE AS POSSIBLE DURING THE CONSTRUCTION OPERATIONS.
- THE CONTRACTOR SHALL BE RESPONSIBLE FOR PROVIDING A FENCE TO CONTROL LIVESTOCK IN AREAS WHERE PASTURES ARE SEVERED. WIRE FENCE MAY BE CONSTRUCTED INITIALLY, OR IN LIEU THEREOF, THE CONTRACTOR AT HIS OWN EXPENSE, MAY ELECT TO PROVIDE TEMPORARY FENCING SUITABLE TO CONTAIN LIVESTOCK.
- THE SEQUENCE AS SHOWN ON THE MAINTENANCE OF TRAFFIC PLANS IS A GENERAL OUTLINE FOR THE CONSTRUCTION OF THIS PROJECT, AND IN NO WAY IS IT INTENDED TO COVER EVERY ITEM IN THE PROJECT. ITEMS NOT CRITICAL TO THE CONSTRUCTION SEQUENCE MAY BE CONSTRUCTED IN ANY STAGE AS APPROVED BY THE RESIDENT ENGINEER.
- STRINGLINE WILL BE USED TO MAINTAIN A UNIFORM HORIZONTAL ALIGNMENT.

R110747_03_GN_001.DGN CREATED: 7/6/2016 9:51/2025

DATE REVISED	DATE REVISED	FED. RD. DIST. NO.	STATE	JOB NO.	SHEET NO.	TOTAL SHEETS
		6	ARK.	110747	5	30
TYPICAL SECTIONS OF IMPROVEMENT						

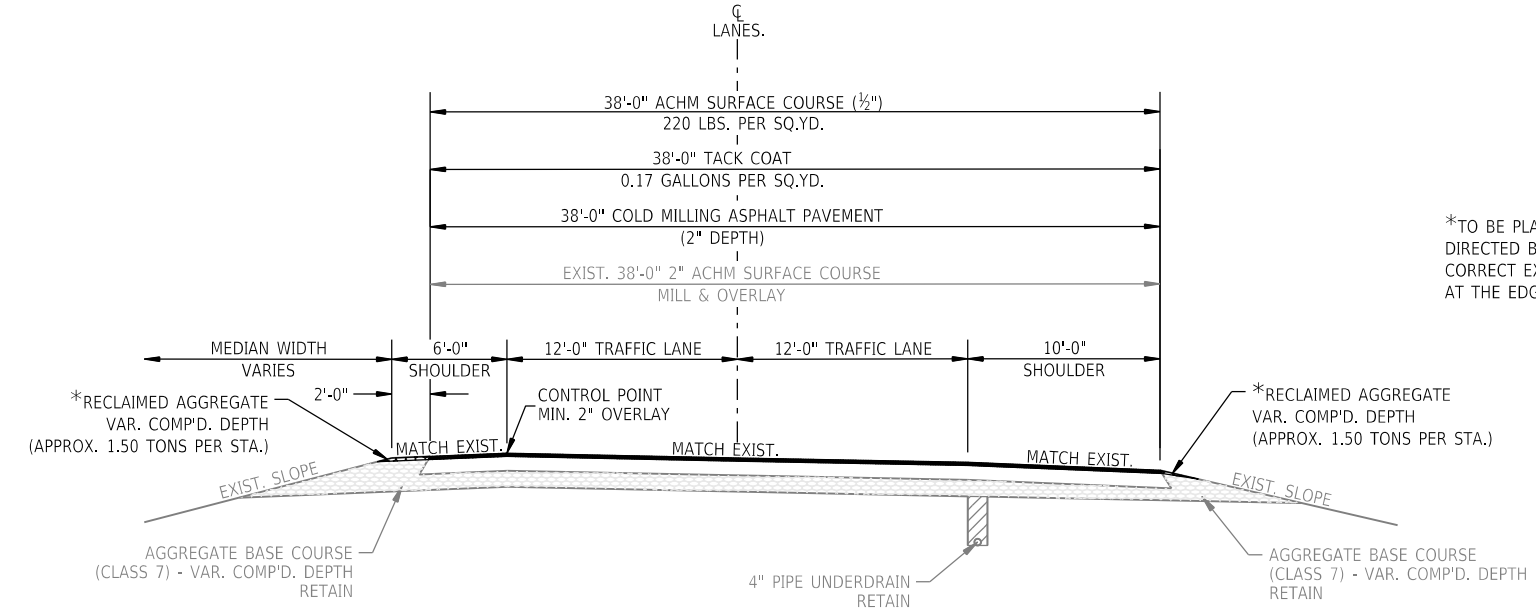
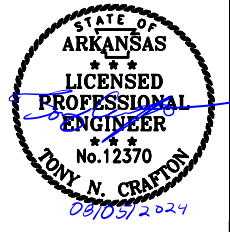

*TO BE PLACED IF AND WHERE DIRECTED BY THE ENGINEER TO CORRECT EXISTING DROP OFFS AT THE EDGE OF THE SHOULDER

I-40 - MILL & OVERLAY
SHOWN IN DIRECTION OF TRAVEL

WESTBOUND MAIN LANES		EASTBOUND MAIN LANES	
LOG MILE 209.555 TO	LOG MILE 211.605	LOG MILE 209.555 TO	LOG MILE 211.605
LOG MILE 211.644 TO	LOG MILE 215.985	LOG MILE 211.644 TO	LOG MILE 215.984
LOG MILE 216.047 TO	LOG MILE 217.761	LOG MILE 216.046 TO	LOG MILE 217.754
LOG MILE 217.785 TO	LOG MILE 219.888	LOG MILE 217.778 TO	LOG MILE 219.888
LOG MILE 219.926 TO	LOG MILE 226.184	LOG MILE 219.926 TO	LOG MILE 226.184
LOG MILE 226.221 TO	LOG MILE 233.965	LOG MILE 226.221 TO	LOG MILE 233.965
LOG MILE 234.129 TO	LOG MILE 237.729	LOG MILE 234.129 TO	LOG MILE 237.749
LOG MILE 237.759 TO	LOG MILE 239.417	LOG MILE 237.779 TO	LOG MILE 239.438
LOG MILE 239.448 TO	LOG MILE 239.749	LOG MILE 239.469 TO	LOG MILE 239.749

NOTE:
1. LOGITUDINAL JOINTS SHALL BE AT THE LANE LINES.

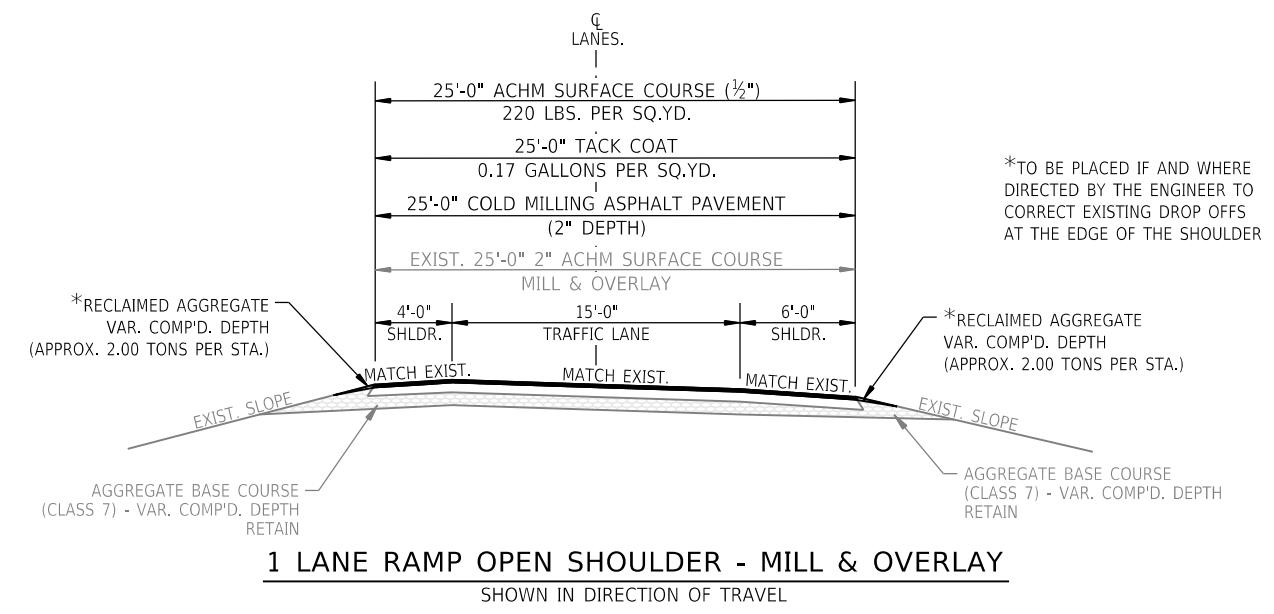

1 LANE RAMP OPEN SHOULDER - MILL & OVERLAY
SHOWN IN DIRECTION OF TRAVEL

WESTBOUND RAMPS		EASTBOUND RAMPS	
HWY. 49 - EXIT	LOG MILE 0.000 TO LOG MILE 0.181	HWY. 49 - EXIT	LOG MILE 0.004 TO LOG MILE 0.227
HWY. 49 - ENT.	LOG MILE 0.100 TO LOG MILE 0.232	HWY. 49 - ENT.	LOG MILE 0.073 TO LOG MILE 0.214
HWY. 78 - EXIT	LOG MILE 0.007 TO LOG MILE 0.266	HWY. 78 - EXIT	LOG MILE 0.013 TO LOG MILE 0.272
HWY. 78 - ENT.	LOG MILE 0.001 TO LOG MILE 0.205	HWY. 78 - ENT.	LOG MILE 0.003 TO LOG MILE 0.212
HWY. 261 - EXIT	LOG MILE 0.022 TO LOG MILE 0.180	HWY. 261 - EXIT	LOG MILE 0.000 TO LOG MILE 0.264
HWY. 261 - EXIT	LOG MILE 0.249 TO LOG MILE 0.297	HWY. 261 - ENT.	LOG MILE 0.002 TO LOG MILE 0.185
HWY. 261 - ENT.	LOG MILE 0.003 TO LOG MILE 0.048	REST AREA - EXIT	LOG MILE 0.028 TO LOG MILE 0.227
HWY. 261 - ENT.	LOG MILE 0.107 TO LOG MILE 0.220	REST AREA ROAD -	LOG MILE 0.019 TO LOG MILE 0.117
HWY. 1 - EXIT	LOG MILE 0.018 TO LOG MILE 0.333	REST AREA ROAD -	LOG MILE 0.337 TO LOG MILE 0.393
HWY. 1 - ENT.	LOG MILE 0.006 TO LOG MILE 0.342	REST AREA - ENT.	LOG MILE 0.000 TO LOG MILE 0.135
		HWY. 1 - EXIT	LOG MILE 0.010 TO LOG MILE 0.293
		HWY. 1 - ENT.	LOG MILE 0.009 TO LOG MILE 0.340

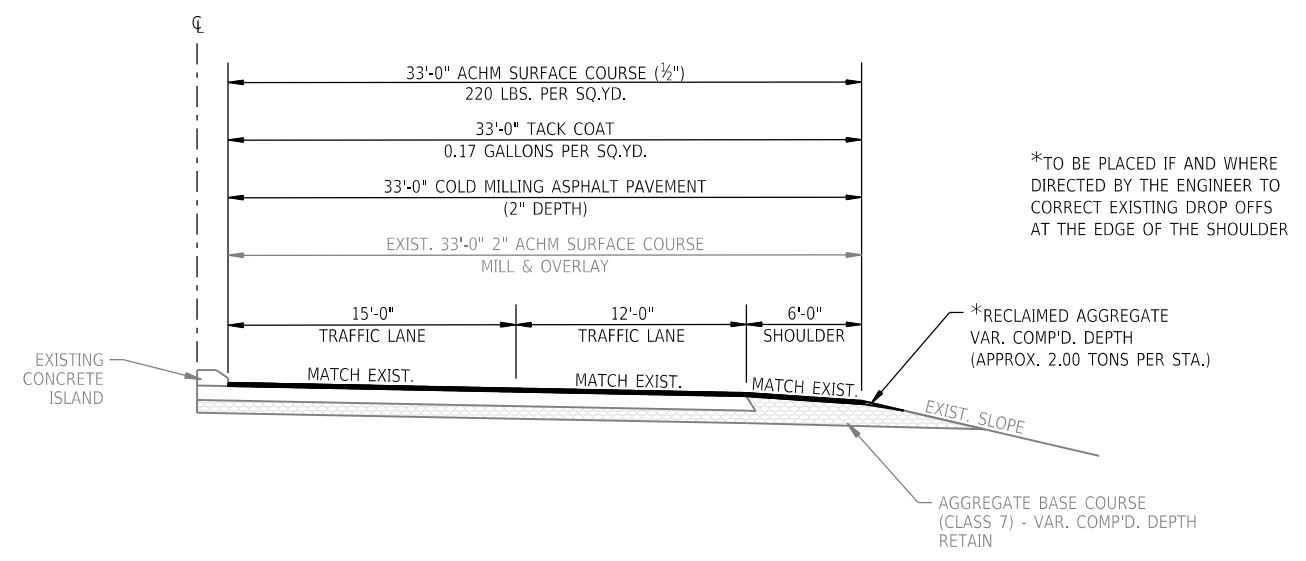

2 LANE RAMP WITH ISLAND - MILL & OVERLAY
SHOWN IN DIRECTION OF TRAVEL

EASTBOUND RAMP
HWY. 49 - EXIT LOG MILE 0.227 TO LOG MILE 0.297

DATE REVISED	DATE REVISED	FED. RD. DIST. NO.	STATE	JOB NO.	SHEET NO.	TOTAL SHEETS
		6	ARK.	110747	6	30
TYPICAL SECTIONS OF IMPROVEMENT						

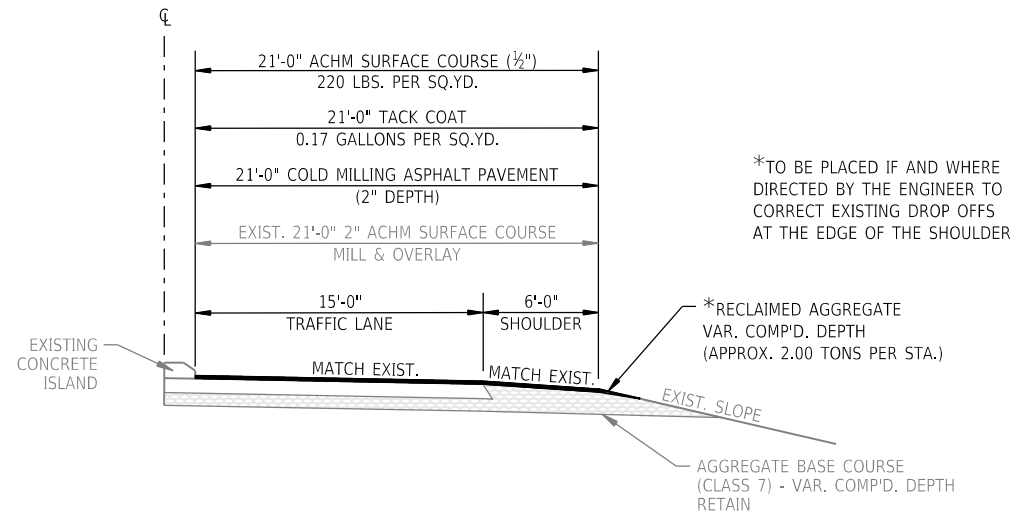

1 LANE RAMP WITH ISLAND - MILL & OVERLAY

SHOWN IN DIRECTION OF TRAVEL

WESTBOUND RAMPS

HWY. 49 - ENT. LOG MILE 0.006 TO LOG MILE 0.100
 HWY. 49 - EXIT LOG MILE 0.181 TO LOG MILE 0.297

EASTBOUND RAMPS

HWY. 49 - ENT. LOG MILE 0.005 TO LOG MILE 0.073

NOTE:
 1. LOGITUDINAL JOINTS SHALL BE AT THE LANE LINES.

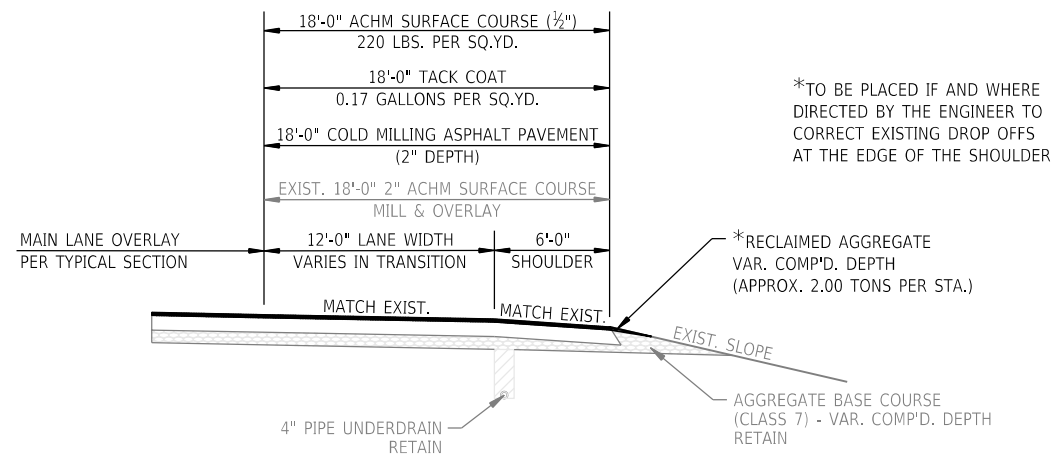

ACCELERATION/DECELERATION LANES - MILL & OVERLAY

SHOWN IN DIRECTION OF TRAVEL

WESTBOUND AUXILIARY LANES

LOG MILE 215.511 TO LOG MILE 215.695
 LOG MILE 220.610 TO LOG MILE 220.810
 LOG MILE 232.810 TO LOG MILE 232.992
 LOG MILE 238.625 TO LOG MILE 238.824

EASTBOUND AUXILIARY LANES

LOG MILE 215.624 TO LOG MILE 215.815
 LOG MILE 221.098 TO LOG MILE 221.284
 LOG MILE 233.304 TO LOG MILE 233.475
 LOG MILE 235.918 TO LOG MILE 236.075
 LOG MILE 239.165 TO LOG MILE 239.353

DATE REVISED	DATE REVISED	FED. RD. DIST. NO.	STATE	JOB NO.	SHEET NO.	TOTAL SHEETS
		6	ARK.	110747	7	30
TYPICAL SECTIONS OF IMPROVEMENT						

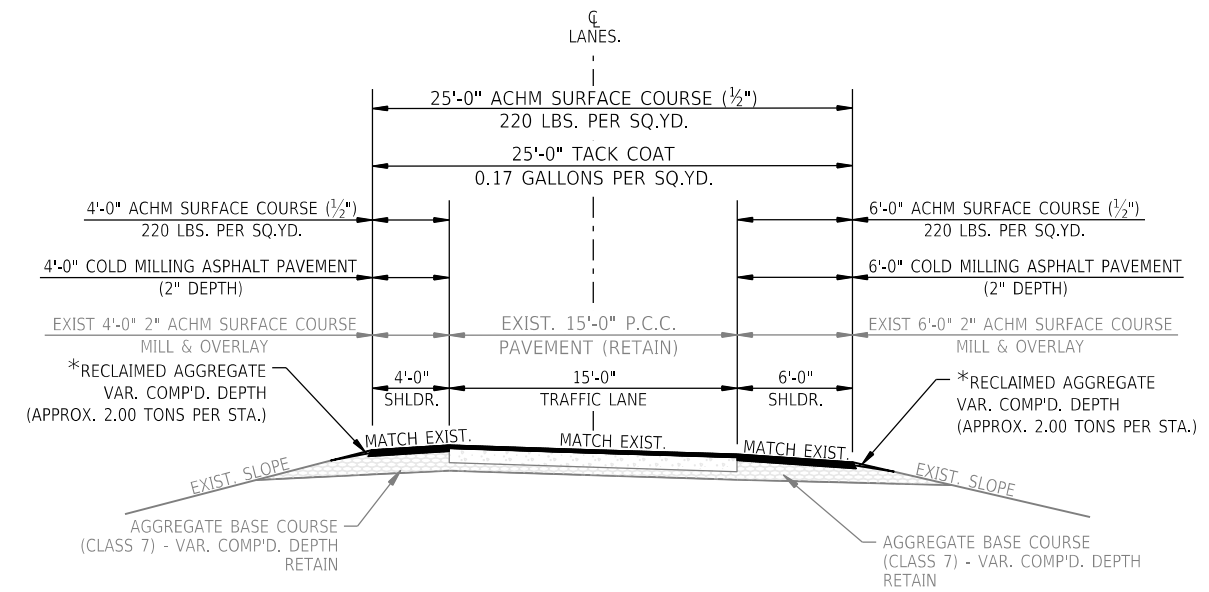

*TO BE PLACED IF AND WHERE DIRECTED BY THE ENGINEER TO CORRECT EXISTING DROP OFFS AT THE EDGE OF THE SHOULDER

1 LANE RAMP OPEN SHOULDER - OVERLAY

SHOWN IN DIRECTION OF TRAVEL
 WESTBOUND RAMP
 HWY. 261 - ENT. LOG MILE 0.048 TO LOG MILE 0.107
 HWY. 261 - EXIT LOG MILE 0.180 TO LOG MILE 0.249

NOTE:
 1. LONGITUDINAL JOINTS SHALL BE AT THE LANE LINES.

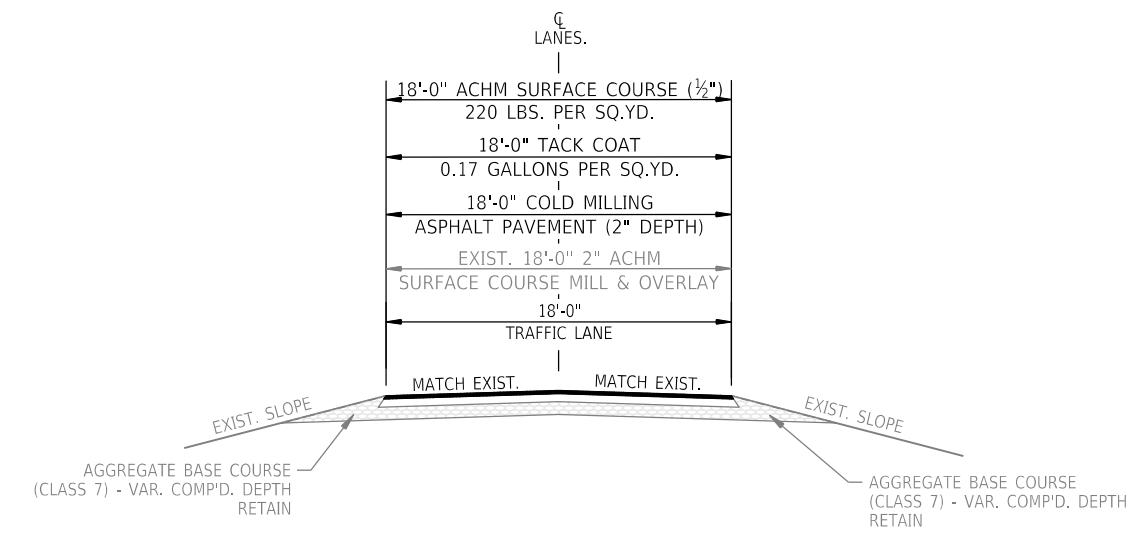

REST AREA - MILL & OVERLAY

SHOWN IN DIRECTION OF TRAVEL
 EASTBOUND REST AREA
 LOG MILE 0.117 TO LOG MILE 0.337

DATE REVISED	DATE REVISED	FED. RD. DIST. NO.	STATE	JOB NO.	SHEET NO.	TOTAL SHEETS
		6	ARK.	110747	8	30
SPECIAL DETAILS						

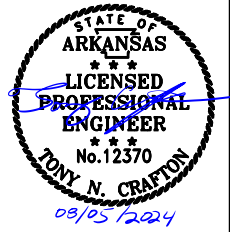

Job 110747
 Start Date Mo Year
 Est Completion Mo Year
IDRIVE
ARKANSAS.COM

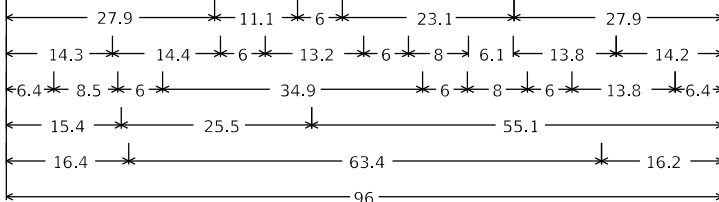

6.0" Radius, 1.3" Border, Black on Orange;
 *Job XXXXXX" C 2K; "Start Date Mo Year" C 2K;
 *Est Completion Mo Year" C 2K; "IDRIVE" " Arial;
 * ARKANSAS.COM " Arial;

CONSTRUCTION PROJECT INFORMATION SIGN

YELLOW BKG
BLACK LEGEND

WHITE BKG
BLACK LEGEND

ORANGE BKG
BLACK LEGEND

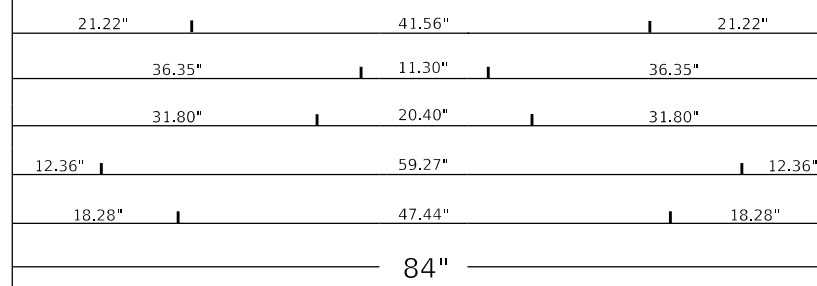
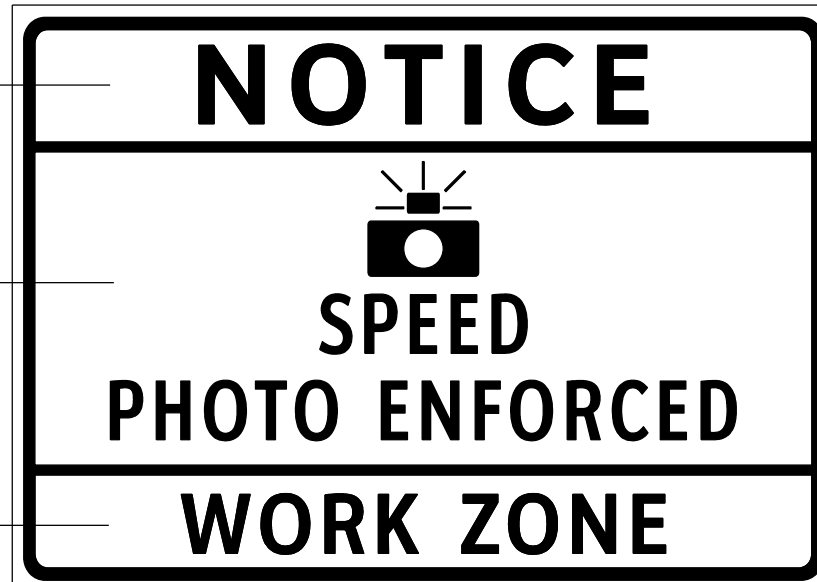

WZ-1 (INTERSTATE) SIGN

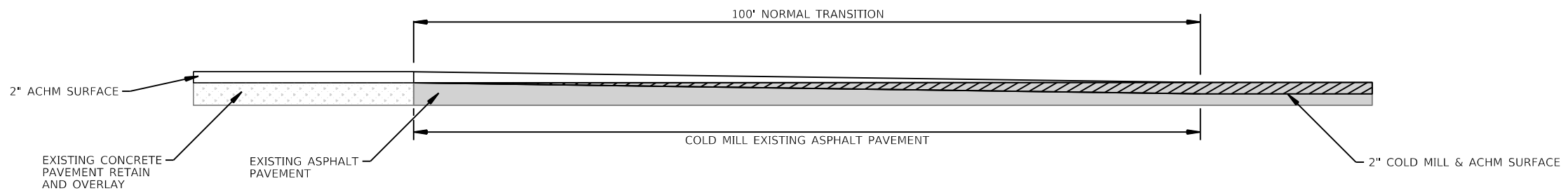
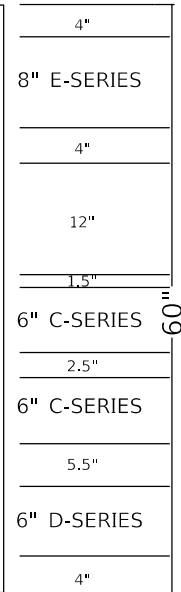

DETAIL FOR PAVEMENT TRANSITION

DATE REVISED	DATE REVISED	FED. RD. DIST. NO.	STATE	JOB NO.	SHEET NO.	TOTAL SHEETS
		6	ARK.	110747	9	30
SPECIAL DETAILS						

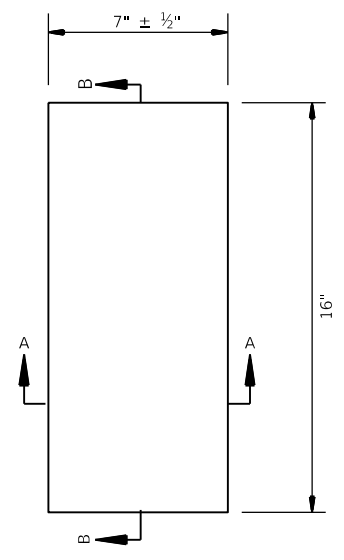
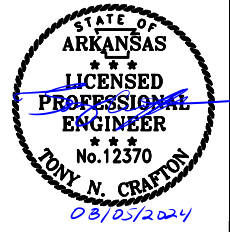

PLAN

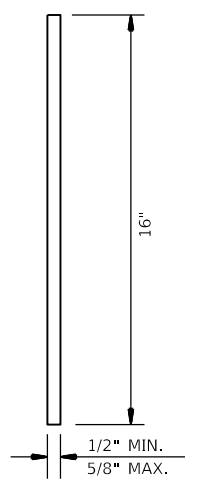

SECTION B-B

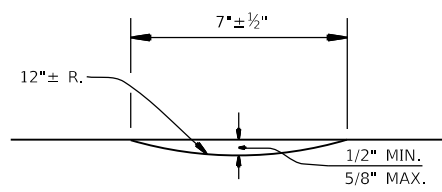

SECTION A-A

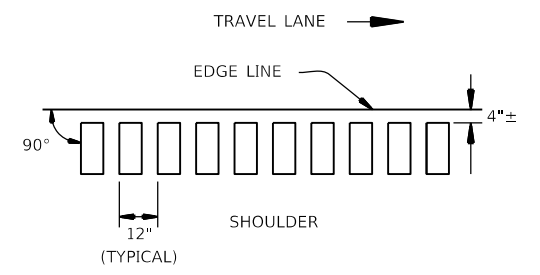

LOCATION PLAN OF RUMBLE STRIPS
LEFT OR RIGHT SHOULDER

DETAILS OF RUMBLE STRIPS

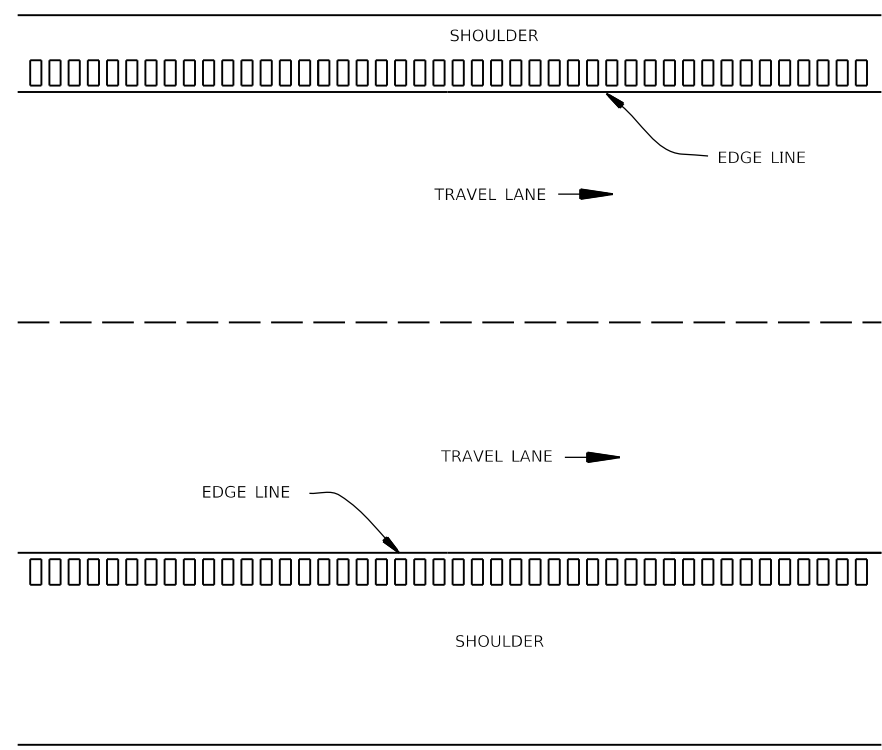

PLAN VIEW

NOTES:

- ALIGNMENT OF RUMBLE STRIPS SHALL GENERALLY BE STRAIGHT AND OFFSET APPROXIMATELY 4" FROM THE OUTER EDGE OF THE EDGE LINE. THIS OFFSET MAY BE ADJUSTED TO ACCOMMODATE VARIATIONS IN THE EDGE LINE.
- THE 1/2" DEPTH SHALL GENERALLY APPLY FOR THE ENTIRE 16" LENGTH. SOME VARIATION TO SUIT SHOULDER SLOPE BREAKS MAY BE NECESSARY.
- RUMBLE STRIPS SHALL NOT BE INSTALLED ON BRIDGE DECKS, APPROACH SLABS, OR ACROSS TRANSVERSE JOINTS OF CONCRETE SHOULDERS.

DATE REVISED	DATE REVISED	FED. RD. DIST. NO.	STATE	JOB NO.	SHEET NO.	TOTAL SHEETS
		6	ARK.	110747	11	30
SPECIAL DETAILS						

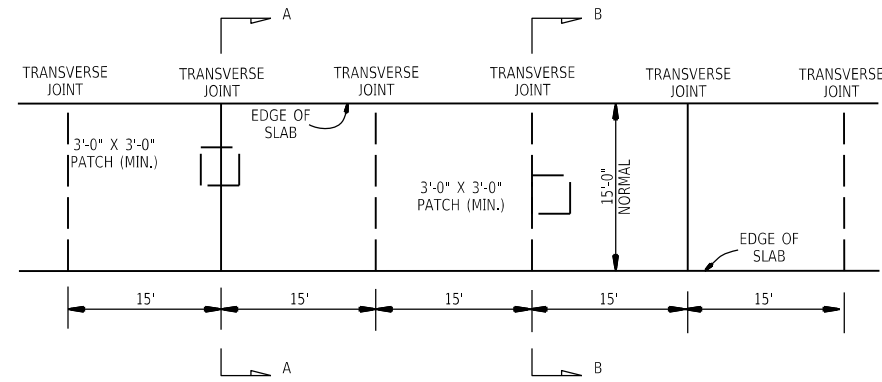
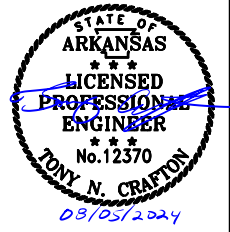

PLAN VIEW OF SPALL REPAIR OF P.C.C. PAVEMENT

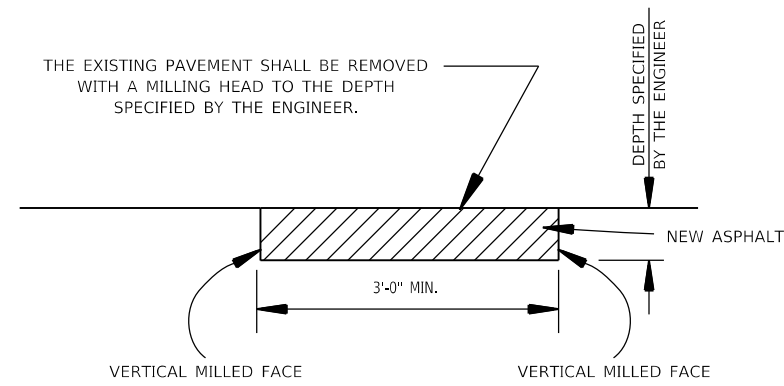

DETAIL OF SPALL REPAIR SECTION A-A

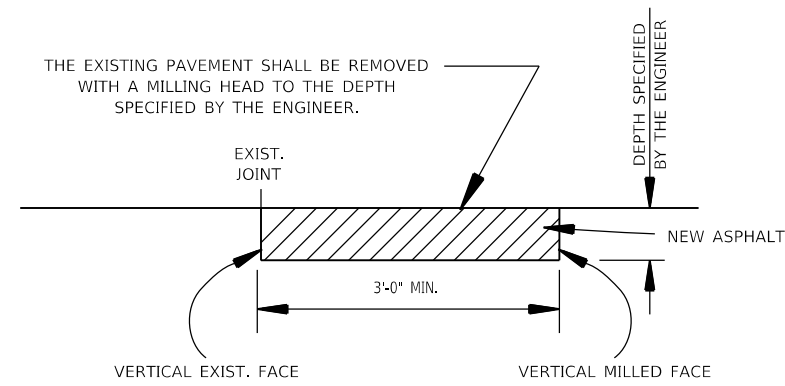

DETAIL OF SPALL REPAIR SECTION B-B

DETAILS OF SPALL REPAIR OF P.C.C. PAVEMENT

NOTE: THE EXACT SIZE AND LOCATION OF AREA TO BE REPAIRED SHALL BE DETERMINED BY THE ENGINEER.

DATE REVISED	DATE REVISED	FED. RD. DIST. NO.	STATE	JOB NO.	SHEET NO.	TOTAL SHEETS
		6	ARK.	110747	12	30
MAINTENANCE OF TRAFFIC DETAILS						



SEQUENCE OF CONSTRUCTION

STAGE 1:
 INSTALL ADVANCE WARNING SIGNS AND DEVICES FOR THE LEFT (INSIDE) LANE CLOSURE AS SHOWN IN THE MAINTENANCE OF TRAFFIC DETAILS.

MILL AND OVERLAY THE LEFT (INSIDE) LANE AND SHOULDER.

PERFORM THE JOINT REPAIR ON THE LEFT (INSIDE) LANE AND SHOULDER FOR BRIDGE NO. B3724 & A3731.

SHIFT ADVANCE WARNING SIGNS AS CONSTRUCTION PROGRESSES.

STAGE 2:
 INSTALL ADVANCE WARNING SIGNS AND DEVICES FOR THE RIGHT (OUTSIDE) LANE CLOSURE AS SHOWN IN THE MAINTENANCE OF TRAFFIC DETAILS.

MILL AND OVERLAY THE RIGHT (OUTSIDE) LANE AND SHOULDER.

PERFORM THE JOINT REPAIR ON THE RIGHT (OUTSIDE) LANE AND SHOULDER FOR BRIDGE NO. B3724 & A3731.

SHIFT ADVANCE WARNING SIGNS AS CONSTRUCTION PROGRESSES.

STAGE 3:
 INSTALL ADVANCE WARNING SIGNS AND DEVICES FOR THE RIGHT (OUTSIDE) LANE CLOSURE AS SHOWN IN THE MAINTENANCE OF TRAFFIC DETAILS.

MILL AND OVERLAY THE ACCELERATION & DECELERATION LANES.

SHIFT ADVANCE WARNING SIGNS AS CONSTRUCTION PROGRESSES.

SEQUENCE OF CONSTRUCTION
 MAINTENANCE OF TRAFFIC DETAILS

DATE REVISED	DATE REVISED	FED. RD. DIST. NO.	STATE	JOB NO.	SHEET NO.	TOTAL SHEETS
		6	ARK.	110747	13	30
MAINTENANCE OF TRAFFIC DETAILS						

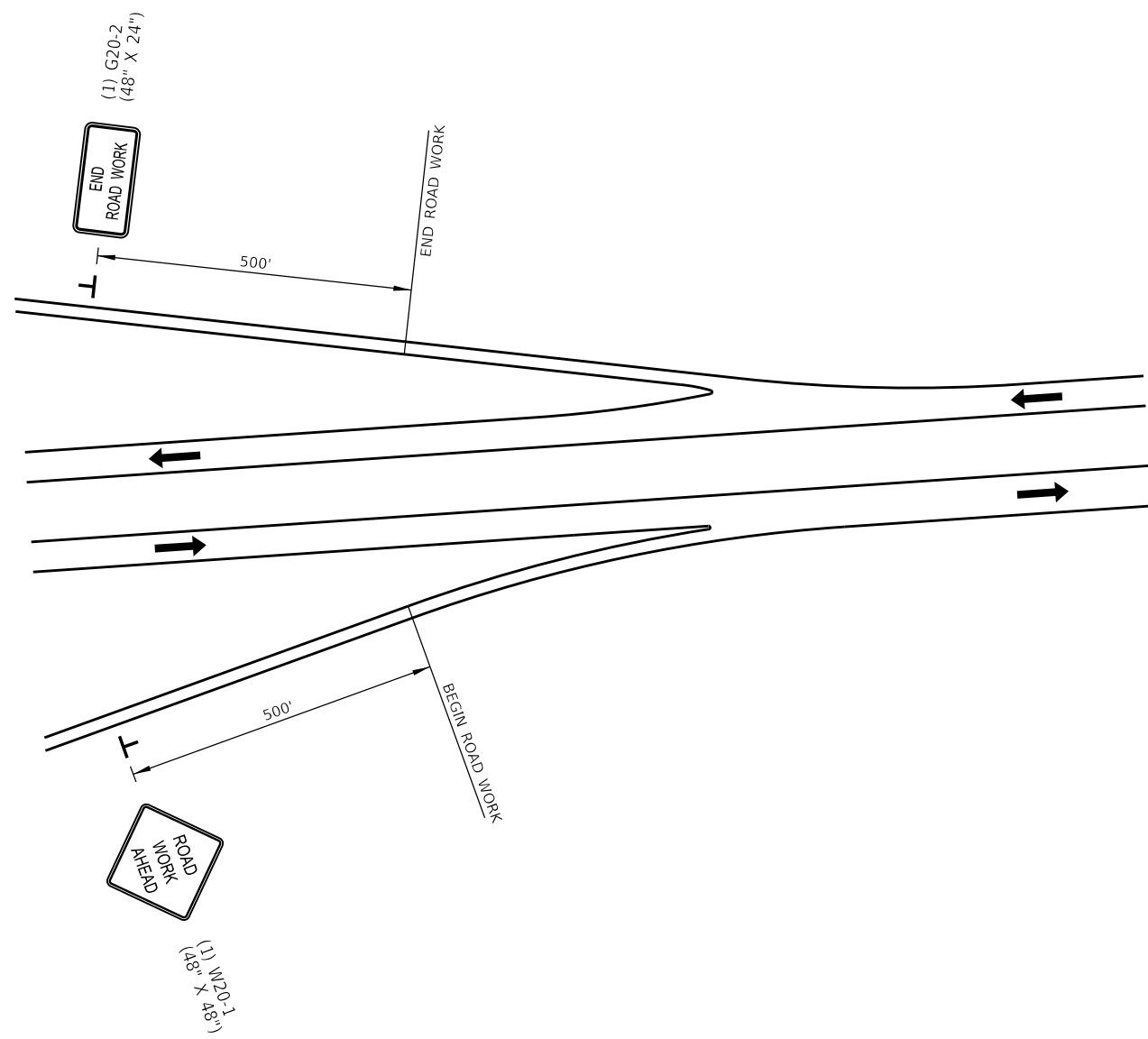

NOTE:
SEE STANDARD DRAWING TC-6 FOR ADVANCE WARNING SIGNS TO BE PLACED ON I-40.

DETAIL OF ENTRANCE AND EXIT RAMP

- | | |
|---|---|
| <p>WESTBOUND LANES</p> <ul style="list-style-type: none"> EXIT 216: ENTRANCE AND EXIT RAMP EXIT 221: ENTRANCE AND EXIT RAMP EXIT 233: ENTRANCE AND EXIT RAMP EXIT 239: ENTRANCE AND EXIT RAMP EXIT 241A: EXIT RAMP | <p>EASTBOUND LANES</p> <ul style="list-style-type: none"> EXIT 216: ENTRANCE AND EXIT RAMP EXIT 221: ENTRANCE AND EXIT RAMP EXIT 233: ENTRANCE AND EXIT RAMP EXIT 239: ENTRANCE AND EXIT RAMP EXIT 241A: ENTRANCE AND EXIT RAMP EXIT 241B: ENTRANCE AND EXIT RAMP |
|---|---|

ADVANCE WARNING SIGNS
MAINTENANCE OF TRAFFIC DETAILS

DATE REVISED	DATE REVISED	FED. RD. DIST. NO.	STATE	JOB NO.	SHEET NO.	TOTAL SHEETS
		6	ARK.	110747	14	30
MAINTENANCE OF TRAFFIC DETAILS						

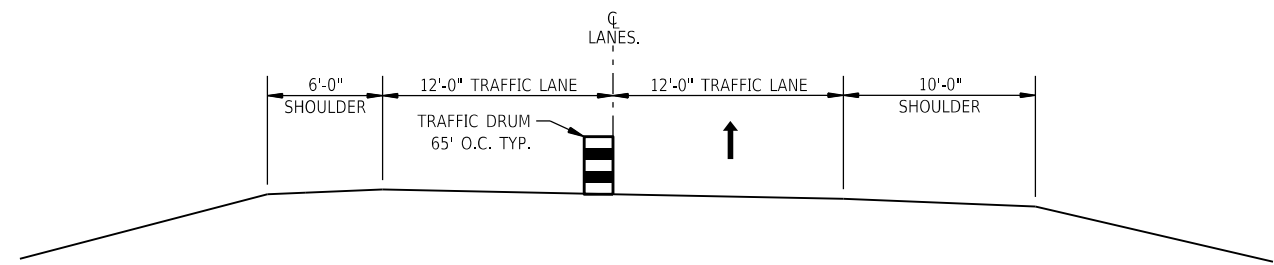
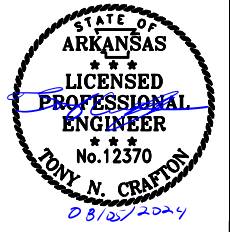

STAGE 1
 LOCATION OF TRAFFIC DRUMS FOR MAINTENANCE OF TRAFFIC
 LEFT (INSIDE) LANE CLOSED
 (SHOWN IN DIRECTION OF TRAFFIC)

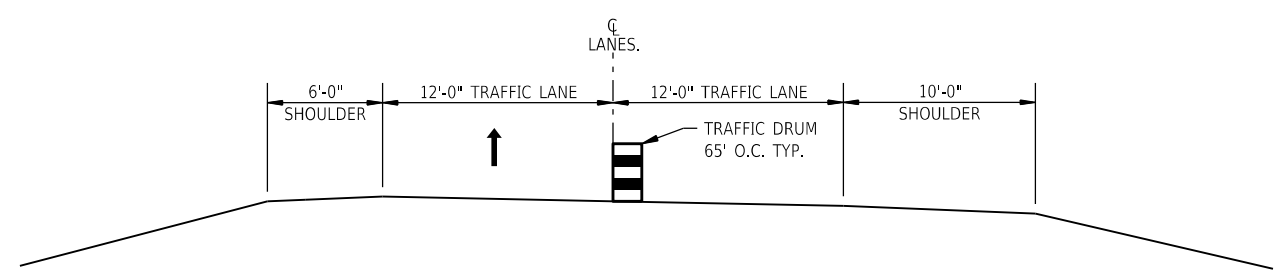

STAGE 2
 LOCATION OF TRAFFIC DRUMS FOR MAINTENANCE OF TRAFFIC
 RIGHT (OUTSIDE) LANE CLOSED
 (SHOWN IN DIRECTION OF TRAFFIC)

DETAIL OF MAIN LANE CLOSURE
 MAINTENANCE OF TRAFFIC DETAILS

DATE REVISED	DATE REVISED	FED. RD. DIST. NO.	STATE	JOB NO.	SHEET NO.	TOTAL SHEETS
		6	ARK.	110747	16	30
MAINTENANCE OF TRAFFIC DETAILS						

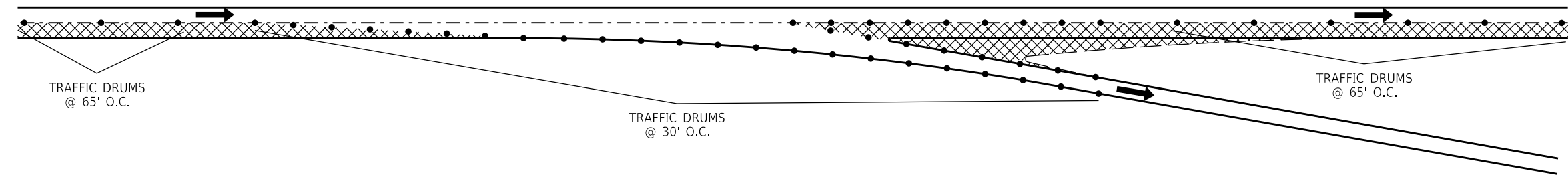
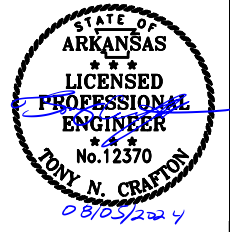

EXIT RAMP - TYPICAL TRAFFIC DRUM LAYOUT
OUTSIDE LANE CLOSURE

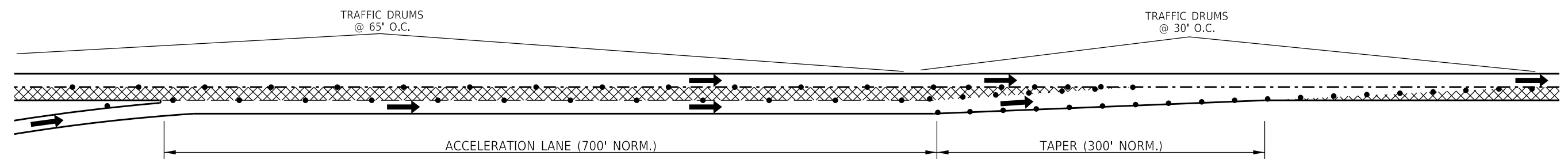

ENTRANCE RAMP - TYPICAL TRAFFIC DRUM LAYOUT
OUTSIDE LANE CLOSURE

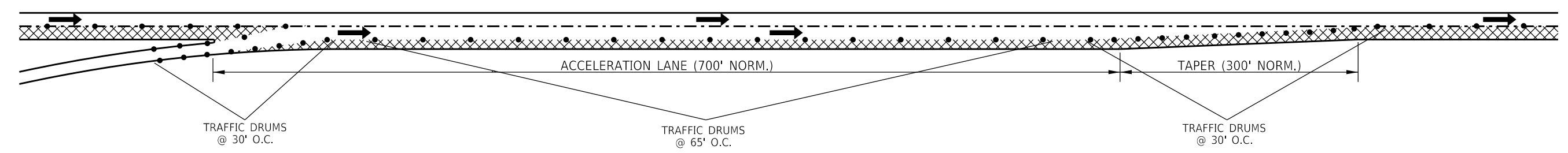

ENTRANCE RAMP - TYPICAL TRAFFIC DRUM LAYOUT
ACCELERATION LANE CLOSURE

DATE REVISED	DATE REVISED	FED. RD. DIST. NO.	STATE	JOB NO.	SHEET NO.	TOTAL SHEETS
		6	ARK.	110747	17	30
PERMANENT PAVEMENT MARKING DETAILS						



ASPHALT ROADWAY

SKIP LINE - ENHANCED THERMOPLASTIC PAVEMENT MARKING
 EDGE LINES - ENHANCED THERMOPLASTIC PAVEMENT MARKING
 REFER TO SPECIAL PROVISION - ENHANCED THERMOPLASTIC PAVEMENT MARKING

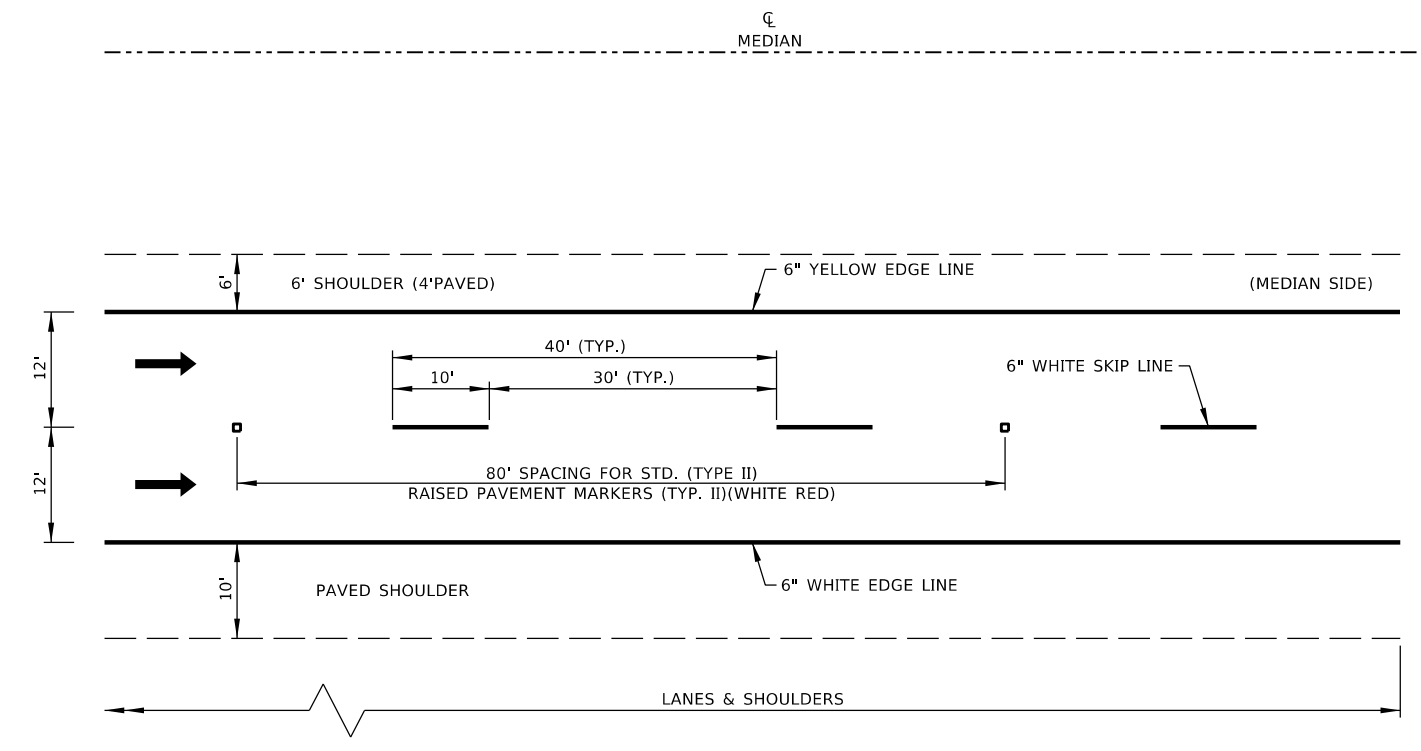

MAIN LANES
 PERMANENT PAVEMENT MARKING DETAILS

DATE REVISED	DATE REVISED	FED. RD. DIST. NO.	STATE	JOB NO.	SHEET NO.	TOTAL SHEETS
		6	ARK.	110747	18	30
PERMANENT PAVEMENT MARKING DETAILS						

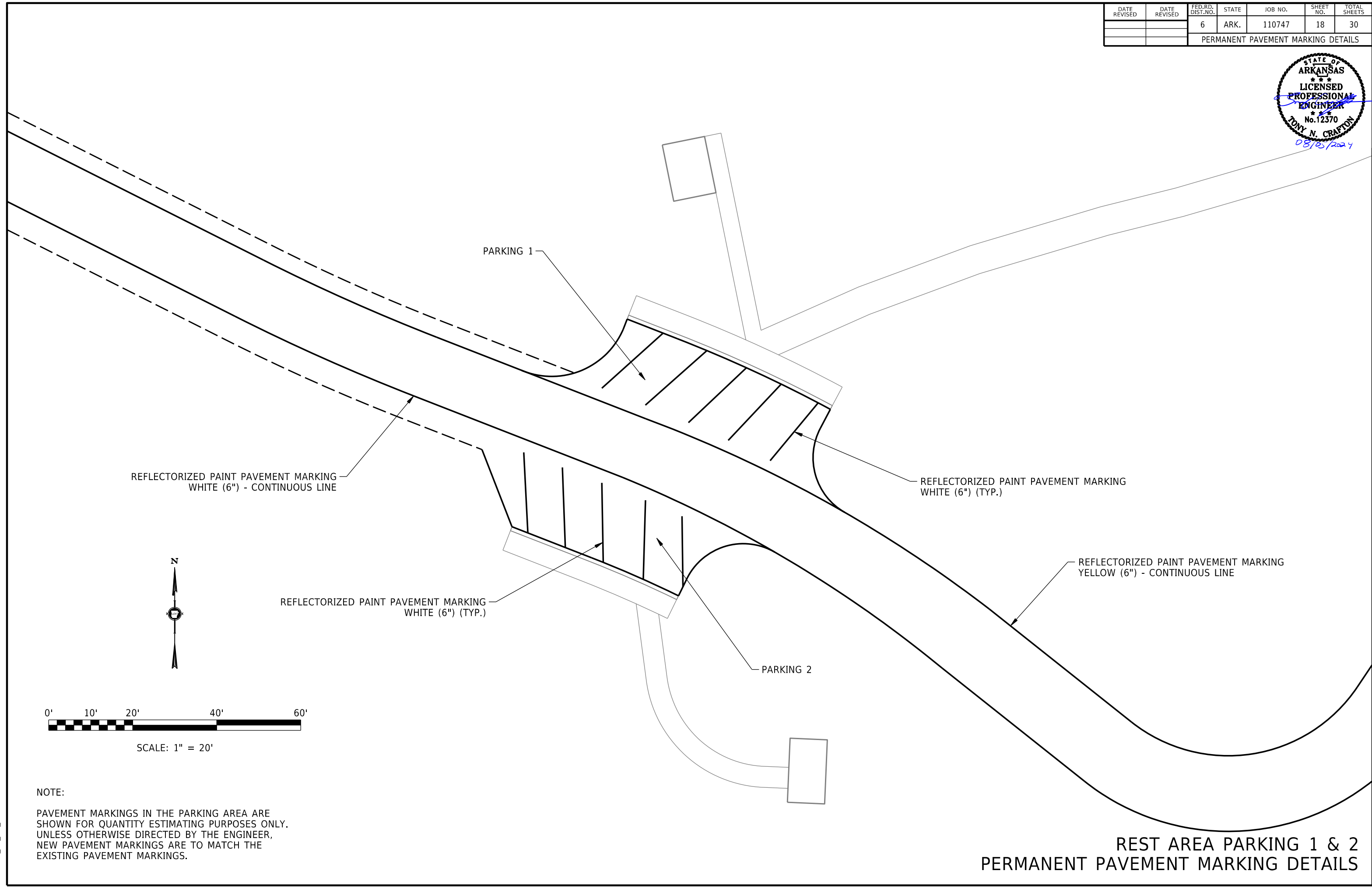
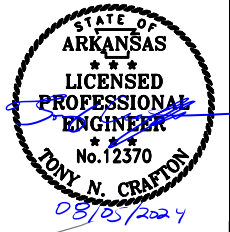

REFLECTORIZED PAINT PAVEMENT MARKING
WHITE (6") - CONTINUOUS LINE

REFLECTORIZED PAINT PAVEMENT MARKING
WHITE (6") (TYP.)

REFLECTORIZED PAINT PAVEMENT MARKING
YELLOW (6") - CONTINUOUS LINE

REFLECTORIZED PAINT PAVEMENT MARKING
WHITE (6") (TYP.)

PARKING 2

PARKING 1



SCALE: 1" = 20'

NOTE:
PAVEMENT MARKINGS IN THE PARKING AREA ARE SHOWN FOR QUANTITY ESTIMATING PURPOSES ONLY. UNLESS OTHERWISE DIRECTED BY THE ENGINEER, NEW PAVEMENT MARKINGS ARE TO MATCH THE EXISTING PAVEMENT MARKINGS.

REST AREA PARKING 1 & 2
PERMANENT PAVEMENT MARKING DETAILS

R110747_07_PM_002.DGN SAVED: 6/20/2024

DATE REVISED	DATE REVISED	FED. RD. DIST. NO.	STATE	JOB NO.	SHEET NO.	TOTAL SHEETS
		6	ARK.	110747	19	30
PERMANENT PAVEMENT MARKING DETAILS						

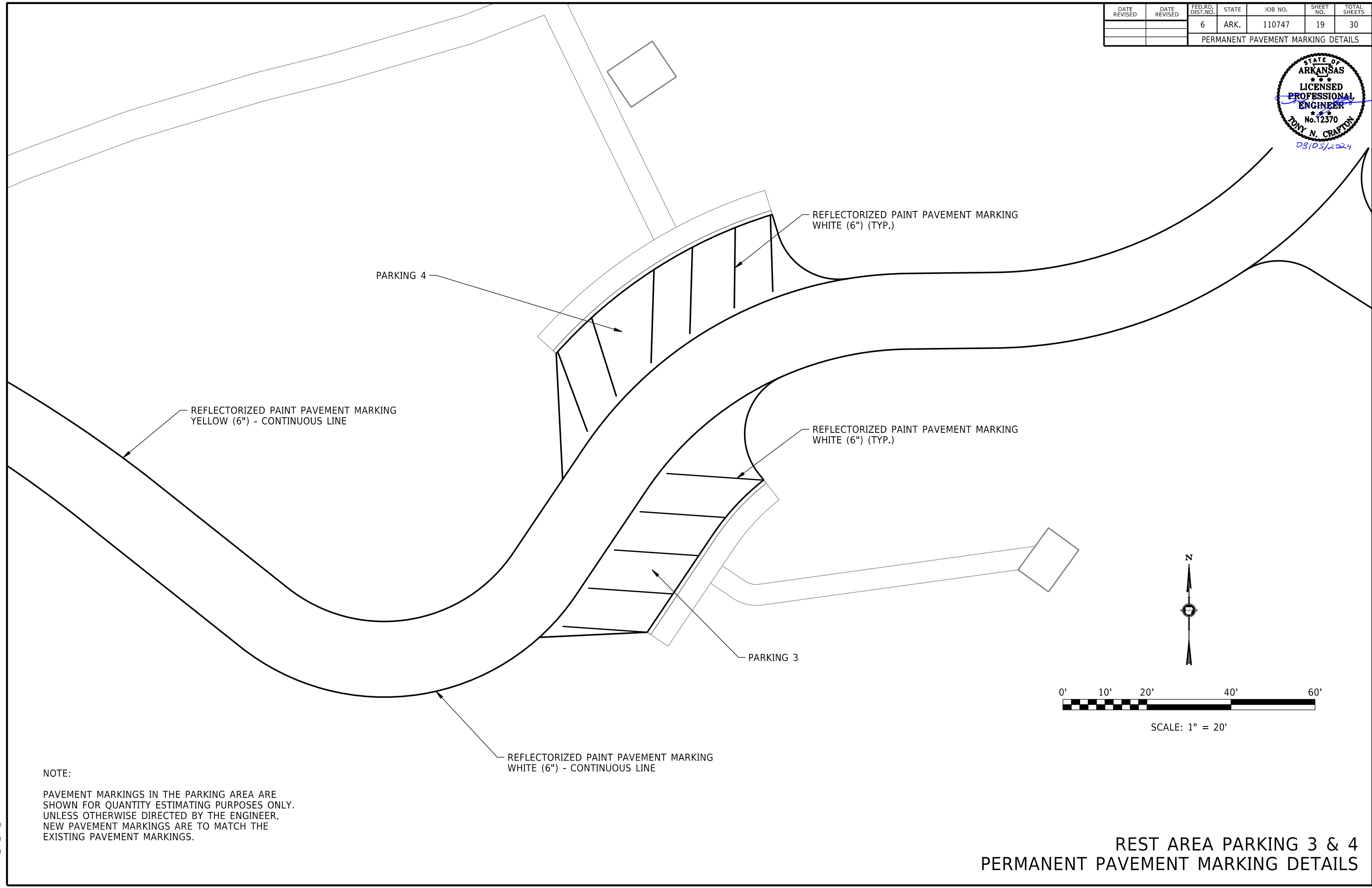
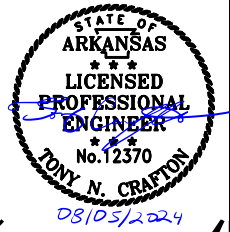

REFLECTORIZED PAINT PAVEMENT MARKING
WHITE (6") (TYP.)

PARKING 4

REFLECTORIZED PAINT PAVEMENT MARKING
YELLOW (6") - CONTINUOUS LINE

REFLECTORIZED PAINT PAVEMENT MARKING
WHITE (6") (TYP.)

PARKING 3

REFLECTORIZED PAINT PAVEMENT MARKING
WHITE (6") - CONTINUOUS LINE

NOTE:

PAVEMENT MARKINGS IN THE PARKING AREA ARE SHOWN FOR QUANTITY ESTIMATING PURPOSES ONLY. UNLESS OTHERWISE DIRECTED BY THE ENGINEER, NEW PAVEMENT MARKINGS ARE TO MATCH THE EXISTING PAVEMENT MARKINGS.



SCALE: 1" = 20'

REST AREA PARKING 3 & 4
PERMANENT PAVEMENT MARKING DETAILS

R110747_07_PM_003.DGN SAVED: 7/8/2024

DATE REVISED	DATE REVISED	FED. RD. DIST. NO.	STATE	JOB NO.	SHEET NO.	TOTAL SHEETS
		6	ARK.	110747	20	30
PERMANENT PAVEMENT MARKING DETAILS						

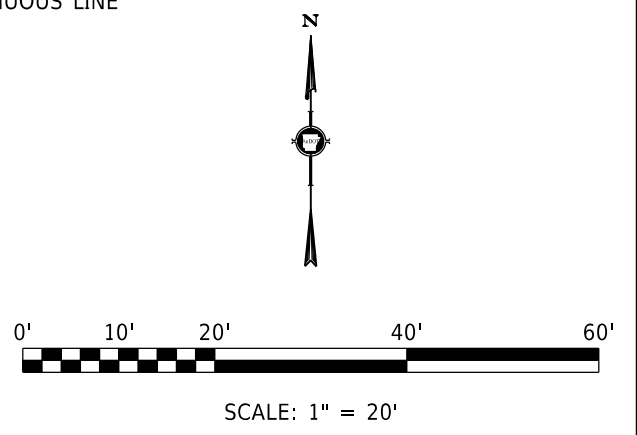
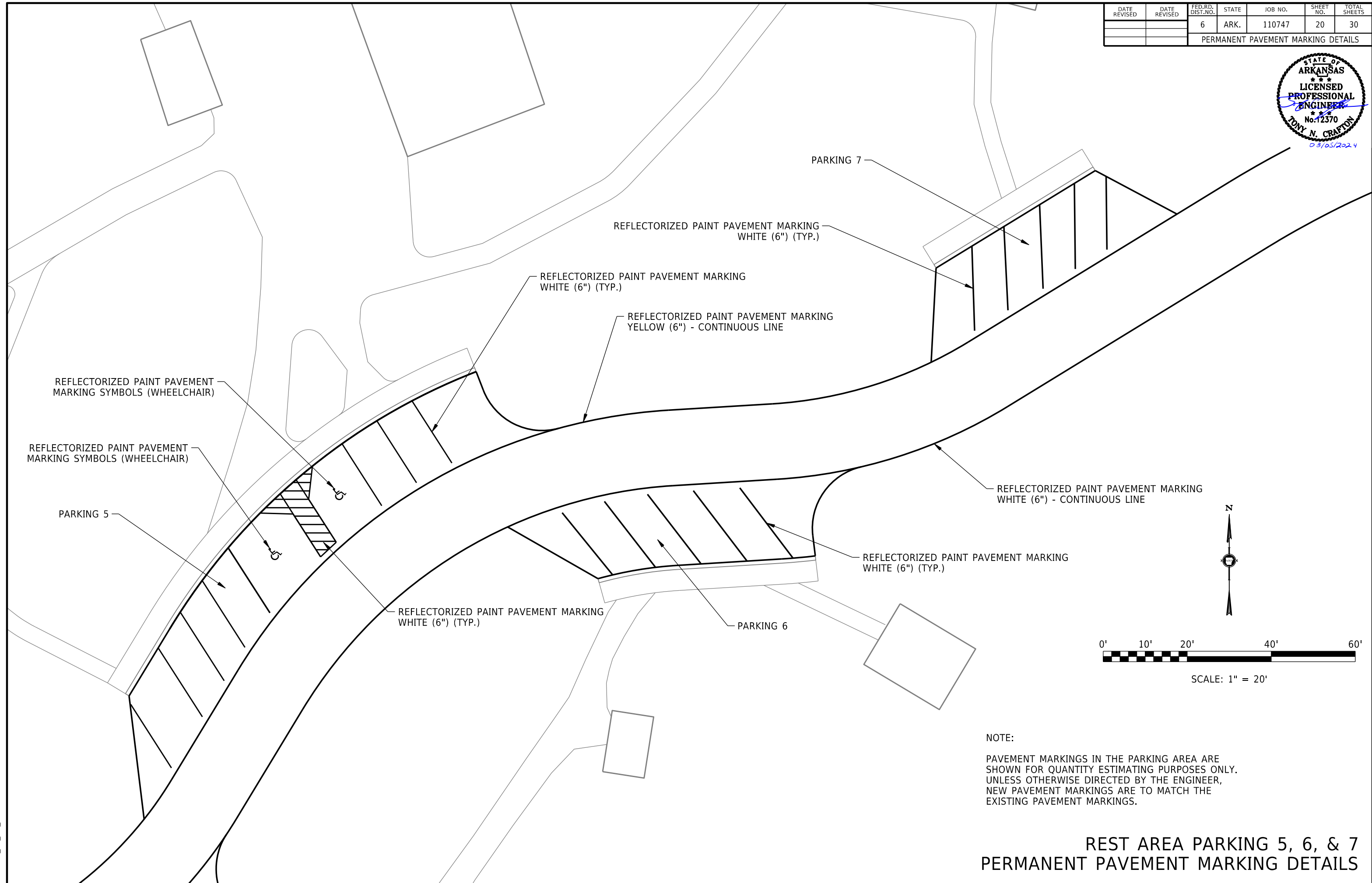
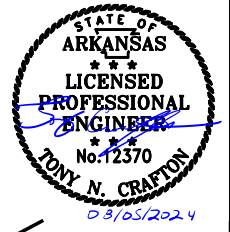

NOTE:
 PAVEMENT MARKINGS IN THE PARKING AREA ARE SHOWN FOR QUANTITY ESTIMATING PURPOSES ONLY. UNLESS OTHERWISE DIRECTED BY THE ENGINEER, NEW PAVEMENT MARKINGS ARE TO MATCH THE EXISTING PAVEMENT MARKINGS.

**REST AREA PARKING 5, 6, & 7
 PERMANENT PAVEMENT MARKING DETAILS**

R110747_07_PM_004.DGN SAVED: 6/27/2024

DATE REVISED	DATE REVISED	FED. RD. DIST. NO.	STATE	JOB NO.	SHEET NO.	TOTAL SHEETS
		6	ARK.	110747	21	30
PERMANENT PAVEMENT MARKING DETAILS						

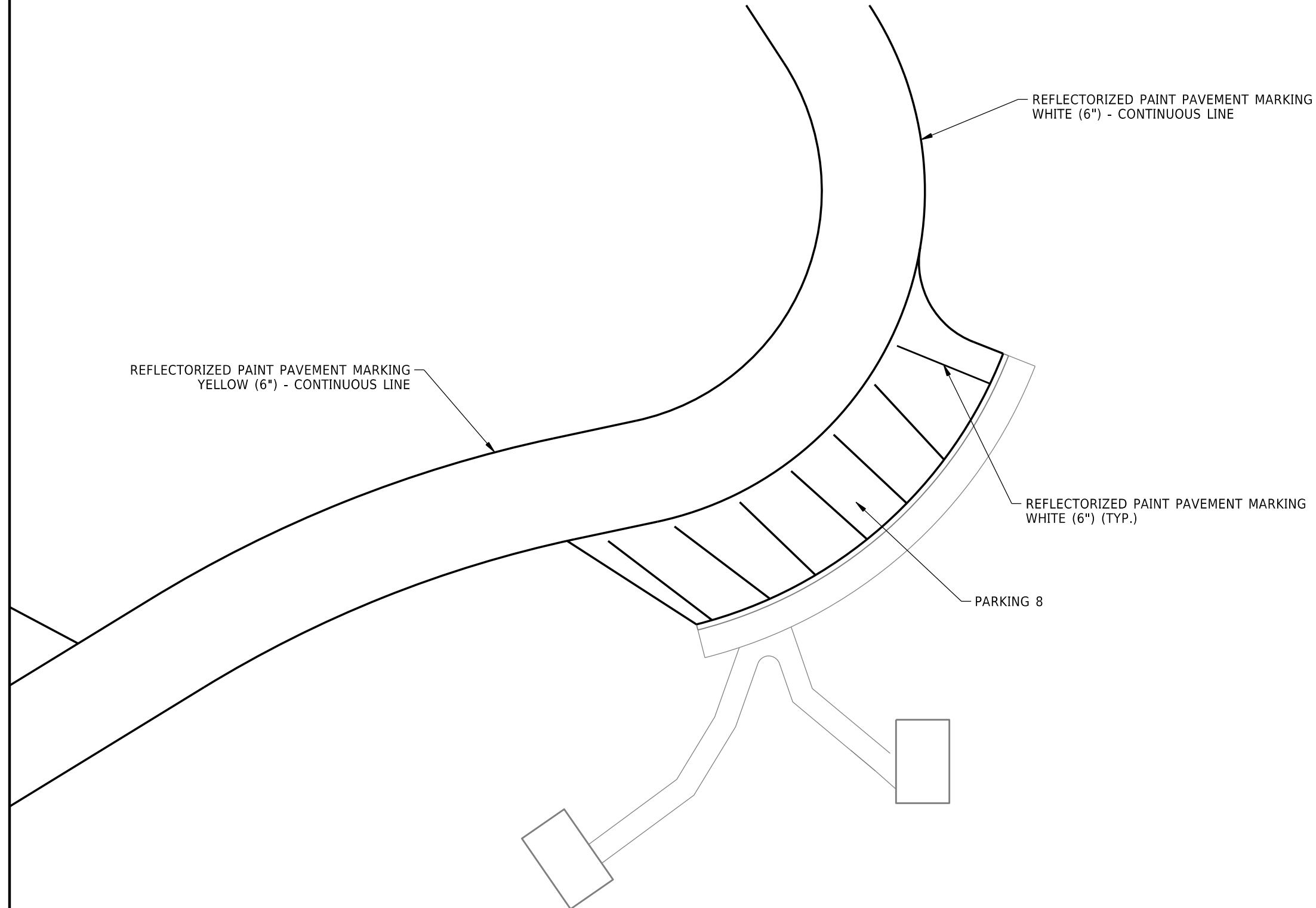

REFLECTORIZED PAINT PAVEMENT MARKING
YELLOW (6") - CONTINUOUS LINE

REFLECTORIZED PAINT PAVEMENT MARKING
WHITE (6") - CONTINUOUS LINE

REFLECTORIZED PAINT PAVEMENT MARKING
WHITE (6") (TYP.)

PARKING 8



SCALE: 1" = 20'

NOTE:

PAVEMENT MARKINGS IN THE PARKING AREA ARE SHOWN FOR QUANTITY ESTIMATING PURPOSES ONLY. UNLESS OTHERWISE DIRECTED BY THE ENGINEER, NEW PAVEMENT MARKINGS ARE TO MATCH THE EXISTING PAVEMENT MARKINGS.

REST AREA PARKING 8
PERMANENT PAVEMENT MARKING DETAILS

R110747_07_PM_005.DGN SAVED: 7/8/2024

DATE REVISED	DATE REVISED	FED. RD. DIST. NO.	STATE	JOB NO.	SHEET NO.	TOTAL SHEETS
		6	ARK.	110747	22	30
PERMANENT PAVEMENT MARKING DETAILS						

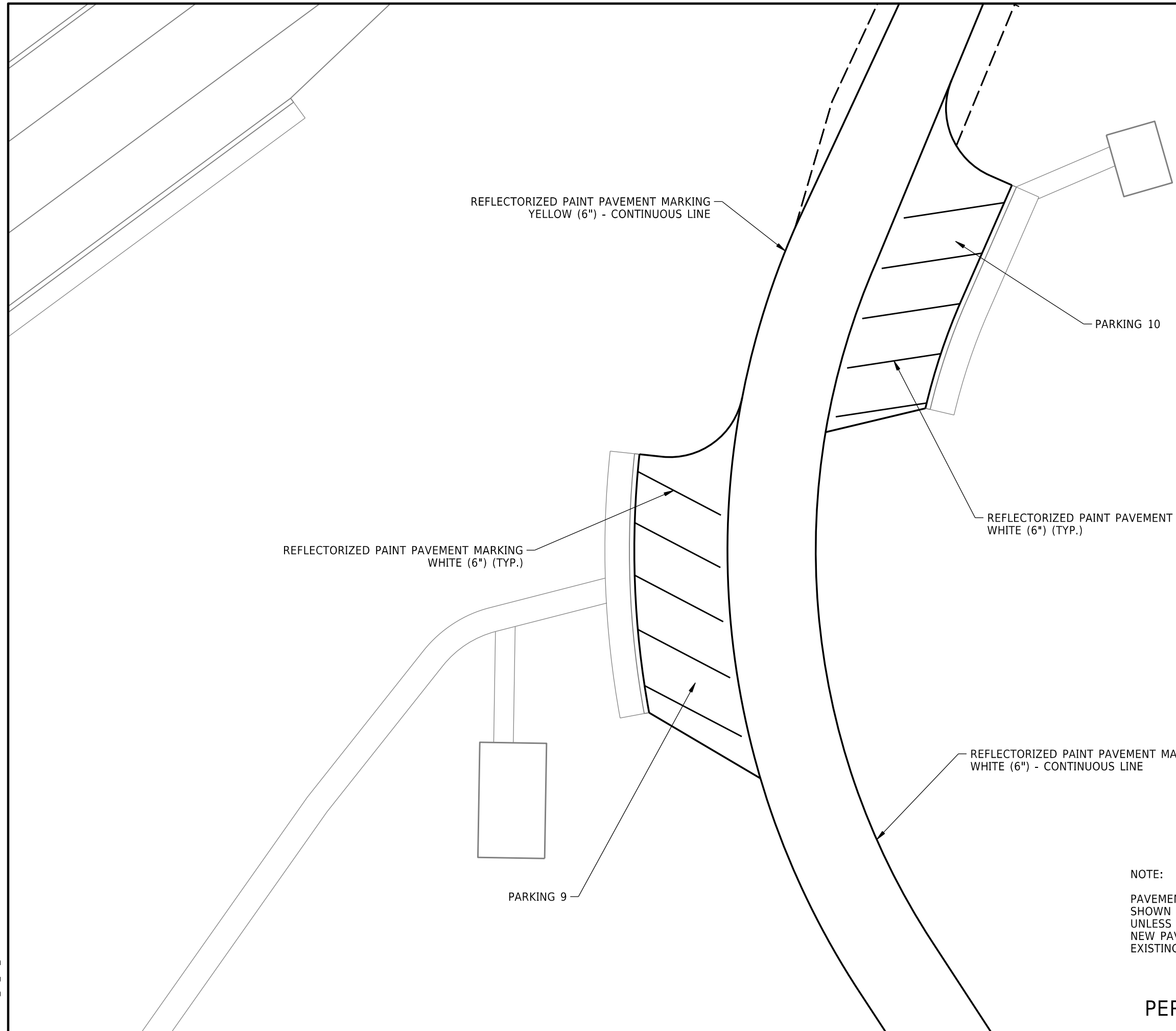

REFLECTORIZED PAINT PAVEMENT MARKING
YELLOW (6") - CONTINUOUS LINE

PARKING 10

REFLECTORIZED PAINT PAVEMENT MARKING
WHITE (6") (TYP.)

REFLECTORIZED PAINT PAVEMENT MARKING
WHITE (6") (TYP.)

REFLECTORIZED PAINT PAVEMENT MARKING
WHITE (6") - CONTINUOUS LINE

PARKING 9

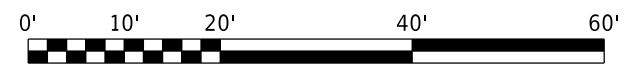

SCALE: 1" = 20'

NOTE:

PAVEMENT MARKINGS IN THE PARKING AREA ARE SHOWN FOR QUANTITY ESTIMATING PURPOSES ONLY. UNLESS OTHERWISE DIRECTED BY THE ENGINEER, NEW PAVEMENT MARKINGS ARE TO MATCH THE EXISTING PAVEMENT MARKINGS.

**REST AREA PARKING 9 & 10
PERMANENT PAVEMENT MARKING DETAILS**

R110747_07_PM_006.DGN SAVED: 6/19/2024

DATE REVISED	DATE REVISED	FED. RD. DIST. NO.	STATE	JOB NO.	SHEET NO.	TOTAL SHEETS
		6	ARK.	110747	23	30
QUANTITIES						



ADVANCE WARNING SIGNS AND DEVICES

SIGN NUMBER	DESCRIPTION	SIGN SIZE	STAGE 1	STAGE 2	STAGE 3	MAXIMUM NUMBER REQUIRED	TOTAL SIGNS REQUIRED		* CONSTRUCTION PROJECT INFORMATION SIGN UPDATE	TRAFFIC DRUMS	* ADVANCE WARNING ARROW PANEL	* PORTABLE CHANGEABLE MESSAGE SIGN	MOBILE SPEED NOTIFICATION SYSTEM (SPECIAL)					
			LIN. FT. - EACH				NO.	SQ. FT.						EACH	EACH	DAY	WEEK	EACH
W20-1	ROAD WORK 1 MILE	48"x48"	4	4	4	4	4	64.0										
W20-1	ROAD WORK 1/2 MILE	48"x48"	4	4	4	4	4	64.0										
W20-1	ROAD WORK 1500 FT.	48"x48"	4	4	4	4	4	64.0										
W20-1	ROAD WORK AHEAD	48"x48"	15	15	15	15	15	240.0										
W20-5	RIGHT LANE CLOSED 1 MILE	48"x48"	4	4	4	4	4	64.0										
W20-5	RIGHT LANE CLOSED 1/2 MILE	48"x48"	4	4	4	4	4	64.0										
W20-5	RIGHT LANE CLOSED 1500 FT.	48"x48"	4	4	4	4	4	64.0										
G20-2	END ROAD WORK	48"x24"	15	15	15	15	15	120.0										
G20-1	ROAD WORK NEXT 31 MILES	60"x24"	2	2	2	2	2	20.0										
G20-5aP	WORK ZONE	36"x24"	4	4	4	4	4	24.0										
W3-5	SPEED REDUCTION	48"x48"	4	4	4	4	4	64.0										
R2-1	SPEED LIMIT XX MPH	48"x60"	4	4	4	4	4	80.0										
R2-11	END HIGHER FINES ZONE	36"x48"	4	4	4	4	4	48.0										
W1-6	LARGE ARROW	60"x30"	12	6	6	12	12	150.0										
R4-1	DO NOT PASS	48"x60"	8	8	8	8	8	160.0										
R10-19aP	PHOTO ENFORCED	48"x36"	4	4	4	4	4	48.0										
R2-6aP	FINES DOUBLE	48"x36"	4	4	4	4	4	48.0										
W21-5a	SHOULDER CLOSED	48"x48"	4	4	4	4	4	64.0										
W4-2	RIGHT LANE ENDS	48"x48"	4	4	4	4	4	64.0										
WZ-1	NOTICE SPEED PHOTO ENFORCED WORK ZONE	84"x60"	4	4	4	4	4	140.0										
SPECIAL	MERGE NOW LEFT	48"x48"	4	4	4	4	4	64.0										
SPECIAL	CONSTRUCTION PROJECT INFORMATION SIGN	48"x96"	2	2	2	2	2	64.0										
SPECIAL	CONSTRUCTION PROJECT INFORMATION SIGN UPDATE					8	2		8									
	TRAFFIC DRUMS		1214	1152	628	1214				1214								
	ADVANCE WARNING ARROW PANEL		220	240	80	540				540								
	PORTABLE CHANGEABLE MESSAGE SIGN		44	48	16	108					108							
	MOBILE SPEED NOTIFICATION SYSTEM (SPECIAL)		2	2	2	2						2						
TOTALS:								1782.0	8	1214	540	108	2					

NOTE: THIS IS A HIGH TRAFFIC VOLUME ROAD AS DEFINED IN SECTION 604.03, STANDARD SPECIFICATIONS FOR HIGHWAY CONSTRUCTION.

NOTE: THE QUANTITY OF TRAFFIC DRUMS PROVIDED IS FOR BOTH SIDES OF THE ROADWAY WITH A MAXIMUM WORK AREA OF 4 MILES. HOWEVER, THE INSTALLATION OF TRAFFIC DRUMS SHALL NEVER EXCEED THE ACTUAL WORK AREA BY MORE THAN 1/4 MILE, UNLESS APPROVED BY THE ENGINEER.

* QUANTITY ESTIMATED.
SEE SECTION 104.03 OF THE STD. SPECS.

CONSTRUCTION PAVEMENT MARKINGS AND PERMANENT PAVEMENT MARKINGS

DESCRIPTION	STAGE 1	STAGE 2	STAGE 3	END OF JOB	CONSTRUCTION PAVEMENT MARKINGS	RAISED PAVEMENT MARKERS		ENHANCED THERMOPLASTIC PAVEMENT MARKING			THERMOPLASTIC PAVEMENT MARKING			REFLECTORIZED PAINT PAVEMENT MARKING			
						TYPE II (WHITE/RED)	6"		12"		12" WHITE	YIELD LINE	WORDS	ARROWS	6"		SYMBOLS (WHEELCHAIR)
							WHITE	YELLOW	WHITE	WHITE					WHITE	YELLOW	
						EACH	WHITE	YELLOW	WHITE	WHITE	WHITE	WHITE	WHITE	WHITE	WHITE	WHITE	WHITE
CONSTRUCTION PAVEMENT MARKINGS	401952	324082	10665		736699												
RAISED PAVEMENT MARKERS TYPE II (WHITE/RED)				5584		5584											
ENHANCED THERMOPLASTIC PAVEMENT MARKING WHITE (6")				430708			430708										
ENHANCED THERMOPLASTIC PAVEMENT MARKING YELLOW (6")				346698				346698									
ENHANCED THERMOPLASTIC PAVEMENT MARKING WHITE (12")				10665					10665								
THERMOPLASTIC PAVEMENT MARKING WHITE (12")				2100						2100							
THERMOPLASTIC PAVEMENT MARKING (YIELD LINE)				30							30						
THERMOPLASTIC PAVEMENT MARKING (WORDS)				4								4					
THERMOPLASTIC PAVEMENT MARKING (ARROWS)				8									8				
REFLECTORIZED PAINT PAVEMENT MARKING WHITE (6")				3300										3300			
REFLECTORIZED PAINT PAVEMENT MARKING YELLOW (6")				1980											1980		
REFLECTORIZED PAINT PAVEMENT MARKING SYMBOLS (WHEELCHAIR)				2												2	
TOTALS:					736699	5584	430708	346698	10665	2100	30	4	8	3300	1980	2	

NOTE: THIS IS A HIGH TRAFFIC VOLUME ROAD AS DEFINED IN SECTION 604.03, STANDARD SPECIFICATIONS FOR HIGHWAY CONSTRUCTION.

R110747_08_QTY_001.DGN SAVED: 7/30/2025



SPALL REPAIR OF PORTLAND CEMENT CONCRETE PAVEMENT

LOG MILE	LOG MILE	LOCATION	* TON
0.048	0.107	I-40/HWY. 261 - WESTBOUND ENT. RAMP	5.00
0.180	0.249	I-40/HWY. 261 - WESTBOUND EXIT RAMP	5.00
TOTAL:			10.00

* QUANTITY ESTIMATED.
SEE SECTION 104.03 OF THE STD. SPECS.
TO BE USED IF AND WHERE DIRECTED BY THE ENGINEER.

RUMBLE STRIPS IN ASPHALT SHOULDERS

LOG MILE	LOG MILE	LOCATION	* RUMBLE STRIPS IN ASPHALT SHOULDERS
			LIN.FT.
I-40 MAIN LANES - WESTBOUND			
ENTIRE PROJECT		INSIDE SHOULDER	157180
ENTIRE PROJECT		OUTSIDE SHOULDER	157180
I-40 MAIN LANES - EASTBOUND			
ENTIRE PROJECT		INSIDE SHOULDER	157180
ENTIRE PROJECT		OUTSIDE SHOULDER	157180
TOTAL:			628720

* QUANTITY ESTIMATED.
SEE SECTION 104.03 OF THE STD. SPECS.
TO BE USED IF AND WHERE DIRECTED BY THE ENGINEER.

ASPHALT CONCRETE PATCHING FOR MAINTENANCE OF TRAFFIC

LOCATION	TON	TACK COAT
		GALLON
ENTIRE PROJECT - TO BE USED IF AND WHERE DIRECTED BY THE ENGINEER	750	1500
TOTALS:	750	1500

BASIS OF ESTIMATE:
ASPHALT CONCRETE PATCHING FOR MAINTENANCE OF TRAFFIC..... 25 TON/MILE
TACK COAT FOR MAINTENANCE OF TRAFFIC..... 50 GAL./MILE

ACHM PATCHING OF EXISTING ROADWAY

DESCRIPTION	TON
ENTIRE PROJECT - TO BE USED IF AND WHERE DIRECTED BY THE ENGINEER	3000
TOTAL:	3000

NOTE: QUANTITY ESTIMATED.
SEE SECTION 104.03 OF THE STD. SPECS.

SHOULDER REPAIR

LOG MILE	LOG MILE	LOCATION	LENGTH	WIDTH	DEPTH	AGGERGATE BASE COURSE (CLASS 7)	TRENCHING AND SHOULDER PREPARATION
			LIN. FT.	LIN. FT.	IN.	TON	STA.
0.048	0.065	I-40/HWY. 261 - WESTBOUND ENT. RAMP INSIDE SHOULDER	90	4	10	23	1
TOTALS:						23	1

NOTE: DEPTH IS THE THICKNESS OF AGGERGATE BASE COURSE TO BE PLACED.
THE TOTAL DEPTH OF THE TRENCH SHALL BE 12" FROM THE TOP OF THE CONCRETE PAVEMENT.

CULVERT REHABILITATION

LOG MILE	DESCRIPTION	* SLIP LINE PIPE ALT. NO. 1			* CEMENTITIOUS PIPE LINER ALT. NO. 2		
		24"	30"	36"	24"	30"	36"
		LIN. FT.					
219.078	24" X 88" C.M. PIPE CULVERT - RT. MAIN LANES	88			88		
219.172	24" X 92" C.M. PIPE CULVERT - RT. MAIN LANES	92			92		
219.456	24" X 88" C.M. PIPE CULVERT - RT. MAIN LANES	88			88		
219.646	24" X 88" C.M. PIPE CULVERT - RT. MAIN LANES	88			88		
219.835	24" X 92" C.M. PIPE CULVERT - RT. MAIN LANES	92			92		
219.987	24" X 88" C.M. PIPE CULVERT - RT. MAIN LANES	88			88		
220.138	24" X 88" C.M. PIPE CULVERT - RT. MAIN LANES	88			88		
220.271	24" X 88" C.M. PIPE CULVERT - LT. MAIN LANES	88			88		
220.384	24" X 88" C.M. PIPE CULVERT - LT. MAIN LANES	88			88		
220.574	24" X 72" C.M. PIPE CULVERT - LT. MAIN LANES	72			72		
220.574	24" X 68" C.M. PIPE CULVERT - RT. MAIN LANES	68			68		
220.763	36" X 82" C.M. PIPE CULVERT - LT. MAIN LANES			82		82	
220.763	36" X 82" C.M. PIPE CULVERT - RT. MAIN LANES			82		82	
221.000	24" X 88" C.M. PIPE CULVERT - LT. MAIN LANES	88			88		
221.369	24" X 82" C.M. PIPE CULVERT - LT. MAIN LANES	82			82		
221.521	24" X 82" C.M. PIPE CULVERT - LT. MAIN LANES	82			82		
221.649	36" X 100" C.M. PIPE CULVERT - LT. MAIN LANES			100		100	
221.649	36" X 100" C.M. PIPE CULVERT - RT. MAIN LANES			100		100	
221.824	24" X 88" C.M. PIPE CULVERT - LT. MAIN LANES	88			88		
221.956	24" X 88" C.M. PIPE CULVERT - LT. MAIN LANES	88			88		
222.051	24" X 82" C.M. PIPE CULVERT - LT. MAIN LANES	82			82		
222.051	24" X 82" C.M. PIPE CULVERT - RT. MAIN LANES	82			82		
222.203	24" X 88" C.M. PIPE CULVERT - LT. MAIN LANES	88			88		
222.297	24" X 88" C.M. PIPE CULVERT - LT. MAIN LANES	88			88		
222.638	24" X 82" C.M. PIPE CULVERT - LT. MAIN LANES	82			82		
222.752	24" X 82" C.M. PIPE CULVERT - LT. MAIN LANES	82			82		
222.998	24" X 80" C.M. PIPE CULVERT - LT. MAIN LANES	80			80		
222.998	24" X 80" C.M. PIPE CULVERT - RT. MAIN LANES	80			80		
223.074	24" X 88" C.M. PIPE CULVERT - LT. MAIN LANES	88			88		
223.263	24" X 88" C.M. PIPE CULVERT - RT. MAIN LANES	88			88		
223.415	24" X 88" C.M. PIPE CULVERT - RT. MAIN LANES	88			88		
223.547	24" X 88" C.M. PIPE CULVERT - RT. MAIN LANES	88			88		
223.680	24" X 88" C.M. PIPE CULVERT - RT. MAIN LANES	88			88		
223.812	24" X 92" C.M. PIPE CULVERT - LT. MAIN LANES	92			92		
224.002	24" X 88" C.M. PIPE CULVERT - LT. MAIN LANES	88			88		
224.096	24" X 88" C.M. PIPE CULVERT - LT. MAIN LANES	88			88		
224.191	24" X 88" C.M. PIPE CULVERT - LT. MAIN LANES	88			88		
224.381	24" X 88" C.M. PIPE CULVERT - RT. MAIN LANES	88			88		
224.703	24" X 88" C.M. PIPE CULVERT - RT. MAIN LANES	88			88		
225.081	24" X 88" C.M. PIPE CULVERT - RT. MAIN LANES	88			88		
225.271	24" X 88" C.M. PIPE CULVERT - RT. MAIN LANES	88			88		
225.536	24" X 88" C.M. PIPE CULVERT - RT. MAIN LANES	88			88		
225.612	24" X 88" C.M. PIPE CULVERT - RT. MAIN LANES	88			88		
225.801	24" X 88" C.M. PIPE CULVERT - RT. MAIN LANES	88			88		
225.990	24" X 88" C.M. PIPE CULVERT - LT. MAIN LANES	88			88		
226.180	24" X 80" C.M. PIPE CULVERT - LT. MAIN LANES	80			80		
226.369	24" X 96" C.M. PIPE CULVERT - LT. MAIN LANES	96			96		
226.530	24" X 88" C.M. PIPE CULVERT - RT. MAIN LANES	88			88		
226.615	24" X 88" C.M. PIPE CULVERT - RT. MAIN LANES	88			88		
226.710	24" X 88" C.M. PIPE CULVERT - RT. MAIN LANES	88			88		
226.899	24" X 88" C.M. PIPE CULVERT - RT. MAIN LANES	88			88		
227.089	24" X 88" C.M. PIPE CULVERT - RT. MAIN LANES	88			88		
227.218	30" X 136" C.M. PIPE CULVERT - LT. MAIN LANES		136			136	
227.218	30" X 136" C.M. PIPE CULVERT - RT. MAIN LANES		136			136	
227.278	24" X 88" C.M. PIPE CULVERT - RT. MAIN LANES	88			88		
227.430	24" X 88" C.M. PIPE CULVERT - RT. MAIN LANES	88			88		
227.733	24" X 84" C.M. PIPE CULVERT - RT. MAIN LANES	84			84		
227.932	24" X 84" C.M. PIPE CULVERT - RT. MAIN LANES	84			84		
228.131	24" X 84" C.M. PIPE CULVERT - RT. MAIN LANES	84			84		
228.320	30" X 82" C.M. PIPE CULVERT - LT. MAIN LANES		82			82	
228.320	30" X 82" C.M. PIPE CULVERT - RT. MAIN LANES		82			82	
228.528	24" X 84" C.M. PIPE CULVERT - RT. MAIN LANES	84			84		
TOTALS:		4660	436	364	4660	436	364

* QUANTITY ESTIMATED.
SEE SECTION 104.03 OF THE STD. SPECS.
TO BE USED IF AND WHERE DIRECTED BY THE ENGINEER.

DATE REVISED	DATE REVISED	FED. RD. DIST. NO.	STATE	JOB NO.	SHEET NO.	TOTAL SHEETS
		6	ARK.	110747	25	30
QUANTITIES						

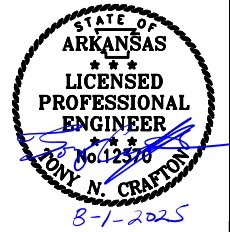

COLD MILLING ASPHALT PAVEMENT

LOG MILE	LOG MILE	LOCATION	AVG. WIDTH	TOTAL LENGTH	COLD MILLING ASPHALT PAVEMENT
			FEET	FEET	SQ. YD.
MAIN LANES - WESTBOUND					
209.555	211.605	I-40 WESTBOUND MAIN LANES	38.00	10824.00	45701.33
211.644	215.985	I-40 WESTBOUND MAIN LANES	38.00	22920.48	96775.36
216.047	217.761	I-40 WESTBOUND MAIN LANES	38.00	9049.92	38210.77
217.785	219.888	I-40 WESTBOUND MAIN LANES	38.00	11103.84	46882.88
219.926	226.184	I-40 WESTBOUND MAIN LANES	38.00	33042.24	139511.68
226.221	233.965	I-40 WESTBOUND MAIN LANES	38.00	40888.32	172639.57
234.129	237.729	I-40 WESTBOUND MAIN LANES	38.00	19008.00	80256.00
237.759	239.417	I-40 WESTBOUND MAIN LANES	38.00	8754.24	36962.35
239.448	239.749	I-40 WESTBOUND MAIN LANES	38.00	1589.28	6710.29
MAIN LANES - EASTBOUND					
209.555	211.605	I-40 EASTBOUND MAIN LANES	38.00	10824.00	45701.33
211.644	215.984	I-40 EASTBOUND MAIN LANES	38.00	22915.20	96753.07
216.046	217.754	I-40 EASTBOUND MAIN LANES	38.00	9018.24	38077.01
217.778	219.888	I-40 EASTBOUND MAIN LANES	38.00	11140.80	47038.93
219.926	226.184	I-40 EASTBOUND MAIN LANES	38.00	33042.24	139511.68
226.221	233.965	I-40 EASTBOUND MAIN LANES	38.00	40888.32	172639.57
234.129	237.749	I-40 EASTBOUND MAIN LANES	38.00	19113.60	80701.87
237.779	239.438	I-40 EASTBOUND MAIN LANES	38.00	8759.52	36984.64
239.469	239.749	I-40 EASTBOUND MAIN LANES	38.00	1478.40	6242.13
MAIN LANES - WESTBOUND RAMPS					
215.511	215.598	I-40 HWY. 49 - WESTBOUND ACCELERATION TAPER	4.00	459.36	204.16
215.598	215.695	I-40 HWY. 49 - WESTBOUND ACCELERATION LANE	8.00	512.16	455.25
0.006	0.027	I-40 HWY. 49 - WESTBOUND 1 LANE ENT. RAMP VAR. WIDTH TURNOUT	40.10	110.88	494.03
0.027	0.100	I-40 HWY. 49 - WESTBOUND 1 LANE ENT. RAMP WITH ISLAND	21.00	385.44	899.36
0.100	0.232	I-40 HWY. 49 - WESTBOUND ENT. RAMP	25.00	696.96	1936.00
0.000	0.064	I-40 HWY. 49 - WESTBOUND EXIT RAMP VAR. WIDTH	20.00	337.92	750.93
0.064	0.181	I-40 HWY. 49 - WESTBOUND EXIT RAMP	25.00	617.76	1716.00
0.181	0.263	I-40 HWY. 49 - WESTBOUND 1 LANE EXIT RAMP WITH ISLAND	21.00	432.96	1010.24
0.263	0.279	I-40 HWY. 49 - WESTBOUND 1 LANE EXIT RAMP VAR. WIDTH TURNOUT	32.00	84.48	300.37
220.610	220.682	I-40 HWY. 78 - WESTBOUND ACCELERATION TAPER	4.00	380.16	168.96
220.682	220.810	I-40 HWY. 78 - WESTBOUND ACCELERATION LANE	8.00	675.84	600.75
0.001	0.016	I-40 HWY. 78 - WESTBOUND ENT. RAMP VAR. WIDTH TURNOUT	58.90	79.20	518.32
0.016	0.205	I-40 HWY. 78 - WESTBOUND ENT. RAMP	25.00	997.92	2772.00
0.007	0.086	I-40 HWY. 78 - WESTBOUND EXIT RAMP VAR. WIDTH	18.10	417.12	838.87
0.086	0.254	I-40 HWY. 78 - WESTBOUND EXIT RAMP	25.00	887.04	2464.00
0.254	0.266	I-40 HWY. 78 - WESTBOUND EXIT RAMP VAR. WIDTH TURNOUT	52.60	63.36	370.30
232.810	232.877	I-40 HWY. 261 - WESTBOUND ACCELERATION TAPER	4.00	353.76	157.23
232.877	232.992	I-40 HWY. 261 - WESTBOUND ACCELERATION LANE	8.00	607.20	539.73
0.003	0.013	I-40 HWY. 261 - WESTBOUND ENT. RAMP VAR. WIDTH TURNOUT	53.10	52.80	311.52
0.013	0.048	I-40 HWY. 261 - WESTBOUND ENT. RAMP	25.00	184.80	513.33
0.048	0.107	I-40 HWY. 261 - WESTBOUND ENT. RAMP LT. & RT. SHOULDERS	10.00	311.52	346.13
0.107	0.220	I-40 HWY. 261 - WESTBOUND ENT. RAMP	25.00	596.64	1657.33
0.220	0.105	I-40 HWY. 261 - WESTBOUND EXIT RAMP VAR. WIDTH	20.10	438.24	978.74
0.105	0.180	I-40 HWY. 261 - WESTBOUND EXIT RAMP	25.00	396.00	1100.00
0.180	0.249	I-40 HWY. 261 - WESTBOUND EXIT RAMP LT. & RT. SHOULDERS	10.00	364.32	404.80
0.249	0.289	I-40 HWY. 261 - WESTBOUND EXIT RAMP	25.00	211.20	586.67
0.289	0.297	I-40 HWY. 261 - WESTBOUND EXIT RAMP VAR. WIDTH TURNOUT	58.40	42.24	274.09
238.625	238.692	I-40 HWY. 1 - WESTBOUND ACCELERATION TAPER	4.00	353.76	157.23
238.692	238.824	I-40 HWY. 1 - WESTBOUND ACCELERATION LANE	8.00	696.96	619.52
0.006	0.033	I-40 HWY. 1 - WESTBOUND ENT. RAMP VAR. WIDTH TURNOUT	44.20	142.56	700.13
0.033	0.342	I-40 HWY. 1 - WESTBOUND ENT. RAMP	25.00	1631.52	4532.00
0.342	0.090	I-40 HWY. 1 - WESTBOUND EXIT RAMP VAR. WIDTH	18.60	380.16	785.66
0.090	0.310	I-40 HWY. 1 - WESTBOUND EXIT RAMP	25.00	1161.60	3226.67
0.310	0.333	I-40 HWY. 1 - WESTBOUND EXIT RAMP VAR. WIDTH TURNOUT	52.60	121.44	709.75
MAIN LANES - EASTBOUND RAMPS					
0.004	0.068	I-40 HWY. 49 - EASTBOUND EXIT RAMP VAR. WIDTH	15.60	337.92	585.73
0.068	0.227	I-40 HWY. 49 - EASTBOUND EXIT RAMP	25.00	839.52	2332.00
0.227	0.280	I-40 HWY. 49 - EASTBOUND 2 LANE EXIT RAMP WITH ISLAND	33.00	279.84	1026.08
0.280	0.297	I-40 HWY. 49 - EASTBOUND 2 LANE EXIT RAMP VAR. WIDTH TURNOUT	48.80	89.76	486.70
0.005	0.024	I-40 HWY. 49 - EASTBOUND 1 LANE ENT. RAMP VAR. WIDTH TURNOUT	34.50	100.32	384.56
0.024	0.073	I-40 HWY. 49 - EASTBOUND 1 LANE ENT. RAMP WITH ISLAND	21.00	258.72	603.68
0.073	0.214	I-40 HWY. 49 - EASTBOUND ENT. RAMP	25.00	744.48	2068.00
215.624	215.738	I-40 HWY. 49 - EASTBOUND ACCELERATION LANE	8.00	601.92	535.04
215.738	215.815	I-40 HWY. 49 - EASTBOUND ACCELERATION TAPER	4.00	406.56	180.69
0.013	0.092	I-40 HWY. 78 - EASTBOUND EXIT RAMP VAR. WIDTH	16.50	417.12	857.41
0.092	0.260	I-40 HWY. 78 - EASTBOUND EXIT RAMP	25.00	887.04	2464.00
0.260	0.272	I-40 HWY. 78 - EASTBOUND EXIT RAMP VAR. WIDTH TURNOUT	47.10	63.36	331.58
0.003	0.015	I-40 HWY. 78 - EASTBOUND ENT. RAMP VAR. WIDTH TURNOUT	50.90	63.36	358.34
0.015	0.212	I-40 HWY. 78 - EASTBOUND ENT. RAMP	25.00	1040.16	2889.33
221.098	221.221	I-40 HWY. 78 - EASTBOUND ACCELERATION LANE	8.00	649.44	577.28
221.221	221.284	I-40 HWY. 78 - EASTBOUND ACCELERATION TAPER	4.00	332.64	147.84
0.000	0.072	I-40 HWY. 261 - EASTBOUND EXIT RAMP VAR. WIDTH	19.60	380.16	827.90
0.072	0.253	I-40 HWY. 261 - EASTBOUND EXIT RAMP	25.00	955.68	2654.67
0.253	0.264	I-40 HWY. 261 - EASTBOUND EXIT RAMP VAR. WIDTH TURNOUT	50.90	58.08	328.47
0.002	0.013	I-40 HWY. 261 - EASTBOUND ENT. RAMP VAR. WIDTH TURNOUT	54.40	58.08	351.06
0.013	0.185	I-40 HWY. 261 - EASTBOUND ENT. RAMP	25.00	908.16	2522.67
233.304	233.412	I-40 HWY. 261 - EASTBOUND ACCELERATION LANE	8.00	570.24	506.88
233.412	233.475	I-40 HWY. 261 - EASTBOUND ACCELERATION TAPER	4.00	332.64	147.84
0.028	0.089	I-40 REST AREA - EASTBOUND EXIT RAMP VAR. WIDTH TURNOUT	16.30	322.08	583.32
0.089	0.227	I-40 REST AREA - EASTBOUND EXIT RAMP	25.00	728.64	2024.00
0.000	0.135	I-40 REST AREA - EASTBOUND ENT. RAMP	25.00	712.80	1980.00
235.918	236.012	I-40 REST AREA - EASTBOUND ACCELERATION LANE	8.00	496.32	441.17
236.012	236.075	I-40 REST AREA - EASTBOUND ACCELERATION TAPER	4.00	332.64	147.84
0.010	0.083	I-40 HWY. 1 - EASTBOUND EXIT RAMP VAR. WIDTH	17.20	385.44	736.62
0.083	0.269	I-40 HWY. 1 - EASTBOUND EXIT RAMP	25.00	982.08	2728.00
0.269	0.293	I-40 HWY. 1 - EASTBOUND EXIT RAMP VAR. WIDTH TURNOUT	55.30	126.72	778.62
0.009	0.025	I-40 HWY. 1 - EASTBOUND ENT. RAMP VAR. WIDTH TURNOUT	66.90	84.48	627.97
0.025	0.340	I-40 HWY. 1 - EASTBOUND ENT. RAMP	25.00	1663.20	4620.00
239.165	239.286	I-40 HWY. 1 - EASTBOUND ACCELERATION LANE	8.00	638.88	567.89
239.286	239.353	I-40 HWY. 1 - EASTBOUND ACCELERATION TAPER	4.00	353.76	157.23
REST AREA					
0.019	0.117	I-40 EASTBOUND REST AREA ROAD	25.00	517.44	1437.33
0.117	0.127	PARKING 1	20.00	53.00	117.78
0.117	0.125	PARKING 2	20.00	43.00	95.56
0.117	0.337	I-40 EASTBOUND REST AREA PASSENGER VEHICLE LANE	18.00	1161.60	2323.20
0.159	0.167	PARKING 3	19.00	43.00	90.78
0.167	0.179	PARKING 4	19.00	64.00	135.11
0.198	0.207	MAINTENANCE DRIVEWAY	18.00	48.00	96.00
0.204	0.226	PARKING 5	19.00	117.00	247.00
0.226	0.236	PARKING 6	19.00	53.00	111.89
0.246	0.254	PARKING 7	19.00	43.00	90.78
0.277	0.292	PARKING 8	19.00	80.00	168.89
0.316	0.326	PARKING 9	19.00	53.00	111.89
0.327	0.337	PARKING 10	19.00	53.00	111.89
0.337	0.393	I-40 EASTBOUND REST AREA ROAD	25.00	295.68	821.33
TOTAL:					1404920.37

NOTE: COORDINATE COLD MILLING STOCKPILE LOCATIONS WITH DISTRICT ENGINEER. STOCKPILE LOCATIONS SHALL BE NO FURTHER THAN FIVE MILES FROM EACH SITE.

QUANTITIES

DATE REVISED	DATE REVISED	FED. RD. DIST. NO.	STATE	JOB NO.	SHEET NO.	TOTAL SHEETS
		6	ARK.	110747	26	30
QUANTITIES						



LOG MILE	LOG MILE	LOCATION	LENGTH FEET	* RECLAIMED AGGREGATE		TACK COAT (0.17 GAL. PER SQ. YD.)			ACHM SURFACE COURSE (1/2")							
				TON STATION	TON	TOTAL WID. FEET		TOTAL GALLONS	AVG. WID. FEET	SQ. YD.	POUND / SQ. YD.	PG 64-22 TON	PG 76-22 TON	TOTAL PG 64-22 TON	TOTAL PG 76-22 TON	
						TON	TON									SQ. YD.
MAIN LANES - WESTBOUND																
209.555	211.605	L40 WESTBOUND MAIN LANES	10824.00	3.00	324.72	38.00	45701.33	7769.23	7769.23	38.00	45701.33	220.00		5027.15		5027.15
211.644	215.985	L40 WESTBOUND MAIN LANES	22920.48	3.00	687.61	38.00	96775.36	16451.81	16451.81	38.00	96775.36	220.00		10645.29		10645.29
216.047	217.761	L40 WESTBOUND MAIN LANES	9049.92	3.00	271.50	38.00	38210.77	6495.83	6495.83	38.00	38210.77	220.00		4203.18		4203.18
217.795	219.889	L40 WESTBOUND MAIN LANES	11103.84	3.00	333.12	38.00	46882.88	7970.09	7970.09	38.00	46882.88	220.00		5157.12		5157.12
219.926	226.184	L40 WESTBOUND MAIN LANES	33042.24	3.00	991.27	38.00	139511.68	23716.99	23716.99	38.00	139511.68	220.00		15346.28		15346.28
226.221	233.965	L40 WESTBOUND MAIN LANES	40888.32	3.00	1226.65	38.00	172639.57	29348.73	29348.73	38.00	172639.57	220.00		18990.35		18990.35
234.129	237.729	L40 WESTBOUND MAIN LANES	19008.00	3.00	570.24	38.00	80256.00	13643.52	13643.52	38.00	80256.00	220.00		8828.16		8828.16
237.759	239.417	L40 WESTBOUND MAIN LANES	8754.24	3.00	262.63	38.00	36962.35	6283.60	6283.60	38.00	36962.35	220.00		4065.86		4065.86
239.448	239.749	L40 WESTBOUND MAIN LANES	1589.28	3.00	47.68	38.00	6710.29	1140.75	1140.75	38.00	6710.29	220.00		738.13		738.13
MAIN LANES - EASTBOUND																
209.555	211.605	L40 EASTBOUND MAIN LANES	10824.00	3.00	324.72	38.00	45701.33	7769.23	7769.23	38.00	45701.33	220.00		5027.15		5027.15
211.644	215.984	L40 EASTBOUND MAIN LANES	22915.20	3.00	687.46	38.00	96753.07	16448.02	16448.02	38.00	96753.07	220.00		10642.84		10642.84
216.046	217.754	L40 EASTBOUND MAIN LANES	9018.24	3.00	270.55	38.00	38077.01	6473.09	6473.09	38.00	38077.01	220.00		4188.47		4188.47
217.778	219.888	L40 EASTBOUND MAIN LANES	11140.80	3.00	334.22	38.00	47038.93	7996.62	7996.62	38.00	47038.93	220.00		5174.28		5174.28
219.926	226.184	L40 EASTBOUND MAIN LANES	33042.24	3.00	991.27	38.00	139511.68	23716.99	23716.99	38.00	139511.68	220.00		15346.28		15346.28
226.221	233.965	L40 EASTBOUND MAIN LANES	40888.32	3.00	1226.65	38.00	172639.57	29348.73	29348.73	38.00	172639.57	220.00		18990.35		18990.35
234.129	237.749	L40 EASTBOUND MAIN LANES	19113.60	3.00	573.41	38.00	80701.87	13719.32	13719.32	38.00	80701.87	220.00		8877.21		8877.21
237.779	239.438	L40 EASTBOUND MAIN LANES	8759.52	3.00	262.79	38.00	36984.64	6287.39	6287.39	38.00	36984.64	220.00		4068.31		4068.31
239.469	239.749	L40 EASTBOUND MAIN LANES	1478.40	3.00	44.35	38.00	6242.13	1061.16	1061.16	38.00	6242.13	220.00		686.63		686.63
MAIN LANES - WESTBOUND RAMP																
215.511	215.598	L40 HWY. 49 - WESTBOUND ACCELERATION TAPER	459.36			4.00	204.16	34.71	34.71	4.00	204.16	220.00		22.46		22.46
215.598	215.695	L40 HWY. 49 - WESTBOUND ACCELERATION LANE	512.16			8.00	455.25	77.39	77.39	8.00	455.25	220.00		50.08		50.08
0.026	0.027	L40 HWY. 49 - WESTBOUND 1 LANE ENT. RAMP VAR. WIDTH TURNOUT	110.88	4.00	4.44	40.10	494.03	83.99	83.99	40.10	494.03	220.00		54.34		54.34
0.027	0.100	L40 HWY. 49 - WESTBOUND 1 LANE ENT. RAMP WITH ISLAND	385.44	2.00	7.71	21.00	899.36	152.89	152.89	21.00	899.36	220.00		98.93		98.93
0.100	0.232	L40 HWY. 49 - WESTBOUND ENT. RAMP	696.96	4.00	27.88	25.00	1936.00	329.12	329.12	25.00	1936.00	220.00		212.96		212.96
0.000	0.064	L40 HWY. 49 - WESTBOUND EXIT RAMP VAR. WIDTH	337.92	4.00	13.52	20.00	750.93	127.66	127.66	20.00	750.93	220.00		82.60		82.60
0.064	0.181	L40 HWY. 49 - WESTBOUND EXIT RAMP	617.76	4.00	24.71	25.00	1716.00	291.72	291.72	25.00	1716.00	220.00		188.76		188.76
0.181	0.263	L40 HWY. 49 - WESTBOUND 1 LANE EXIT RAMP WITH ISLAND	432.96	2.00	8.66	21.00	1010.24	171.74	171.74	21.00	1010.24	220.00		111.13		111.13
0.263	0.279	L40 HWY. 49 - WESTBOUND 1 LANE EXIT RAMP WITH TURNOUT	84.48	4.00	3.38	32.00	300.37	51.06	51.06	32.00	300.37	220.00		33.04		33.04
220.610	220.682	L40 HWY. 78 - WESTBOUND ACCELERATION TAPER	380.16			4.00	168.96	28.72	28.72	4.00	168.96	220.00		18.59		18.59
220.682	220.810	L40 HWY. 78 - WESTBOUND ACCELERATION LANE	675.84			8.00	600.75	102.13	102.13	8.00	600.75	220.00		66.08		66.08
0.001	0.016	L40 HWY. 78 - WESTBOUND ENT. RAMP VAR. WIDTH TURNOUT	79.20	4.00	3.17	58.90	272.32	88.11	88.11	58.90	272.32	220.00		57.02		57.02
0.016	0.205	L40 HWY. 78 - WESTBOUND ENT. RAMP	997.92	4.00	39.52	25.00	2772.00	471.24	471.24	25.00	2772.00	220.00		304.92		304.92
0.205	0.086	L40 HWY. 78 - WESTBOUND EXIT RAMP VAR. WIDTH	417.12	4.00	16.68	18.10	838.87	142.61	142.61	18.10	838.87	220.00		92.28		92.28
0.086	0.254	L40 HWY. 78 - WESTBOUND EXIT RAMP	887.04	4.00	35.48	25.00	2464.00	418.88	418.88	25.00	2464.00	220.00		271.04		271.04
0.254	0.266	L40 HWY. 78 - WESTBOUND EXIT RAMP VAR. WIDTH TURNOUT	63.36	4.00	2.53	52.60	370.30	62.95	62.95	52.60	370.30	220.00		40.73		40.73
232.810	232.877	L40 HWY. 261 - WESTBOUND ACCELERATION TAPER	353.76			4.00	157.23	26.73	26.73	4.00	157.23	220.00		17.30		17.30
232.877	232.992	L40 HWY. 261 - WESTBOUND ACCELERATION LANE	607.20			8.00	539.73	91.75	91.75	8.00	539.73	220.00		59.37		59.37
0.003	0.013	L40 HWY. 261 - WESTBOUND ENT. RAMP VAR. WIDTH TURNOUT	52.80	4.00	2.11	53.10	311.52	52.96	52.96	53.10	311.52	220.00		34.27		34.27
0.013	0.048	L40 HWY. 261 - WESTBOUND ENT. RAMP	184.80	4.00	7.39	25.00	513.33	87.27	87.27	25.00	513.33	220.00		56.47		56.47
0.048	0.107	L40 HWY. 261 - WESTBOUND ENT. RAMP	311.52	4.00	12.46	25.00	865.33	147.11	147.11	25.00	865.33	220.00		95.19		95.19
0.107	0.107	L40 HWY. 261 - WESTBOUND ENT. RAMP LT. & RT. SHOULDERS	311.52	4.00						10.00	346.13	220.00		38.07		38.07
0.107	0.220	L40 HWY. 261 - WESTBOUND ENT. RAMP	596.64	4.00	23.87	25.00	1657.33	281.75	281.75	25.00	1657.33	220.00		182.31		182.31
0.220	0.105	L40 HWY. 261 - WESTBOUND EXIT RAMP VAR. WIDTH	438.24	4.00	17.53	20.10	978.74	166.39	166.39	20.10	978.74	220.00		107.66		107.66
0.105	0.180	L40 HWY. 261 - WESTBOUND EXIT RAMP	396.00	4.00	15.84	25.00	1100.00	187.00	187.00	25.00	1100.00	220.00		121.00		121.00
0.180	0.249	L40 HWY. 261 - WESTBOUND EXIT RAMP	364.32	4.00	14.57	25.00	1012.00	172.04	172.04	25.00	1012.00	220.00		111.32		111.32
0.249	0.249	L40 HWY. 261 - WESTBOUND EXIT RAMP LT. & RT. SHOULDERS	364.32							10.00	404.80	220.00		44.53		44.53
0.249	0.289	L40 HWY. 261 - WESTBOUND EXIT RAMP	211.20	4.00	8.45	25.00	586.67	99.73	99.73	25.00	586.67	220.00		64.53		64.53
0.289	0.297	L40 HWY. 261 - WESTBOUND EXIT RAMP VAR. WIDTH TURNOUT	42.24	4.00	1.69	58.40	274.09	46.60	46.60	58.40	274.09	220.00		30.15		30.15
238.625	238.692	L40 HWY. 1 - WESTBOUND ACCELERATION TAPER	353.76			4.00	157.23	26.73	26.73	4.00	157.23	220.00		17.30		17.30
238.692	238.824	L40 HWY. 1 - WESTBOUND ACCELERATION LANE	696.96			8.00	619.52	105.32	105.32	8.00	619.52	220.00		68.15		68.15
0.006	0.033	L40 HWY. 1 - WESTBOUND ENT. RAMP VAR. WIDTH TURNOUT	142.56	4.00	5.70	44.20	700.13	119.02	119.02	44.20	700.13	220.00		77.01		77.01
0.033	0.342	L40 HWY. 1 - WESTBOUND ENT. RAMP	1631.52	4.00	65.26	25.00	4532.00	770.44	770.44	25.00	4532.00	220.00		498.52		498.52
0.342	0.090	L40 HWY. 1 - WESTBOUND EXIT RAMP VAR. WIDTH	380.16	4.00	15.21	18.60	785.66	133.56	133.56	18.60	785.66	220.00		86.42		86.42
0.090	0.310	L40 HWY. 1 - WESTBOUND EXIT RAMP	1161.60	4.00	46.46	25.00	3226.67	543.53	543.53	25.00	3226.67	220.00		354.93		354.93
0.310	0.333	L40 HWY. 1 - WESTBOUND EXIT RAMP VAR. WIDTH TURNOUT	121.44	4.00	4.86	52.60	708.75	120.66	120.66	52.60	708.75	220.00		78.07		78.07
MAIN LANES - EASTBOUND RAMP																
0.004	0.068	L40 HWY. 49 - EASTBOUND EXIT RAMP VAR. WIDTH	337.92	4.00	13.52	15.60	585.73	99.57	99.57	15.60	585.73	220.00		64.43		64.43
0.068	0.227	L40 HWY. 49 - EASTBOUND EXIT RAMP	839.52	4.00	33.58	25.00	2332.00	396.44	396.44	25.00	2332.00	220.00		256.52		256.52
0.227	0.280	L40 HWY. 49 - EASTBOUND 2 LANE EXIT RAMP WITH ISLAND	279.84	2.00	5.60	33.00	1026.08	174.43	174.43	33.00	1026.08	220.00		112.87		112.87
0.280	0.297	L40 HWY. 49 - EASTBOUND 2 LANE EXIT RAMP VAR. WIDTH TURNOUT	89.76	4.00	3.59	48.80	486.70	82.74	82.74	48.80	486.70	220.00		53.54		53.54

DATE REVISED	DATE REVISED	FED. RD. DIST. NO.	STATE	JOB NO.	SHEET NO.	TOTAL SHEETS
		6	ARK.	110747	27	30
DISTRICT 1 BRIDGES - QUANTITIES - 64155						

SCHEDULE OF BRIDGE QUANTITIES - JOB NO. 110747

DISTRICT	SITE NO.	COUNTY	ROUTE	SECTION	LOG MILE	BRIDGE NO.	SS & 809	821	SP JOB 110747
							SILICONE JOINT SEALANT	MODIFICATION OF EXISTING BRIDGE STRUCTURE (BRIDGE NO. _____)	BRIDGE BACKWALL MODIFICATION
							LIN. FT.	LUMP SUM	SQ. FT.
1	1	MONROE	I-40	43	209.298	B3724 ①		1 ③	
	6	MONROE	I-40	43	215.992	A3731 ①	87 ②		12 ④
TOTALS FOR JOB 110747							87		12

Note: Site Nos. 2-5 and 7-18 are project exceptions. See Roadway plans for additional information.

REFERENCE TABLE

BRIDGE NO.	EXISTING DWG. NO(S).
B3724	35720-35721
A3731	37989, 37994, 37995

- ① EXISTING BRIDGE DECK HAS POLYMER OVERLAY FROM JOB BB0102.
- ② EXISTING BRIDGE HAS FILLED JOINTS TO BE REMOVED AND REPLACED WITH POURED SILICONE JOINTS.
- ③ MODIFICATION OF EXISTING BRIDGE STRUCTURE INCLUDES REMOVAL AND REPLACEMENT OF NEOPRENE STRIP SEAL JOINT MATERIAL AT BENTS 1, 8, 16, & 23.
- ④ SEE DWG. NO. 64157 FOR DETAILS OF BACKWALL MODIFICATION. DEPTH OF REPAIR IS ESTIMATED TO BE 2".

Tony.Crofton 8/1/2024 161836
 WORKSPACE: \\pds01\geogis\jrc\110747_01.dgn
 c:\user's\public\mbp\15\010102\110747_01.dgn
 REVISED DATE:

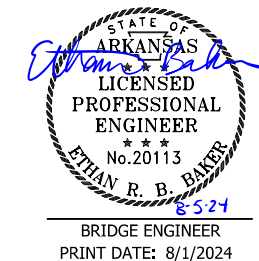

SCHEDULE OF BRIDGE QUANTITIES
BAYOU DEVIEW - FORREST CITY (S)
 ROUTE I-40 SECTION 43
ARKANSAS STATE HIGHWAY COMMISSION
 LITTLE ROCK, ARK.

DRAWN BY: MHA DATE: 3/2024 FILENAME: B110747_Q1.DGN
 CHECKED BY: MKL DATE: 3/2024 SCALE: NONE
 DESIGNED BY: MHA DATE: 3/2024
 BRIDGE NO. DISTRICT 1 BRIDGES DRAWING NO. 64155

BRIDGE ENGINEER
 PRINT DATE: 8/1/2024

DATE REVISED	DATE REVISED	FED. RD. DIST. NO.	STATE	JOB NO.	SHEET NO.	TOTAL SHEETS
10-08-25		6	ARK.	110747	28	30
11-04-25						
SUMMARY OF QUANTITIES AND REVISIONS						

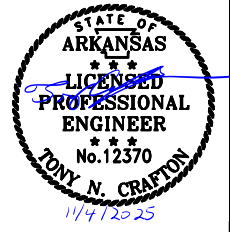

SUMMARY OF QUANTITIES

ITEM NUMBER	ITEM	QUANTITY	UNIT
SP & 215	TRENCHING AND SHOULDER PREPARATION	1	STATION
SP, SS, & 303	AGGREGATE BASE COURSE (CLASS 7)	23	TON
SS & 401	TACK COAT	240528	GAL.
SP, SS, & 407	MINERAL AGGREGATE IN ACHM SURFACE COURSE (1/2")	145928	TON
SP, SS, & 407	ASPHALT BINDER (PG 64-22) IN ACHM SURFACE COURSE (1/2")	37	TON
SP, SS, & 407	ASPHALT BINDER (PG 76-22) IN ACHM SURFACE COURSE (1/2")	8783	TON
SP & 412	COLD MILLING ASPHALT PAVEMENT	1404920	SQ. YD.
SP	RECLAIMED AGGREGATE	10349	TON
SP, SS, & 414	ASPHALT CONCRETE PATCHING FOR MAINTENANCE OF TRAFFIC	750	TON
SP, SS, & 415	ACHM PATCHING OF EXISTING ROADWAY	3000	TON
601	MOBILIZATION	1.00	LUMP SUM
SP & 602	FURNISHING FIELD OFFICE	1	EACH
SP, SS, & 603	MAINTENANCE OF TRAFFIC	1.00	LUMP SUM
SS & 604	SIGNS	1782	SQ. FT.
SP, SS, & 604	CONSTRUCTION PROJECT INFORMATION SIGN UPDATE	8	EACH
SS & 604	TRAFFIC DRUMS	1214	EACH
604	CONSTRUCTION PAVEMENT MARKINGS	736699	LIN. FT.
SS & 604	ADVANCE WARNING ARROW PANEL	540	DAY
SP, SS, & 604	PORTABLE CHANGEABLE MESSAGE SIGN	108	WEEK
SP	MOBILE SPEED NOTIFICATION SYSTEM (SPECIAL)	2	EACH
* SP	SLIP LINE PIPE (24") (ALTERNATE NO. 1)	4660	LIN. FT.
* SP	CEMENTITIOUS PIPE LINER (24") (ALTERNATE NO. 2)	4660	LIN. FT.
* SP	SLIP LINE PIPE (30") (ALTERNATE NO. 1)	436	LIN. FT.
* SP	CEMENTITIOUS PIPE LINER (30") (ALTERNATE NO. 2)	436	LIN. FT.
* SP	SLIP LINE PIPE (36") (ALTERNATE NO. 1)	364	LIN. FT.
* SP	CEMENTITIOUS PIPE LINER (36") (ALTERNATE NO. 2)	364	LIN. FT.
635	ROADWAY CONSTRUCTION CONTROL	1.00	LUMP SUM
642	RUMBLE STRIPS IN ASPHALT SHOULDERS	628720	LIN. FT.
718	REFLECTORIZED PAINT PAVEMENT MARKING WHITE (6")	3300	LIN. FT.
718	REFLECTORIZED PAINT PAVEMENT MARKING YELLOW (6")	1980	LIN. FT.
718	REFLECTORIZED PAINT PAVEMENT MARKING SYMBOLS (WHEELCHAIR)	2	EACH
719	THERMOPLASTIC PAVEMENT MARKING WHITE (12")	2100	LIN. FT.
719	THERMOPLASTIC PAVEMENT MARKING (YIELD LINE)	30	LIN. FT.
719	THERMOPLASTIC PAVEMENT MARKING (WORDS)	4	EACH
719	THERMOPLASTIC PAVEMENT MARKING (ARROWS)	8	EACH
SP	ENHANCED THERMOPLASTIC PAVEMENT MARKING WHITE (6")	430708	LIN. FT.
SP	ENHANCED THERMOPLASTIC PAVEMENT MARKING WHITE (12")	10665	LIN. FT.
SP	ENHANCED THERMOPLASTIC PAVEMENT MARKING YELLOW (6")	346698	LIN. FT.
721	RAISED PAVEMENT MARKERS (TYPE II)	5584	EACH
SP	SPALL REPAIR OF PORTLAND CEMENT CONCRETE PAVEMENT	10	TON
STRUCTURES OVER 20' SPAN			
SS & 809	SILICONE JOINT SEALANT	87	LIN. FT.
821	MODIFICATION OF EXISTING BRIDGE STRUCTURE (BRIDGE NO. B3724)	1	LUMP SUM
SP	BRIDGE BACKWALL MODIFICATION	12	SQ. FT.

* DENOTES ALTERNATE BID ITEMS.

REVISIONS

DATE	REVISION	SHEET NUMBER
10/08/2025	"REPLACED THE SITE USE (A+C METHOD) - CALENDAR DAY CONTRACT WITH THE NO PROSECUTION VERSION."	28
11/04/2025	"REVISED THE CULVERT REHABILITATION SPECIAL PROVISION"	28

R110747_08_SUMQTY_001.DGN SAVED: 11/4/2025

DATE REVISED	DATE REVISED	FED. RD. DIST. NO.	STATE	JOB NO.	SHEET NO.	TOTAL SHEETS
		6	ARK.	110747	29	30
DISTRICT 1 BRIDGES - BRIDGE DATA - 64156						

**BRIDGE PRESERVATION DATA TABLE
(DISTRICT 1)**

CURRENT CONST. CONTRACT SITE NO.	BRIDGE NO.	ORIGINAL CONTRACT NO.	COUNTY	ROUTE	SECTION	BRIDGE JOINT TREATMENT STD. DRAWING	BRIDGE JOINT TREATMENT LOCATION
1	B3724	R10085	MONROE	I-40	43	55064	BENTS 1, 8, 16, & 23
6	A3731	R10055	MONROE	I-40	43	55064 WITH BACKWALL MODIFICATION. SEE DWG. NO. 64157	BACKWALL MODIFICATION: BENT 1 55064: BENT 4

Note: Site Nos. 2-5 and 7-18 are project exceptions. See Roadway plans for additional information.

Tony.Crafton 8/1/2024 161855
 WORKSPACE: c:\user\tony\public\mb\p\16\10150162\B010747.DT.dgn
 REVISED DATE:

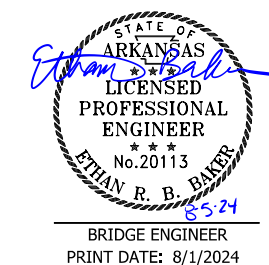

BRIDGE PRESERVATION DATA TABLE
DISTRICT 1
 ROUTE I-40 SECTION 43
ARKANSAS STATE HIGHWAY COMMISSION
 LITTLE ROCK, ARK.

DRAWN BY: MHA DATE: 3/2024 FILENAME: B110747_DT.DGN
 CHECKED BY: MKL DATE: 3/2024 SCALE: NONE
 DESIGNED BY: MHA DATE: 3/2024

BRIDGE ENGINEER
 PRINT DATE: 8/1/2024
 BRIDGE NO. DISTRICT 1 BRIDGES DRAWING NO. 64156

DATE REVISED	DATE REVISED	FED. RD. DIST. NO.	STATE	JOB NO.	SHEET NO.	TOTAL SHEETS
		6	ARK.	110747	30	30
A3731 - BACKWALL MODIFICATION - 64157						

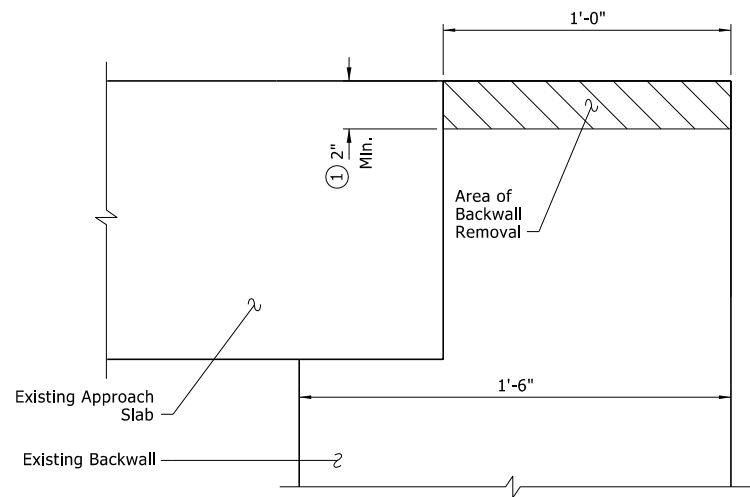

REMOVAL

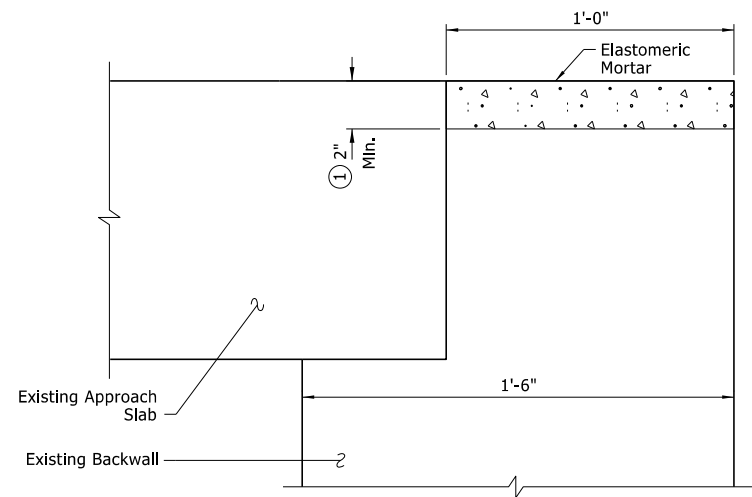

CONSTRUCTION

BACKWALL WITHOUT EXISTING JOINT ARMOR
No Scale

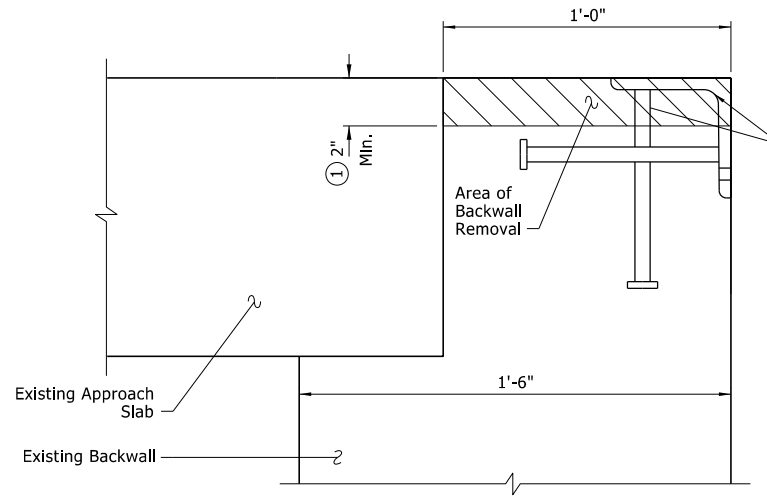

REMOVAL

Portions of existing joint armor to be removed.

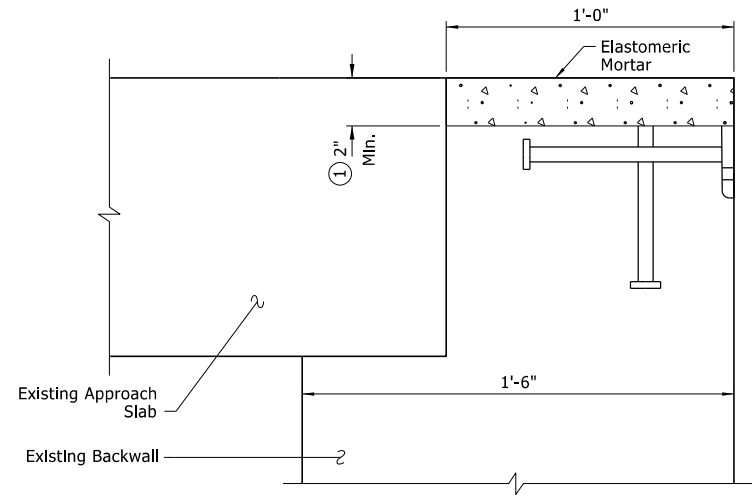

CONSTRUCTION

BACKWALL WITH EXISTING JOINT ARMOR
No Scale

GENERAL NOTES

The proposed work consists of the removal of portions of the existing abutment backwall to sound concrete and replacement with elastomeric mortar in accordance with the details and SP Job 110747 "Bridge Backwall Modification" as well as joint repair. Stage construction phases shall be consistent with the Maintenance of Traffic Details. Backwall repair shall be paid for as "BRIDGE BACKWALL MODIFICATION". Joint repair shall be paid for as "SILICONE JOINT SEALANT".

Dimensions shown are based on original plans and limited field measurements. The Contractor shall check measurements and inspect conditions of concrete and joint armor anchorage and make adjustments to lengths and depths as necessary.

All material removed and not incorporated into the finished property shall become the property of the Contractor and shall be removed and disposed of in accordance with Section 821.

Material used in the repair areas shall be elastomeric mortar in accordance with the requirements of SP Job 110747 "Bridge Backwall Modification".

Transition repairs at edges of repair area in accordance with the manufacturer's recommendations.

Saw cut rough edges of existing armor to create a clean transition.

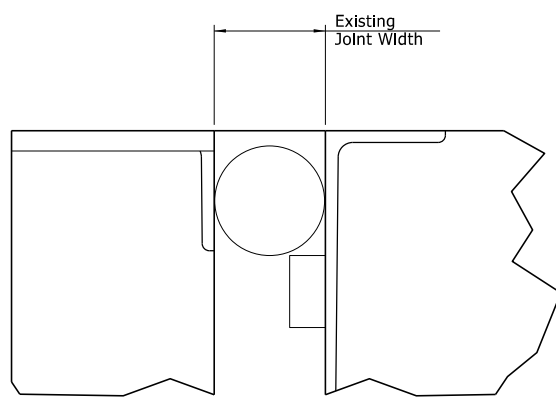

DETAIL A
No Scale
NOTE: See "POURED SILICONE JOINT SEAL DETAILS" on Std. Dwg. No. 55064 for additional information.

① When broken or spalled concrete is greater than dimension shown, chip to sound concrete and sawcut squares/rectangle around damaged area.

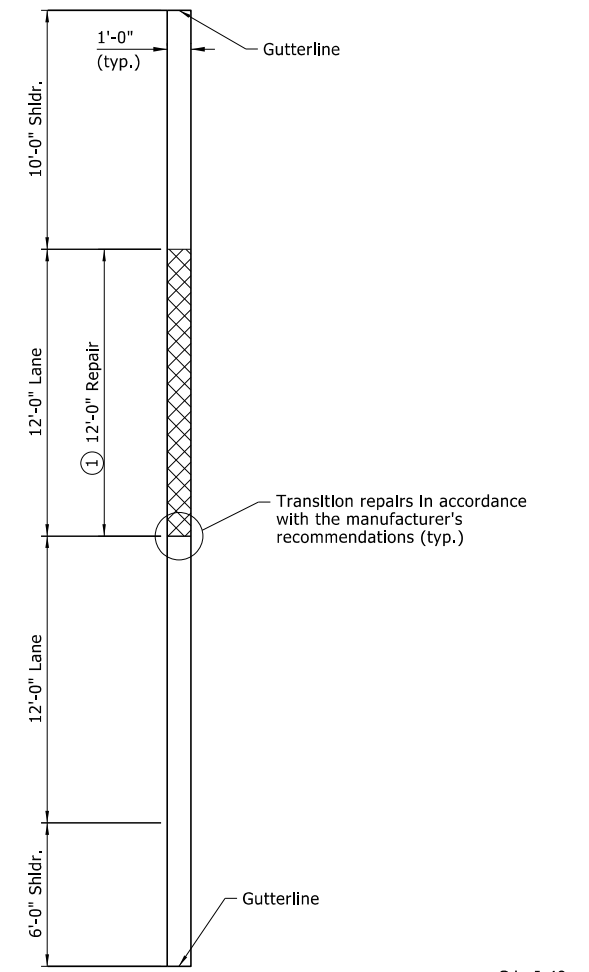

BENT 1

SITE NO. 6 - BRIDGE A3731

¼" = 1'-0"

LEGEND

 Denotes approximate extents of Backwall Modification corresponding with Stage 2 Construction in accordance with Maintenance of Traffic Plans. After backwall repairs are complete, the existing expansion joint shall be repaired in accordance with Std. Dwg. No. 55064. See "DETAIL A" for additional information.

STATE OF ARKANSAS
LISCENSED PROFESSIONAL ENGINEER
No. 20113
ETHAN R. B. BAKER
8-524
BRIDGE ENGINEER
PRINT DATE: 8/1/2024

BACKWALL MODIFICATION DETAILS
ROUTE I-40 SECTION 43
ARKANSAS STATE HIGHWAY COMMISSION

LITTLE ROCK, ARK.
DRAWN BY: LAC DATE: 5/2024 FILENAME: B110747_BW.DGN
CHECKED BY: MKL DATE: 5/2024 SCALE: AS SHOWN
DESIGNED BY: MHA DATE: 3/2024
BRIDGE NO. A3731 DRAWING NO. 64157

Tony Crofton 8/1/2024 16:19:03
 WORKSPACE: c:\user\public\mbp\16-08\50162\B10747_BW.dgn
 REVISED DATE:

DATE REVISED	DATE FILMED	DATE REVISED	DATE FILMED	FED. ROAD DIST. NO.	STATE	FED. AID PROJ. NO.	SHEET NO.	TOTAL SHEETS
				6	ARK.			
				JOB NO.		JOINT REPAIR - 55064		

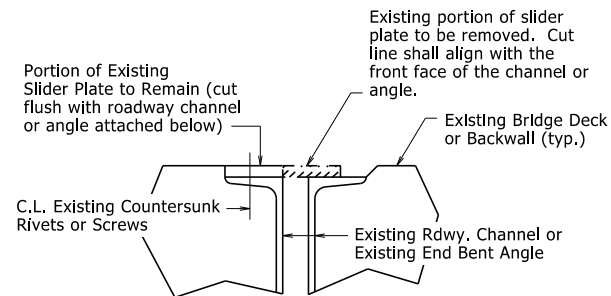

REMOVAL DETAILS AT EXISTING SLIDER PLATE JOINTS

At the direction of the Engineer, the portion of existing slider plate shown shall be removed and replaced with a new plate as shown in "SLIDER PLATE JOINT MODIFICATION". The portion of existing slider plate shall be removed and disposed of in accordance with Section 821. The cut face shall be ground square and flush with the face of the existing angle or channel. Removal and disposal of existing slider plate material will not be paid for directly, but shall be considered subsidiary to the item "Silicone Joint Sealant". Properly functioning slider plates need not be modified.

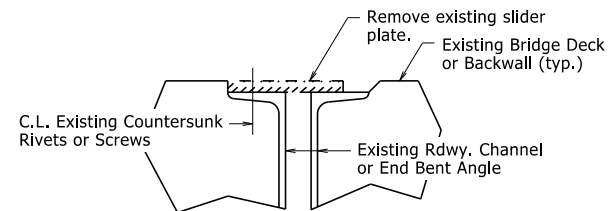

REMOVAL DETAILS AT EXISTING SLIDER PLATE JOINTS WITH GRADE RAISE

The existing slider plate shown shall be removed and replaced with new plates as shown in "JOINT MODIFICATION WITH GRADE RAISE". The existing slider plate shall be removed and disposed of in accordance with Section 821. Removal and disposal of existing slider plate material will not be paid for directly, but shall be considered subsidiary to the item "Silicone Joint Sealant".

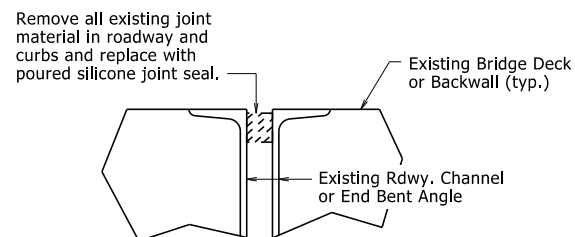

REMOVAL DETAILS AT EXISTING FILLED JOINTS

The existing joint material shall be removed and disposed of in accordance with Section 821. Removal and disposal of existing joint material will not be paid for directly, but shall be considered subsidiary to the item "Silicone Joint Sealant".

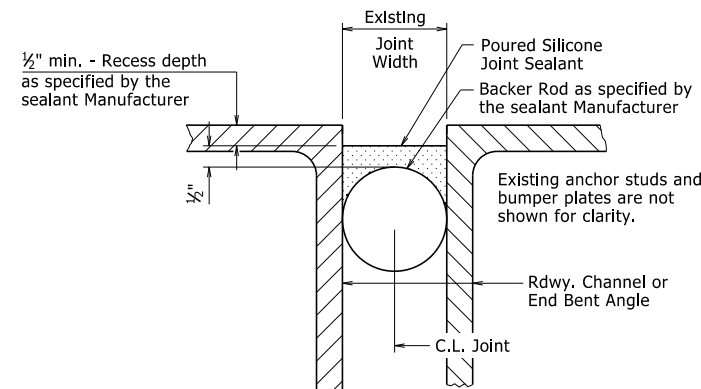

POURED SILICONE JOINT SEAL DETAILS

Existing Joint Seal shall be completely removed, backer rods placed, and Silicone Joint Sealant installed across the entire width of the bridge deck in accordance with these details, Section 809, and the Manufacturer's recommendations. Removal of existing Joint Seal will not be paid for directly, but shall be considered incidental to the item "Silicone Joint Sealant".

Backer rods shall be extended beyond the length of the poured joint in the initial joint repair area so that the two pieces can be properly spliced together prior to installing sealant for the adjacent joint repair. Manufacturer's recommendations shall be followed to prevent sealant leakage during repair work.

Backer rods shall be appropriately sized and set to the depth shown in the Manufacturer's literature based on the joint width at the time of sealing. Except as noted, do not install more backer rod than can be sealed in the same day. The Contractor shall verify separation of the backer rod from the joint material after joint material has set.

Backer rod shall be notched or otherwise fit around any existing seal supports or bumper plates to maintain its proper depth as defined above.

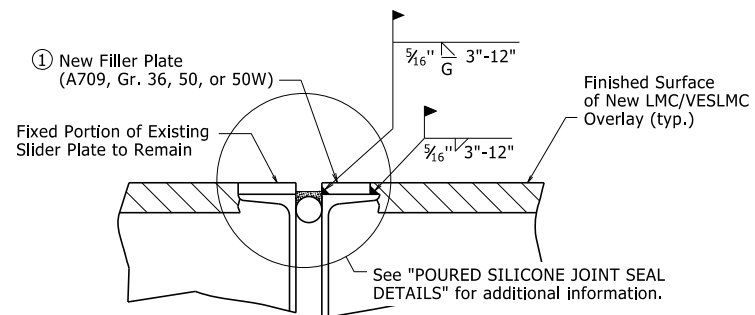

SLIDER PLATE JOINT MODIFICATION

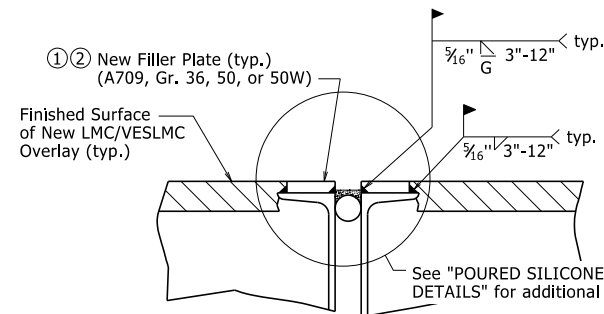

JOINT MODIFICATION WITH GRADE RAISE

1 New field attached plates atop existing roadway channels or angles are required. The plate thickness shall be adjusted as necessary to match surface of finished surface of LMC/VESLMC Overlay and the width shall be 3/8" less than the existing channel flange or angle width to allow for fillet weld as shown.

All new Structural Steel shall be ASTM A709 (Gr. 36, 50, or 50W). The surfaces not in contact with concrete shall be cleaned and painted in accordance with Section 638. Only one coat of paint is required and shall be applied in the fabricator's shop. Grade 50W steel shall not be painted, but shall be cleaned in accordance with Subsection 807.84(e). Structural Steel and Painting will not be paid for directly, but shall be subsidiary to the item "Silicone Joint Sealant".

2 Details shown are for an expansion joint where two bridge units meet. Eliminate filler plate on backwall and proceed with backwall repair in accordance with "BACKWALL REPAIR REMOVAL DETAIL" and "BACKWALL REPAIR INSTALLATION DETAIL" at end bents for bridge decks with grade raise, see Standard Drawing Number 55065.

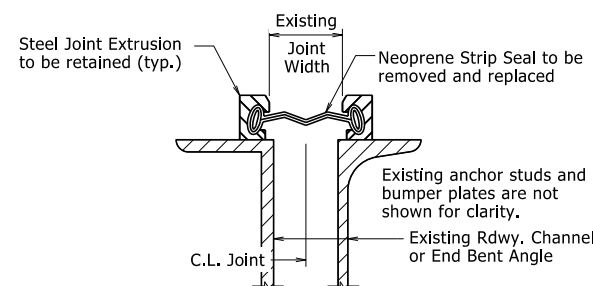

STRIP SEAL JOINT DETAILS

Existing neoprene strip seal joint material shall be completely removed and new neoprene strip seal joint material shall be installed across the entire width of the steel extrusions in accordance with these details, Section 809, and the Manufacturer's recommendations. Prior to installing the new joint material, the Contractor shall clean the steel extrusion at the Engineer's direction and in accordance with the new strip seal joint material Manufacturer's recommendations.

Removal and replacement of the existing neoprene strip seal joint material will require the removal of the parapet slider plates, where present. Parapet slider plates removed for this work shall be reinstalled after installation of the new neoprene strip seal joint material.

The new neoprene strip seal joint material shall provide a movement rating of four inches. The repaired expansion joint shall be capable of sealing the deck surface and parapet area to prevent moisture and other contaminants from descending through the joint.

All work and material associated with removing the existing joint material, cleaning the extrusions, removal and reinstallation of parapet slider plates, and installation of new joint material shall be paid for under the item "Modification of Existing Bridge Structure (Bridge No. _)".

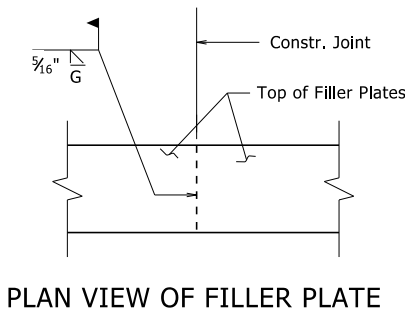

PLAN VIEW OF FILLER PLATE

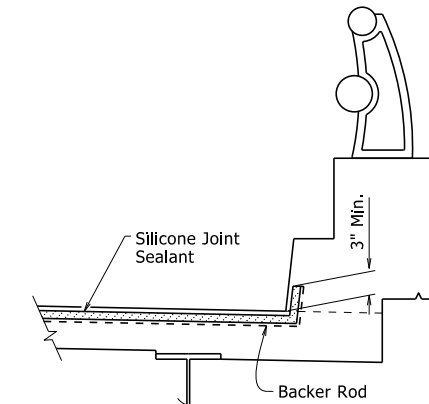

SILICONE JOINT SEAL PLACEMENT AT CURB

Vertical joints may require forming. The clearance from deck surface to joint material shall be maintained.

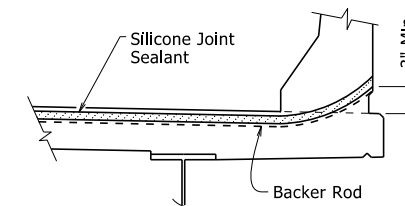

SILICONE JOINT SEAL PLACEMENT AT RAIL

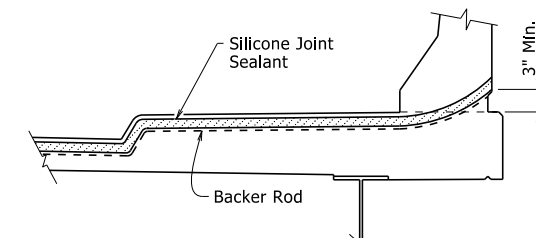

SILICONE JOINT SEAL PLACEMENT AT SIDEWALK

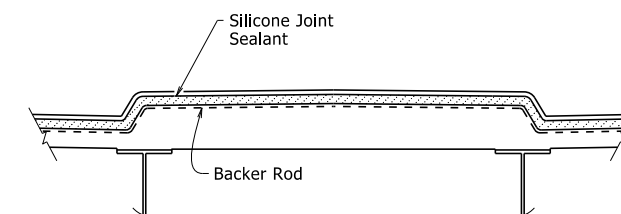

SILICONE JOINT SEAL PLACEMENT AT MEDIAN

This document was originally issued and sealed by Charles R. Ellis, PE No. 9235, on November 7, 2019. This copy is not a signed and sealed document.

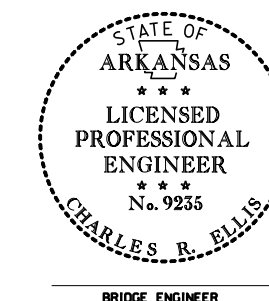

STANDARD DETAILS FOR JOINT REPAIRS & MODIFICATIONS
ARKANSAS STATE HIGHWAY COMMISSION

LITTLE ROCK, ARK.

DRAWN BY: KWY DATE: 11/7/2019 FILENAME: b55064.dgn
CHECKED BY: SWP DATE: 11/7/2019 SCALE: None
DESIGNED BY: STD. DATE: -----

DRAWING NO. 55064

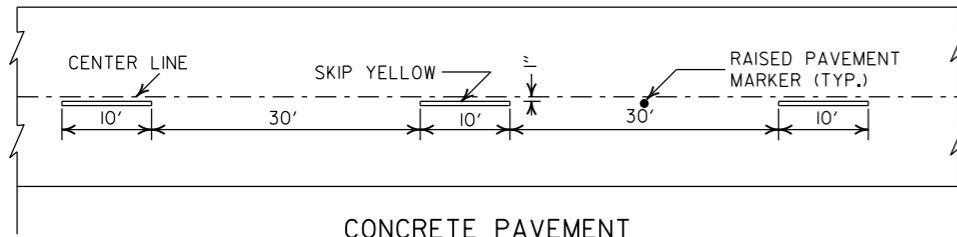

CONCRETE PAVEMENT

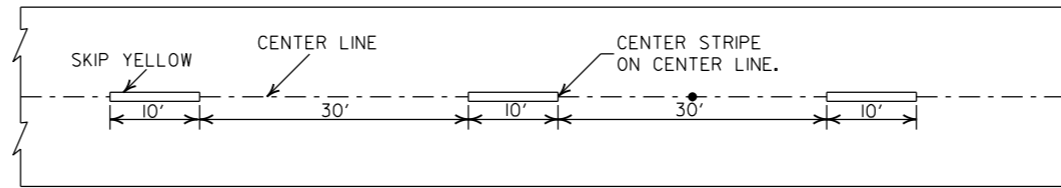

ASPHALT PAVEMENT

BROKEN LINE STRIPING

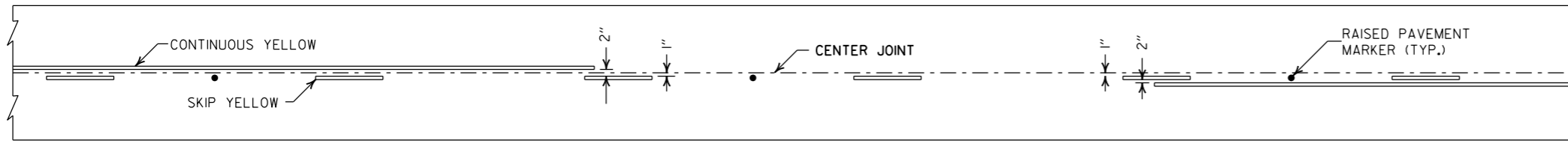

SOLID LINE STRIPING ON CONCRETE PAVEMENT

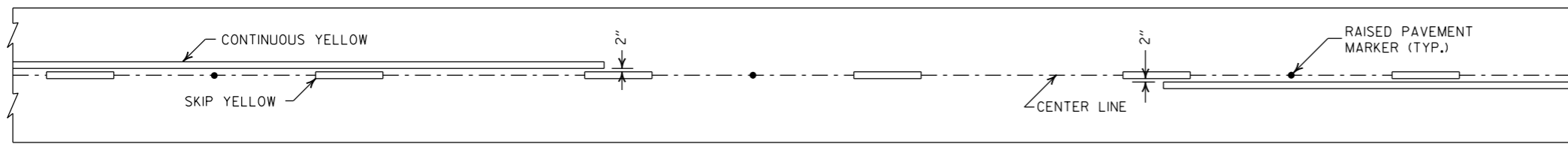

SOLID LINE STRIPING ON ASPHALT PAVEMENT

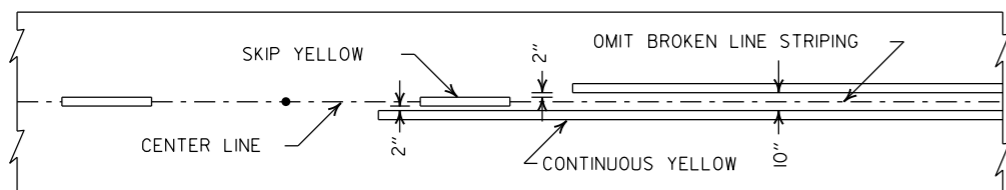

ASPHALT PAVEMENT

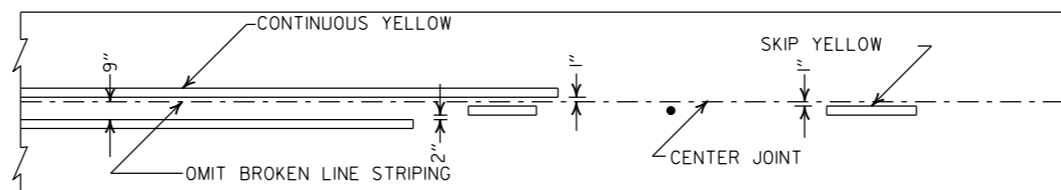

CONCRETE PAVEMENT

STRIPING AT ADJACENT NO PASSING LANES

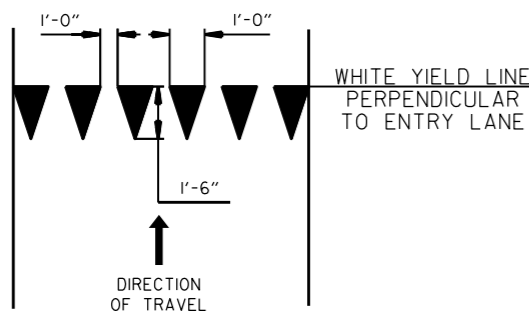

YIELD LINE DETAIL

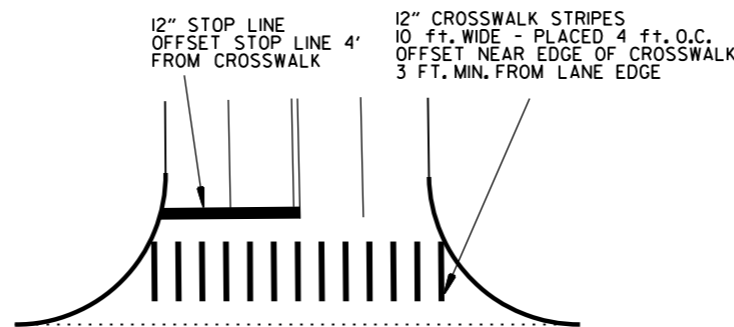

CROSSWALK AND STOP LINE DETAILS

- NOTES:
1. REFER TO THE STRIPING DETAILS FOR PAVEMENT MARKING LINE WIDTHS.
 2. THIS DRAWING SHALL BE USED IN CONJUNCTION WITH THE LATEST REVISED ADDITION OF THE "MANUAL ON UNIFORM TRAFFIC CONTROL DEVICES."
 3. RAISED PAVEMENT MARKERS SHALL BE PLACED ON AN 80 FEET SPACING UNLESS OTHERWISE SHOWN IN THE PLANS.

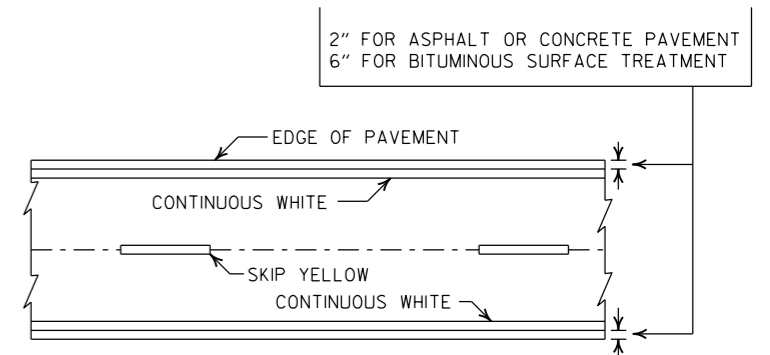

PAVEMENT EDGE LINE MARKING

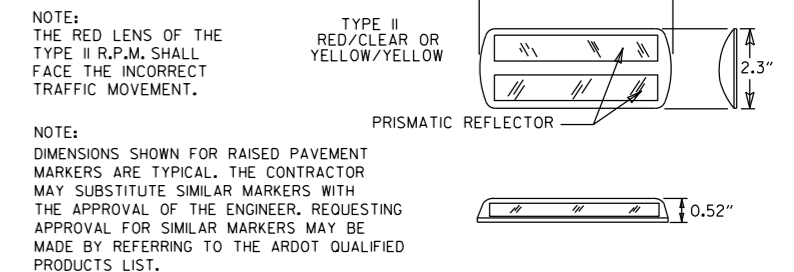

DETAIL OF STANDARD RAISED PAVEMENT MARKERS

DATE	REVISION	FILMED
2-27-20	REVISED STOP LINE DETAILS	
6-1-17	ADDED YIELD LINE DETAIL	
5-12-16	REVISED LINE WIDTHS, SPACING, & NOTES	
9-12-13	REVISED DETAIL OF STANDARD RAISED PAVEMENT MARKERS	
11-17-10	REVISED GENERAL NOTES & REMOVED PLOWABLE PVMT MRKRS	
11-18-04	REVISED NOTE 2 & GENERAL NOTES	
8-22-02	ADDED CROSSWALK & STOPBAR DTL.	
7-02-98	ADDED DETAILS OF STD. RAISED PAV'T. MARKERS	
4-26-96	REV. NOTES 3&4; ADDED R.P.M.	
9-30-80	DRAWN	1-9-30-80

ARKANSAS STATE HIGHWAY COMMISSION

PAVEMENT MARKING DETAILS

STANDARD DRAWING PM-1

ENTRANCE RAMP
12" WHITE = 370 LIN. FT.
RAISED PAVEMENT MARKERS TYPE II (WHITE/RED) = 38 EACH

EXIT RAMP
6" WHITE = 280 LIN. FT.
12" WHITE = 815 LIN. FT.
RAISED PAVEMENT MARKERS TYPE II (WHITE/RED) = 38 EACH
RAISED PAVEMENT MARKERS TYPE II (WHITE/RED) = 48 EACH

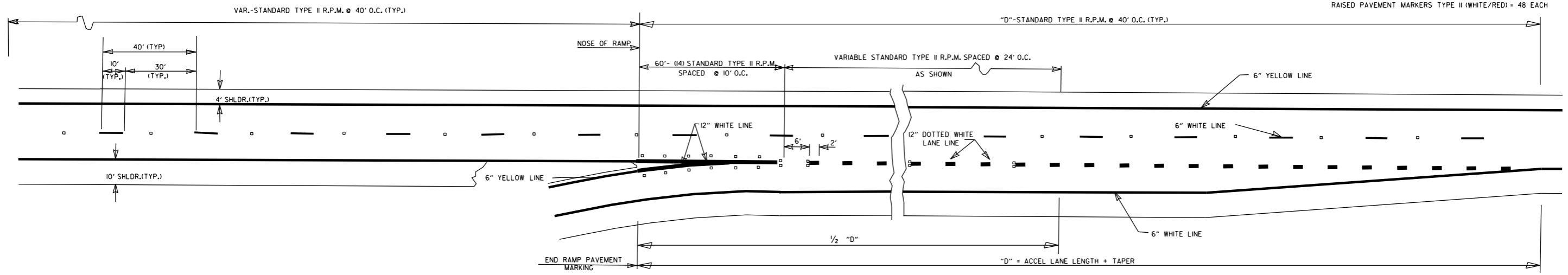

ENTRANCE RAMPS

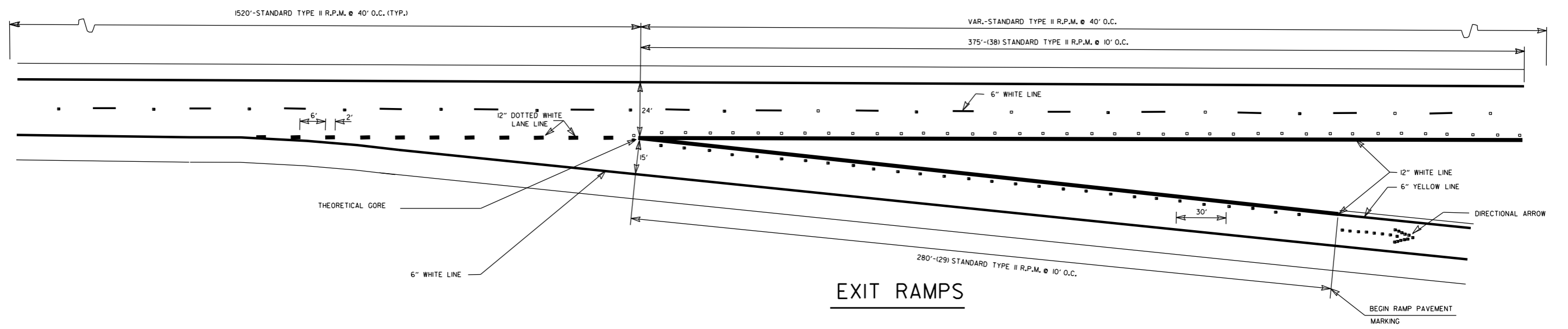

EXIT RAMPS

GENERAL NOTES:
THIS DRAWING SHOULD BE CONSIDERED AS TYPICAL ONLY AND THE FINAL LOCATION OF THE STRIPING AND PAVEMENT MARKERS SHALL BE DETERMINED BY THE ENGINEER.

THIS DRAWING SHOULD BE USED IN CONJUNCTION WITH THE "MANUAL ON UNIFORM TRAFFIC CONTROL DEVICES", LATEST REVISION.

NOTE:
DIMENSIONS SHOWN FOR RAISED PAVEMENT MARKERS ARE TYPICAL. THE CONTRACTOR MAY SUBSTITUTE SIMILAR MARKERS WITH THE APPROVAL OF THE ENGINEER. REQUESTING APPROVAL FOR SIMILAR MARKERS MAY BE MADE BY REFERRING TO THE ARDOT QUALIFIED PRODUCTS LIST.

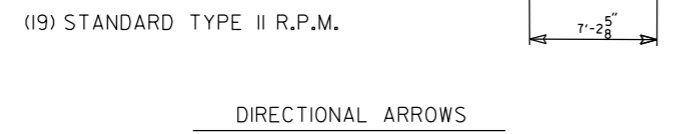
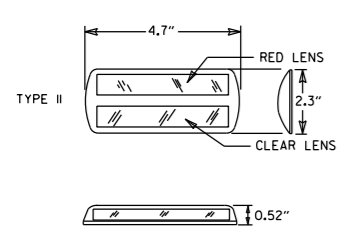











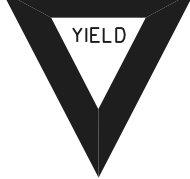





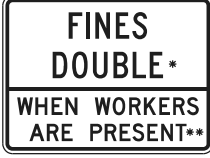

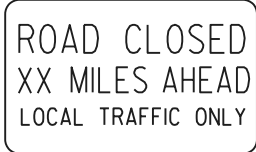

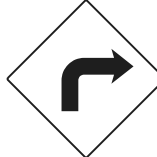







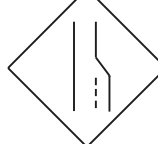











DATE	REVISION	FILMED
05-14-20	REMOVED CROSSHATCH MARKINGS ON EXIT RAMPS	
11-07-19	REVISED DOTTED PAV'T MARKINGS; ADDED CROSSHATCH MARKINGS ON EXIT RAMPS	
12-8-16	REVISED RAISED PAV'T MARKERS FOR 80' SPACING; REVISED WIDTH OF STRIPING	
9-12-13	REVISED DETAIL OF STANDARD RAISED PAVEMENT MARKERS	
7-26-12	REVISED RPM NOTATION	
12-15-11	REVISED RPMs ACCORDING TO LATEST POLICY	
11-17-10	REMOVED PLOWABLE PAVEMENT MARKERS	
6-3-10	REVISED PER 2009 MUTCD	
11-18-04	REVISED NOTES	
8-22-02	ADDED & REVISED NOTES; REV. ENTRANCE & EXIT RAMPS	
5-18-00	REMOVED HASHMARKS	
7-02-98	CHANGED TYPES TO ROMAN NUMERALS	
4-26-96	ADDED DIMENSIONS & QUANTITIES; REVISED LANE WIDTH ON EXIT RAMP	
2-2-95	PLACED IN USE	2-2-95
		FILMED

ARKANSAS STATE HIGHWAY COMMISSION

**PAVEMENT MARKING DETAILS
ON
ACCESS CONTROLLED ROADWAYS**

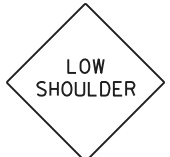
STANDARD DRAWING PM-2

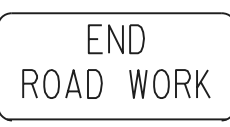
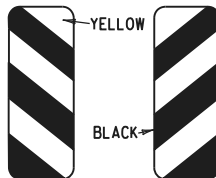
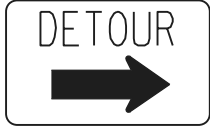
NOTE:
THE RED LENS OF THE TYPE II R.P.M. SHALL FACE THE INCORRECT TRAFFIC MOVEMENT.

<p>RI-1</p>  <p>STANDARD 30"x30" EXPRESSWAY 36"x36" SPECIAL 48"x48"</p>	<p>RI-2</p>  <p>STD. 36"x36"x36" EXPWY. 48"x48"x48" FWY. 60"x60"x60"</p>	<p>R2-1</p>  <p>STD. 24"x30" EXPWY. 36"x48" FWY. 48"x60"</p>	<p>W3-5</p>  <p>STD. 36"x36" EXPWY. 48"x48" FWY. 48"x48"</p>	<p>W3-5a</p>  <p>STD. 36"x36" EXPWY. 48"x48" FWY. 48"x48"</p>	<p>R4-1</p>  <p>STD. 24"x30" EXPWY. 36"x48" FWY. 48"x60"</p>	<p>R4-2</p>  <p>STD. 24"x30" EXPWY. 36"x48" FWY. 48"x60"</p>	<p>R2-6aP</p>  <p>48"x36" *USE 6" C LETTERS **USE 4" D LETTERS</p>
<p>R5-1</p>  <p>STD. 30"x30" EXPWY. 36"x36" SPECIAL 48"x48"</p>	<p>R11-2</p>  <p>48"x30"</p>	<p>R11-3A</p>  <p>60"x30"</p>	<p>R11-4</p>  <p>60"x30"</p>	<p>W21-5a</p>  <p>STD. 36"x36" FWY. 48"x48"</p>	<p>WI-1</p>  <p>STD. 36"x36" FWY. 48"x48"</p>	<p>WI-2</p>  <p>STD. 36"x36" FWY. 48"x48"</p>	<p>R2-II</p>  <p>36"x48"</p>
<p>WI-3</p>  <p>STD. 48"x48"</p>	<p>WI-4</p>  <p>STD. 48"x48"</p>	<p>WI-6</p>  <p>STD. 48"x24" SPECIAL 60"x30"</p>	<p>WI-8</p>  <p>STD. 18"x24" SPECIAL 24"x30" EXPWY. 30"x36" FWY. 36"x48"</p>	<p>W3-1</p>  <p>STD. 36"x36" SPECIAL 48"x48"</p>	<p>W3-2</p>  <p>STD. 36"x36" SPECIAL 48"x48"</p>	<p>W4-2</p>  <p>STD. 36"x36" FWY. 48"x48"</p>	<p>R56-1</p>  <p>STD. 18"x18"</p>
<p>W5-1</p>  <p>STD. 36"x36" SPECIAL 48"x48"</p>	<p>W6-3</p>  <p>EXPWY. 36"x36" SPECIAL 48"x48"</p>	<p>W8-7</p>  <p>EXPWY. 36"x36" FWY. 48"x48"</p>	<p>W9-2</p>  <p>STD. 36"x36" FWY. 48"x48"</p>	<p>W13-1</p>  <p>STD. 24"x24"</p>	<p>W20-1</p>  <p>STD. 48"x48"</p>	<p>W20-2</p>  <p>STD. 48"x48"</p>	<p>W20-3</p>  <p>STD. 48"x48"</p>
<p>W20-4</p>  <p>STD. 48"x48"</p>	<p>W20-5</p>  <p>STD. 48"x48"</p>	<p>W20-7a</p>  <p>18" 500 FEET W6-2 24"</p> <p>STD. 36"x36" FWY. 48"x48"</p>	<p>W21-2</p>  <p>STD. 30"x30" SPECIAL 36"x36"</p>	<p>W21-5</p>  <p>STD. 30"x30" SPECIAL 36"x36"</p>	<p>W24-1</p>  <p>STD. 36"x36"</p>	<p>WI-4b</p>  <p>STD. 48"x48"</p>	
<p>W8-II</p>  <p>STD. 36"x36" FWY. 48"x48"</p>	<p>W8-9</p>  <p>STD. 36"x36" FWY. 48"x48"</p>	<p>G20-1</p>  <p>60"x24"</p>	<p>G20-2</p>  <p>48"x24"</p>	<p>OM-3L OM-3R</p>  <p>12"x36"</p>	<p>M4-9</p>  <p>STD. 30"x24" SPECIAL 48"x36" SPECIAL 60"x48"</p>	<p>M4-10</p>  <p>48"x18"</p>	

GENERAL NOTES:

- ALL TRAFFIC CONTROL DEVICES USED ON ROAD CONSTRUCTION SHALL CONFORM TO THE MANUAL ON UNIFORM TRAFFIC CONTROL DEVICES, LATEST EDITION, AND TO THE STANDARD HIGHWAY SIGNS, LATEST EDITION, OR AS APPROVED BY THE FEDERAL HIGHWAY ADMINISTRATION.
- TRAFFIC CONTROL DEVICES SHALL BE SET UP JUST BEFORE THE START OF CONSTRUCTION OPERATIONS AND SHALL BE PROPERLY MAINTAINED DURING THE TIME SUCH CONDITIONS EXIST. THEY SHALL REMAIN IN PLACE ONLY AS LONG AS NEEDED AND REMOVED THEREAFTER.
- EXISTING SIGNS AND CONSTRUCTION SIGNS SHALL BE KEPT IN PROPER POSITION, AND BE CLEAN AND LEGIBLE AT ALL TIMES. SIGNS THAT DO NOT APPLY TO EXISTING CONDITIONS SHALL BE REMOVED. SIGNS THAT ARE DAMAGED, DEFACED, OR THAT ACCUMULATE DIRT DURING CONSTRUCTION SHALL BE CLEANED, REPAIRED, OR REPLACED.
- SIGNS ARE USUALLY MOUNTED ON A SINGLE POST, ALTHOUGH THOSE WIDER THAN 36" OR LARGER THAN 10 SO. FT. SHALL BE MOUNTED ON TWO POSTS OR ABOVE A TYPE III BARRICADE.
- SIGN POSTS DIRECT BURIED IN SOIL SHALL BE 2 LB. MINIMUM CHANNEL POST OR 4"x4" WOOD POSTS. CHANNEL POSTS SHALL BE PAINTED GREEN. WOOD POSTS SHALL BE PAINTED WHITE. ALL POSTS SHALL BE NEATLY CONSTRUCTED, AND SHALL BE REPLUMBED, CLEANED, OR REPAIRED AS NEEDED FOR THE DURATION OF THE JOB. THERE SHALL NOT BE MORE THAN 2 POSTS IN A 7' PATH FOR WOOD OR CHANNEL POSTS. ANY CHANNEL POST SPLICE SHALL BE IN ACCORDANCE WITH STANDARD DRAWING TC-3.
- POST MOUNTED SIGNS IN RURAL AREAS SHALL BE CONSTRUCTED WITH THE NEAR EDGE OF THE SIGN FROM 6 TO 12 FEET FROM THE PAVEMENT EDGE. SIGNS IN URBAN AREAS AND BARRICADE MOUNTED SIGNS SHALL BE MOUNTED A MINIMUM OF 2 FEET FROM THE PAVEMENT EDGE.
- ALL POST AND BARRICADE MOUNTED SIGNS MOUNTED IN URBAN AREAS SHALL BE MOUNTED A MINIMUM DISTANCE OF 7' FROM THE BOTTOM OF THE SIGN TO THE ROADWAY SURFACE. ALL POST AND BARRICADE MOUNTED SIGNS MOUNTED IN RURAL AREAS SHALL BE MOUNTED A MINIMUM DISTANCE OF 7' FROM THE BOTTOM OF THE SIGN TO THE ROADWAY SURFACE, EXCEPT A MINIMUM OF 6' SHALL BE USED WHEN MOUNTING AN ADVISORY SIGN BELOW A WARNING SIGN. TEMPORARY SIGNS MAY BE MOUNTED ON PORTABLE SUPPORTS FOR INTERMEDIATE TERM STATIONARY WORK CONDITIONS. THE SIGNS MINIMUM MOUNTING HEIGHT SHALL BE 5'. RETROREFLECTIVE DEVICES SHALL BE USED. TEMPORARY SIGNS MAY BE MOUNTED ON PORTABLE SUPPORTS FOR SHORT-TERM, SHORT DURATION, AND MOBILE CONDITIONS. THEY SHALL BE NO LESS THAN ONE (1) FOOT ABOVE THE TRAVELED WAY. LONG-TERM STATIONARY SIGNS SHALL BE DIRECT BURIED IN SOIL, UNLESS CONDITIONS NECESSITATE THE USE OF PORTABLE SIGNS, OR AS APPROVED BY THE ENGINEER. CONCRETE PADS, CONCRETE OR ROCK BALLAST, OR OTHER SOLID MATERIALS SHALL NOT BE UTILIZED WITH PORTABLE SIGN SUPPORTS.
- FLAGGERS SHALL USE REFLECTORIZED STOP-SLOW PADDLES. FLAGS MAY BE USED ONLY FOR EMERGENCY SITUATIONS.
- MOST OF THE SIGNS SHOWN ARE ORIENTED TO THE RIGHT. HOWEVER, THIS DOES NOT PRECLUDE THE USE OF MIRROR IMAGES OF THESE SIGNS WHERE THE REVERSE ORIENTATION MIGHT BETTER CONVEY TO MOTORISTS THE PROPER DIRECTION OF MOVEMENT.
- R2-6aP PLAQUES SHALL BE MOUNTED BELOW AN APPLICABLE ADVANCE WARNING SIGN THAT IS LOCATED AT LEAST 1500' BUT NOT MORE THAN 1MILE IN ADVANCE OF THE WORK ZONE. IF A SPEED LIMIT REDUCTION IS IN EFFECT, THE PLAQUE SHALL BE PLACED A MINIMUM OF 500' IN ADVANCE OF THE W3-5 "REDUCED SPEED AHEAD" SIGN. R2-II SIGNS SHALL BE INSTALLED AT OR NEAR THE DOWNSTREAM END OF THE WORK ZONE. SEE STANDARD DRAWINGS TC-2, TC-3, AND TC-6 FOR TYPICAL PLACEMENT LOCATIONS.

*NOTE: SUPPORTS FOR SIGNS, BARRICADES, AND VERTICAL PANELS THAT ARE DIFFERENT FROM THE REQUIREMENTS SHOWN IN NOTES 4 & 5, BUT MEET THE REQUIREMENTS OF MANUAL FOR ASSESSING SAFETY HARDWARE (MASH), WILL BE ACCEPTED. COMPLIANCE WITH THE REQUIREMENTS OF MANUAL FOR ASSESSING SAFETY HARDWARE (MASH) IS REQUIRED FOR ALL PROJECTS.

		<p>ARKANSAS STATE HIGHWAY COMMISSION</p>	
<p>STANDARD TRAFFIC CONTROLS FOR HIGHWAY CONSTRUCTION</p>			
<p>REPLACED R55-1 WITH R2-6aP, ADDED R2-11 & REVISED NOTE 10</p>	<p>REVISED FOR MASH</p>	<p>DELETED RSP-1 & ADDED W21-5a</p>	<p>REVISED REDUCED SPEED SIGN TO SHOW NEXT SIX MILES</p>
<p>08-14-25</p>	<p>11-07-19</p>	<p>04-13-17</p>	<p>09-02-15</p>
<p>DATE</p>	<p>REV</p>	<p>DATE</p>	<p>REV</p>
<p>08-14-2025</p>	<p>STANDARD DRAWING</p>	<p>TC-1</p>	<p>DESCRIPTION</p>

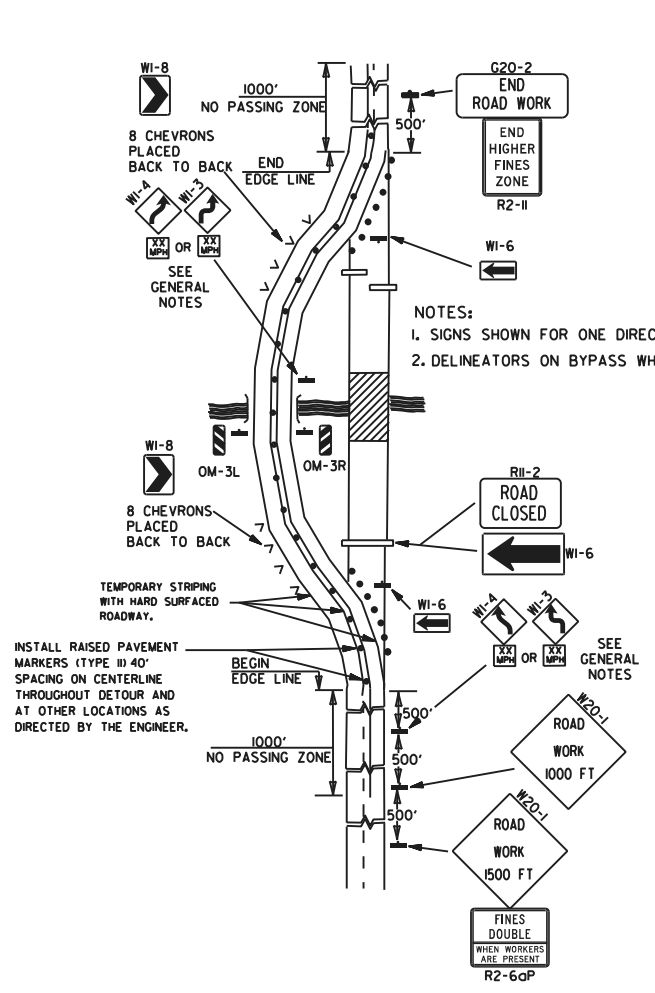

(A) TYPICAL APPLICATION OF TRAFFIC CONTROL DEVICES ON A 2-LANE HIGHWAY WHERE THE ENTIRE ROADWAY IS CLOSED AND A BYPASS DETOUR IS PROVIDED.

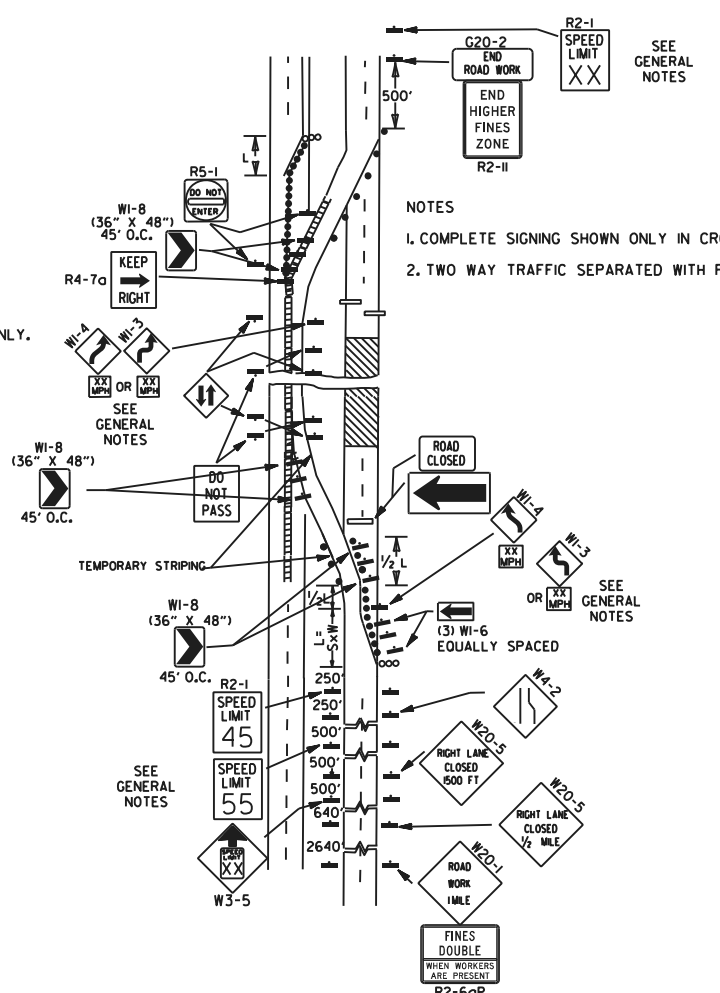

(B) TYPICAL APPLICATION - 4-LANE DIVIDED ROADWAY WHERE ONE ROADWAY IS CLOSED.

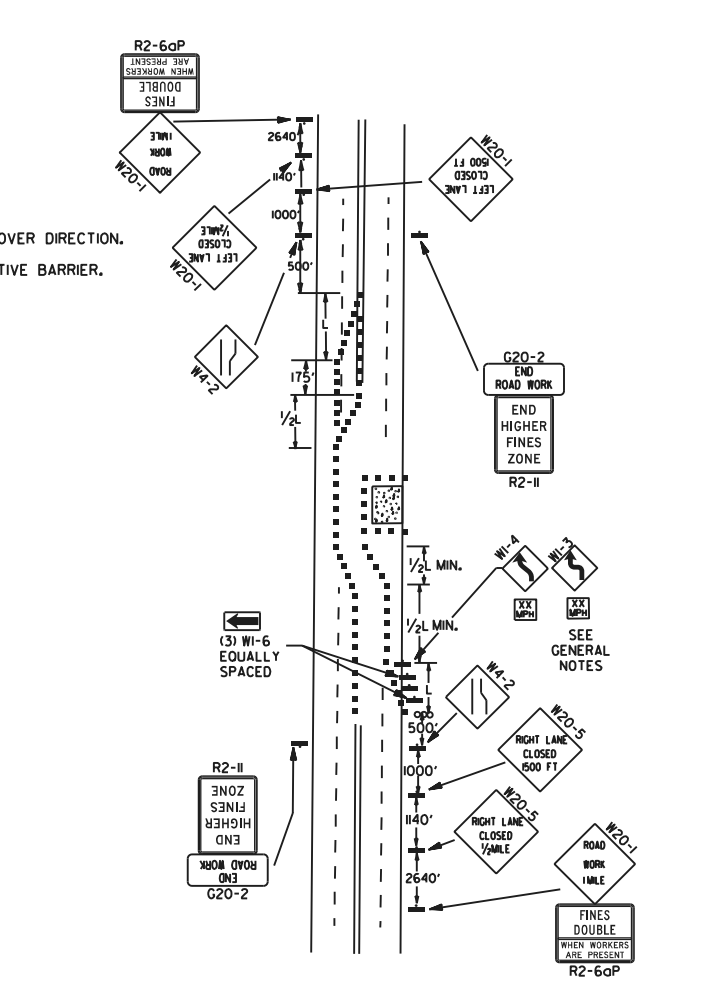

(C) TYPICAL APPLICATION - 4-LANE UNDIVIDED ROADWAY WHERE HALF OF THE ROADWAY IS CLOSED.

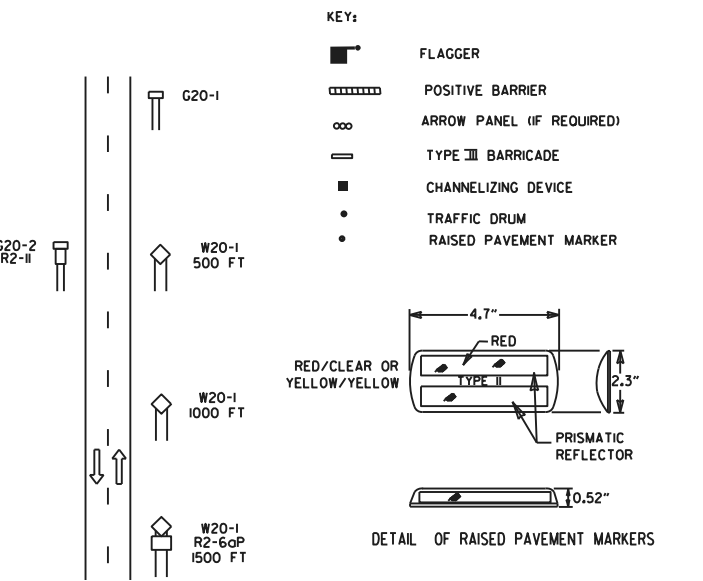

KEY:

- FLAGGER
- POSITIVE BARRIER
- ARROW PANEL (IF REQUIRED)
- TYPE III BARRICADE
- CHANNELIZING DEVICE
- TRAFFIC DRUM
- RAISED PAVEMENT MARKER

RED/CLEAR OR YELLOW/YELLOW

PRISMATIC REFLECTOR

DETAIL OF RAISED PAVEMENT MARKERS

TYPICAL ADVANCE WARNING SIGN PLACEMENT

TAPER FORMULAE:

L = SXW FOR SPEEDS OF 45MPH OR MORE.

$L = \frac{WS}{60}$ FOR SPEEDS OF 40MPH OR LESS.

WHERE:

L = MINIMUM LENGTH OF TAPER.

S = NUMERICAL VALUE OF POSTED SPEED LIMIT PRIOR TO WORK OR 85TH PERCENTILE SPEED.

W = WIDTH OF OFFSET.

- GENERAL NOTES:
- THE MAINTENANCE DIVISION SHALL CONDUCT A BALL BANK STUDY TO DETERMINE THE ADVISORY SPEED LIMIT PRIOR TO OPENING TO TRAFFIC. THE ADVISORY SPEED WILL BE POSTED ON W1-3 OR W1-4 CURVE WARNING SIGNS. USE W1-4 WHEN SPEED IS GREATER THAN 30MPH AND W1-3 WHEN 30MPH OR LESS.
 - WHEN THE EXISTING SPEED LIMIT IS 55MPH AND THE PLANS REQUIRE A SPEED LIMIT OF 45MPH, THE R2-1(55) SHALL BE OMITTED AND THE W3-5 SHALL BE INSTALLED AT THAT LOCATION. ADDITIONAL R2-1(45MPH) SPEED LIMIT SIGNS SHALL BE INSTALLED AT A MAXIMUM OF 1/2 MILE INTERVALS. AT THE END OF THE WORK AREA A R2-1(XX) SHALL BE INSTALLED TO MATCH ORIGINAL SPEED LIMIT.
 - WHEN THE EXISTING SPEED LIMIT IS 65MPH AND THE PLANS REQUIRE A SPEED LIMIT OF 55MPH, THE R2-1(65) SHALL BE OMITTED. ADDITIONAL R2-1(55MPH) SPEED LIMIT SIGNS SHALL BE INSTALLED AT A MAXIMUM OF 1/2 MILE INTERVALS. AT THE END OF THE WORK AREA A R2-1(XX) SHALL BE INSTALLED TO MATCH ORIGINAL SPEED LIMIT.
 - THE MAXIMUM SPACING BETWEEN CHANNELIZING DEVICES IN A TAPER SHOULD BE APPROXIMATELY EQUAL IN FEET TO THE SPEED LIMIT. BEYOND THE TAPER, MAXIMUM SPACING SHALL BE TWO TIMES THE SPEED LIMIT, OR AS DIRECTED BY THE ENGINEER.
 - WARNING LIGHTS AND/OR FLAGS MAY BE MOUNTED TO SIGNS OR CHANNELIZING DEVICES AT NIGHT AS NEEDED.
 - PAVEMENT MARKINGS NO LONGER APPLICABLE WHICH MIGHT CREATE CONFUSION IN THE MINDS OF VEHICLE OPERATORS SHALL BE REMOVED OR OBLITERATED AS SOON AS PRACTICABLE.
 - TRAILER MOUNTED DEVICES SUCH AS ARROW PANELS AND PORTABLE CHANGEABLE MESSAGE SIGNS SHALL BE DELINEATED BY AFFIXING CONSPICUITY MATERIAL IN A CONTINUOUS LINE ON THE FACE OF THE TRAILER. WHEN PLACED ON OR ADJACENT TO THE SHOULDER AND NOT BEHIND A POSITIVE BARRIER, THESE DEVICES SHALL BE DELINEATED BY PLACING FIVE (5) TRAFFIC DRUMS, EQUALLY SPACED ALONG THE TRAFFIC SIDE OF THE DEVICE. PAYMENT FOR TRAFFIC DRUMS SHALL BE CONSIDERED INCLUDED IN THE PRICE BID FOR VARIOUS TRAILER MOUNTED DEVICES.
 - DIMENSIONS SHOWN FOR RAISED PAVEMENT MARKERS ARE TYPICAL. THE CONTRACTOR MAY SUBSTITUTE SIMILAR MARKERS WITH THE APPROVAL OF THE ENGINEER. REQUESTING APPROVAL FOR SIMILAR MARKERS MAY BE MADE BY REFERRING TO THE ARDOT QUALIFIED PRODUCTS LIST.
 - ALL TRAILER MOUNTED DEVICES SUCH AS ARROW PANELS AND PORTABLE CHANGEABLE MESSAGE SIGNS SHALL MEET THE REQUIREMENTS OF THE MANUAL FOR ASSESSING SAFETY HARDWARE (MASH).

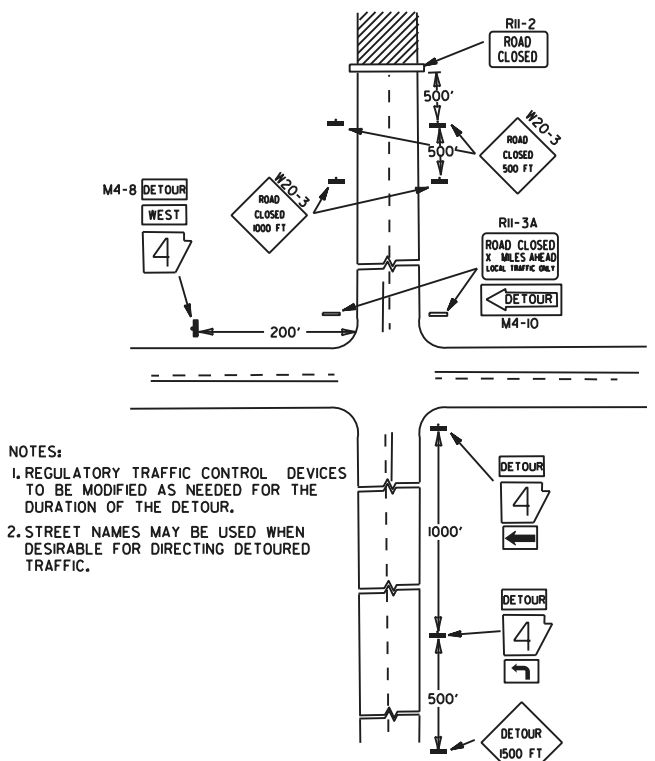

(D) TYPICAL APPLICATION - ROADWAY CLOSED BEYOND DETOUR POINT.

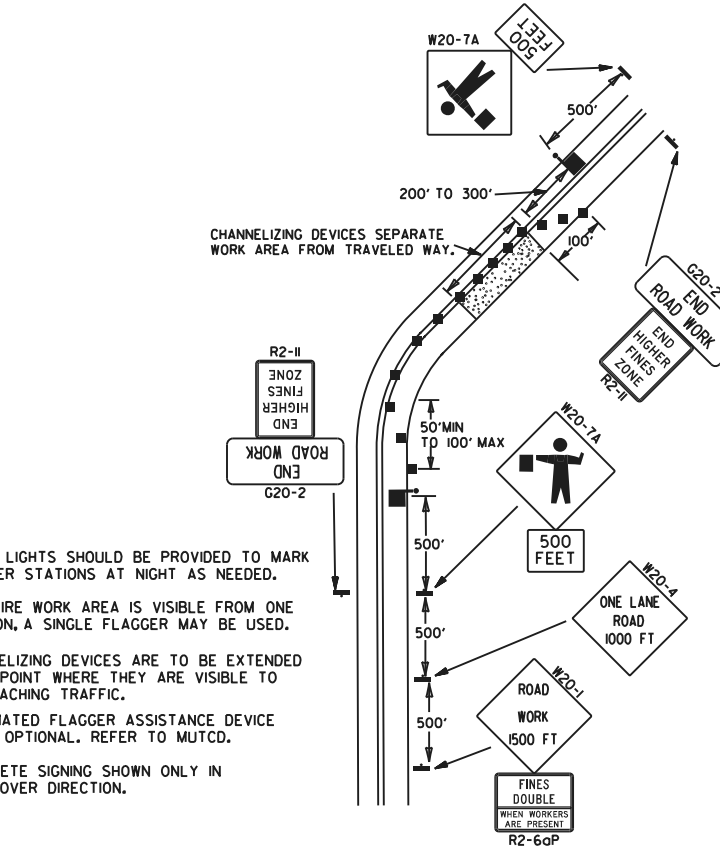

(E) TYPICAL APPLICATION OF TRAFFIC CONTROL DEVICES ON 2-LANE HIGHWAY WHERE ONE LANE IS CLOSED AND FLAGGING IS PROVIDED.

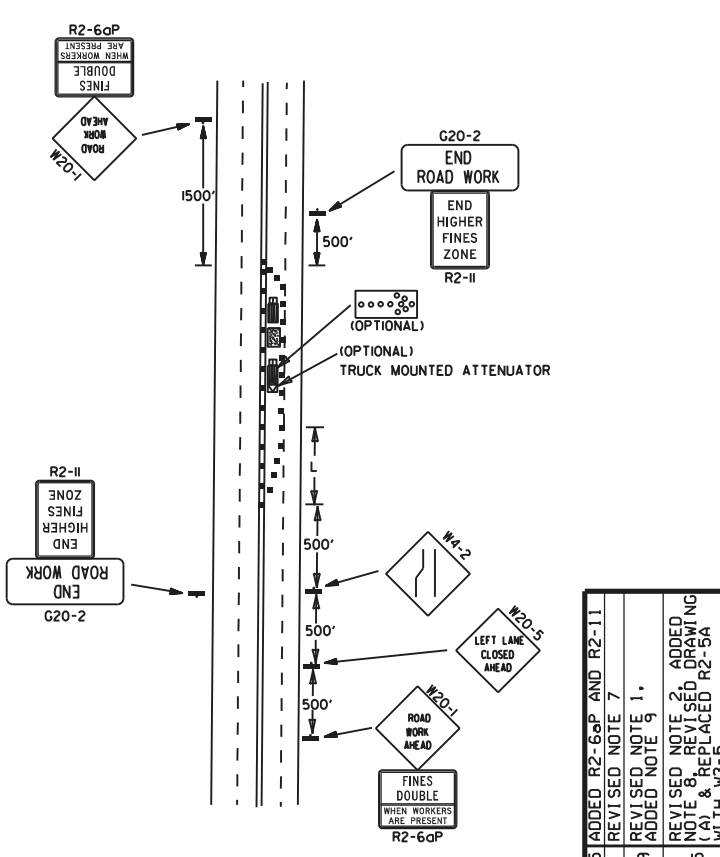

(F) TYPICAL APPLICATION - 4-LANE UNDIVIDED ROADWAY WITH INSIDE LANE CLOSED.

DATE	REV	DESCRIPTION
08-14-25	ADDED R2-6aP AND R2-11	
05-20-21	REVISED NOTE 7	
11-07-19	ADDED NOTE 9	
09-02-15	REVISED NOTE 2 ADDED NOTE 8 - REVISED DRAWING (A) & REPLACED R2-5A WITH W3-5	
09-12-13	REVISED DETAIL OF MARKINGS	

AR DOT ARKANSAS DEPARTMENT OF TRANSPORTATION		ARKANSAS STATE HIGHWAY COMMISSION	
STANDARD TRAFFIC CONTROLS FOR HIGHWAY CONSTRUCTION			
DATE EFFECTIVE	STANDARD DRAWING	TC-2	
08-14-2025			

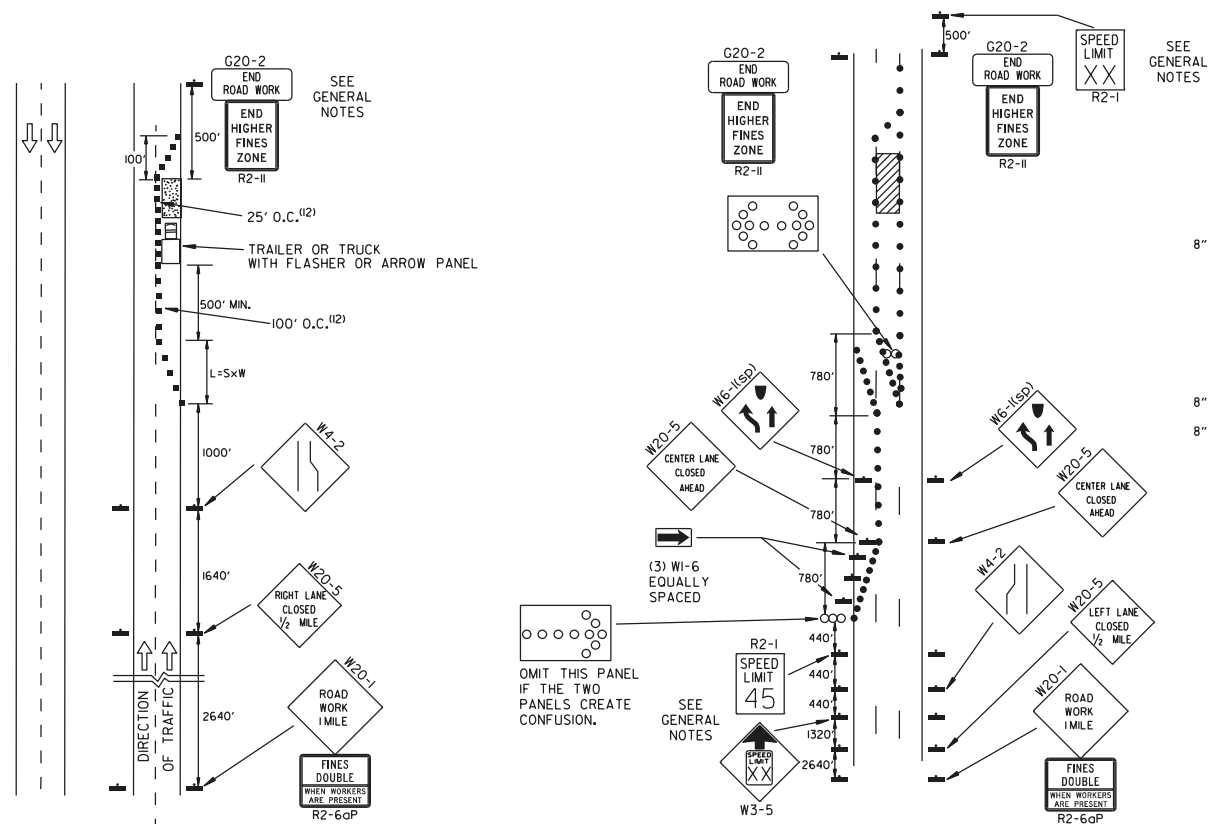

(A) TYPICAL APPLICATION - DAYTIME MAINTENANCE OPERATIONS OF SHORT DURATION ON A 4-LANE DIVIDED ROADWAY WHERE HALF OF THE ROADWAY IS CLOSED.

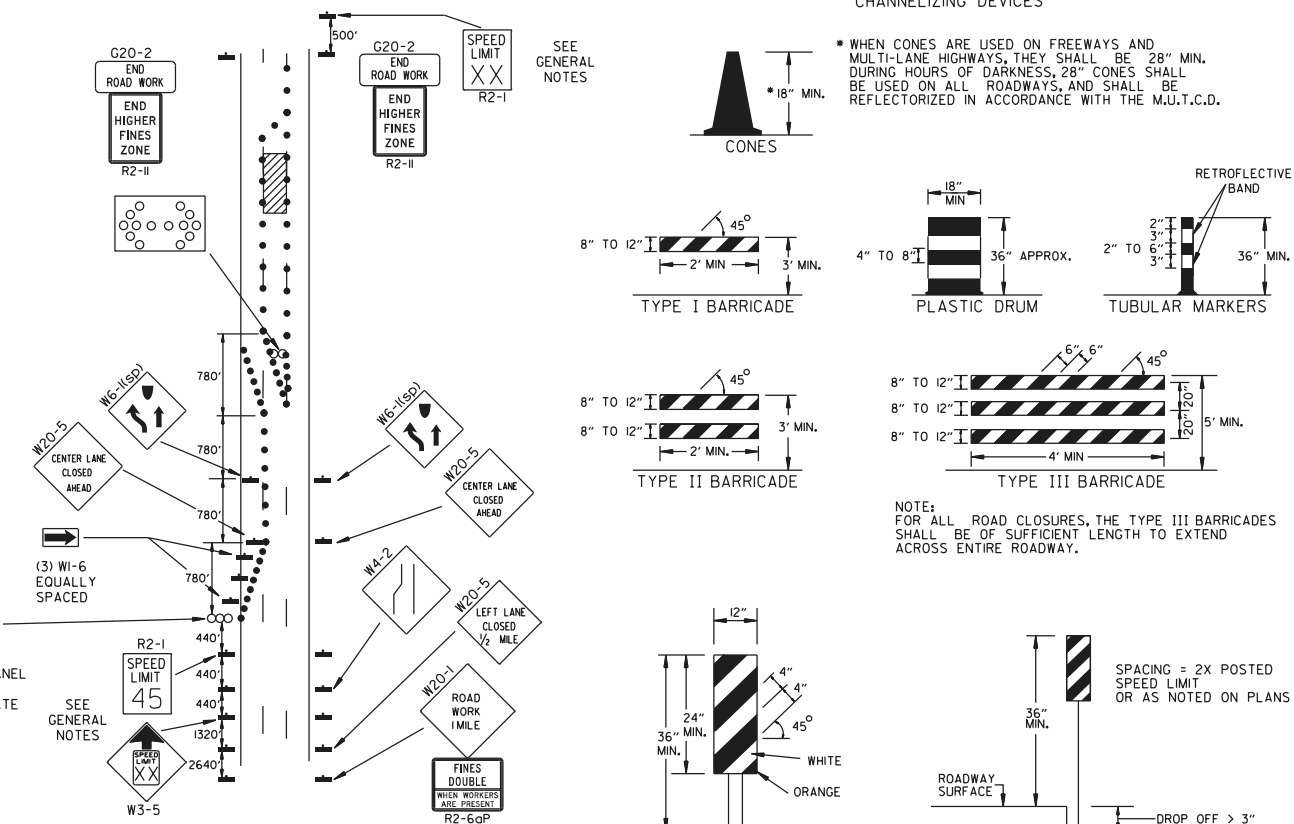

(B) TYPICAL APPLICATION - 3-LANE ONEWAY ROADWAY WHERE CENTER LANE IS CLOSED.

- KEY:
- ○ ○ ○ ○ ARROW PANEL (IF REQUIRED)
 - CHANNELIZING DEVICE
 - TRAFFIC DRUM
- GENERAL NOTES:
- A SPEED LIMIT REDUCTION MAY BE IMPLEMENTED ONLY WHEN DESIGNATED IN THE PLAN OR WHEN RECOMMENDED BY THE ROADWAY DESIGN DIVISION.
 - WHEN THE EXISTING SPEED LIMIT IS 55MPH AND THE PLANS REQUIRE A SPEED LIMIT OF 45MPH, THE R2-1(55) SHALL BE OMITTED AND THE W3-5 SHALL BE INSTALLED AT THAT LOCATION. ADDITIONAL R2-1(45)MPH SPEED LIMIT SIGNS SHALL BE INSTALLED AT A MAXIMUM OF 1/2 MILE INTERVALS. AT THE END OF THE WORK AREA A R2-1(XX) SHALL BE INSTALLED TO MATCH ORIGINAL SPEED LIMIT.
 - WHEN THE EXISTING SPEED LIMIT IS 65MPH AND THE PLANS REQUIRE A SPEED LIMIT OF 55MPH, THE R2-1(65) SHALL BE OMITTED. ADDITIONAL R2-1(55)MPH SPEED LIMIT SIGNS SHALL BE INSTALLED AT A MAXIMUM OF 1/2 MILE INTERVALS. AT THE END OF THE WORK AREA A R2-1(XX) SHALL BE INSTALLED TO MATCH ORIGINAL SPEED LIMIT.
 - THE MAXIMUM SPACING BETWEEN CHANNELIZING DEVICES IN A TAPER SHOULD BE APPROXIMATELY EQUAL IN FEET TO THE SPEED LIMIT. BEYOND THE TAPER, MAXIMUM SPACING SHALL BE TWO TIMES THE SPEED LIMIT OR AS DIRECTED BY THE ENGINEER.
 - WARNING LIGHTS AND/OR FLAGS MAY BE MOUNTED TO SIGNS OR CHANNELIZING DEVICES AT NIGHT AS NEEDED.
 - PAVEMENT MARKINGS NO LONGER APPLICABLE WHICH MIGHT CREATE CONFUSION IN THE MINDS OF VEHICLE OPERATORS SHALL BE REMOVED OR OBLITERATED AS SOON AS PRACTICABLE.
 - THE G20-1 SIGN SHOULD BE INSTALLED ON JOBS OF OVER TWO MILES IN LENGTH. WHEN THE LANE CLOSURE IS NOT AT THE BEGINNING OF THE PROJECT, THE G20-1 SIGN SHALL BE ERECTED 125' IN ADVANCE OF THE JOB LIMIT. ADDITIONAL W20-1(1/2 MILE) SIGNS ARE NOT REQUIRED IN ADVANCE OF LANE CLOSURES THAT BEGIN INSIDE THE PROJECT LIMITS. THE DISTANCE DISPLAYED ON THE G20-1 SIGN SHALL BE STATED TO THE NEAREST WHOLE MILE.
 - FLAGGERS SHALL USE STOP/SLOW PADDLES FOR CONTROLLING TRAFFIC THROUGH WORK ZONES. FLAGS MAY BE USED ONLY FOR EMERGENCY SITUATIONS.
 - ALL PLASTIC DRUMS AND CONES SHALL MEET THE REQUIREMENTS OF MANUAL FOR ASSESSING SAFETY HARDWARE (MASH).
 - TRAILER MOUNTED DEVICES SUCH AS ARROW PANELS AND PORTABLE CHANGEABLE MESSAGE SIGNS SHALL BE DELINEATED BY AFFIXING CONSPICUOUS MATERIAL IN A CONTINUOUS LINE ON THE FACE OF THE TRAILER. WHEN PLACED ON OR ADJACENT TO THE SHOULDER AND NOT BEHIND A POSITIVE BARRIER, THESE DEVICES SHALL BE DELINEATED BY PLACING FIVE (5) TRAFFIC DRUMS, EQUALLY SPACED ALONG THE TRAFFIC SIDE OF THE DEVICE. PAYMENT FOR TRAFFIC DRUMS SHALL BE CONSIDERED INCLUDED IN THE PRICE BID FOR VARIOUS TRAILER MOUNTED DEVICES.
 - ALL TRAILER MOUNTED DEVICES SUCH AS ARROW PANELS AND PORTABLE CHANGEABLE MESSAGE SIGNS SHALL MEET THE REQUIREMENTS OF THE MANUAL FOR ASSESSING SAFETY HARDWARE (MASH).
 - ONLY WHERE SPACE RESTRICTIONS DO NOT ALLOW FOR TRAFFIC DRUMS, TUBULAR MARKERS MAY BE USED AT 50' O.C. IN STABILIZATION ZONES AND AT 10' O.C. DIRECTLY ADJACENT TO CONSTRUCTION OPERATIONS AND AT EXIT TAPERS. TUBULAR MARKERS SHALL BE STABILIZED WITH WEIGHTED BASES IN ACCORDANCE WITH THE M.U.T.C.D.

(C) TYPICAL APPLICATION - CONSTRUCTION OPERATIONS OF INTERMEDIATE TO LONG TERM DURATION ON A 4-LANE DIVIDED ROADWAY WHERE HALF OF THE ROADWAY IS CLOSED.

CHANNELIZING DEVICES

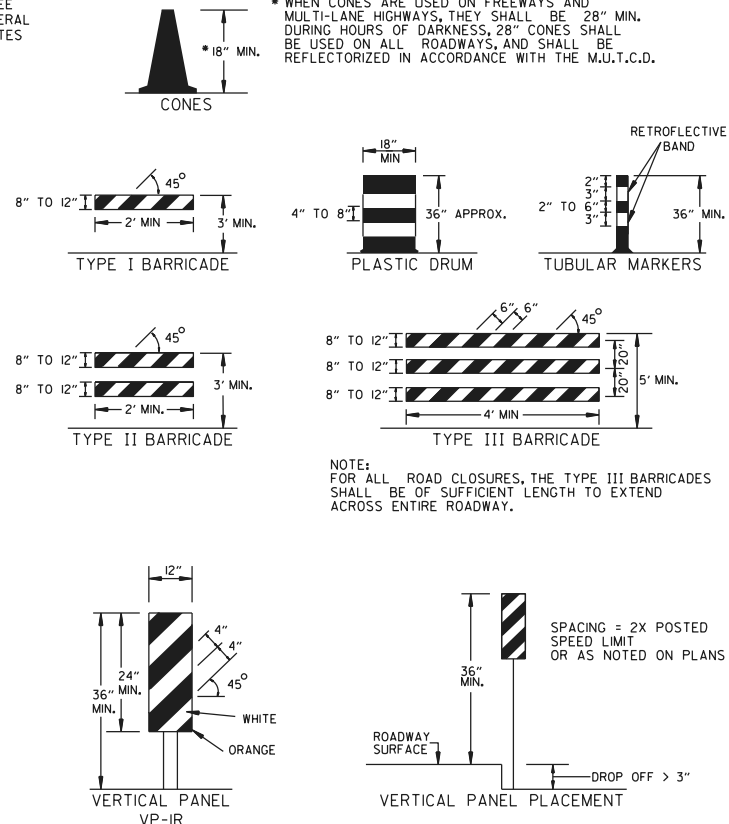

* WHEN CONES ARE USED ON FREEWAYS AND MULTI-LANE HIGHWAYS, THEY SHALL BE 28" MIN. DURING HOURS OF DARKNESS, 28" CONES SHALL BE USED ON ALL ROADWAYS, AND SHALL BE REFLECTORIZED IN ACCORDANCE WITH THE M.U.T.C.D.

NOTE: FOR ALL ROAD CLOSURES, THE TYPE III BARRICADES SHALL BE OF SUFFICIENT LENGTH TO EXTEND ACROSS ENTIRE ROADWAY.

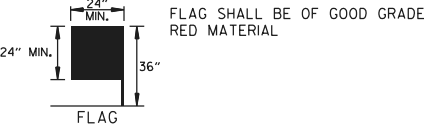

A REVIEW BY THE ROADWAY DESIGN DIVISION OF THE HIGHWAY DEPARTMENT WILL BE REQUIRED PRIOR TO IMPLEMENTING A MULTIPLE LANE CLOSURE.

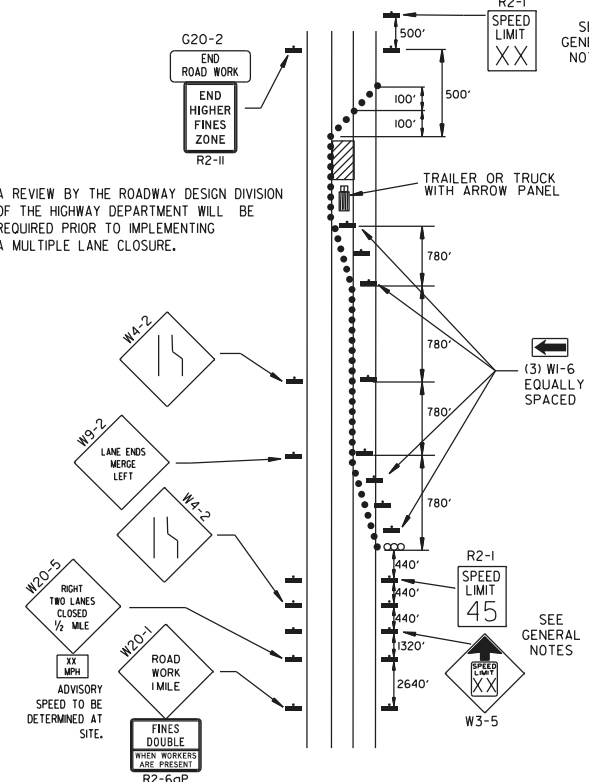

(D) TYPICAL APPLICATION - CLOSING MULTIPLE LANES OF A MULTILANE HIGHWAY.

TRAFFIC CONTROL DEVICES

VERTICAL DIFFERENTIAL	LOCATION	TRAFFIC CONTROL	
		≤ 45 MPH	> 45 MPH
≤ 1"	CENTERLINE	W8-11	W8-11
> 1"	CENTERLINE	W8-11 AND CENTERLINE LANE STRIPING	W8-11 AND CENTERLINE LANE STRIPING
> 3"	CENTERLINE	STANDARD LANE CLOSURE ⁽¹⁾	STANDARD LANE CLOSURE ⁽¹⁾
≤ 3"	EDGE OF TRAVELED LANE OR EDGE OF SHOULDER	W8-9 AND TRAFFIC DRUMS ⁽¹⁾	W8-9 AND TRAFFIC DRUMS ⁽¹⁾
> 3"	EDGE OF TRAVELED LANE OR EDGE OF SHOULDER	W8-17, EDGE LINE STRIPING, AND TRAFFIC DRUMS ⁽¹⁾	W8-17, EDGE LINE STRIPING, AND TRAFFIC DRUMS ⁽¹⁾
> 6"	EDGE OF TRAVELED LANE OR EDGE OF SHOULDER	W8-17, EDGE LINE STRIPING, AND TRAFFIC DRUMS ⁽¹⁾	W8-17, EDGE LINE STRIPING, AND TRAFFIC DRUMS ⁽²⁾
> 18"	EDGE OF TRAVELED LANE OR EDGE OF SHOULDER	W8-17, EDGE LINE STRIPING, AND TRAFFIC DRUMS ⁽¹⁾	A STABILIZED WEDGE, W8-17, EDGE LINE STRIPING, AND TRAFFIC DRUMS ⁽²⁾
> 24"	EDGE OF TRAVELED LANE OR EDGE OF SHOULDER	PRECAST CONCRETE BARRIER ⁽⁴⁾ & EDGE LINES	PRECAST CONCRETE BARRIER ⁽⁴⁾ & EDGE LINES

INTERSTATE		
VERTICAL DIFFERENTIAL	LOCATION	TRAFFIC CONTROL
≤ 3"	CENTERLINE	W8-11 AND LANE STRIPING
≤ 3"	EDGE OF TRAVELED LANE OR EDGE OF SHOULDER	W8-9, EDGE LINE STRIPING, AND TRAFFIC DRUMS ⁽²⁾
> 3"	EDGE OF TRAVELED LANE OR EDGE OF SHOULDER	W8-17, EDGE LINE STRIPING, AND TRAFFIC DRUMS ⁽²⁾
> 6"	EDGE OF TRAVELED LANE OR EDGE OF SHOULDER	PRECAST CONCRETE BARRIER & EDGE LINES

INTERSTATE AND NON-INTERSTATE		
FORESLOPE	HEIGHT	TRAFFIC CONTROL
1:1	> 2 FT	PRECAST CONCRETE BARRIER
2:1	≤ 5 FT	TRAFFIC DRUMS
2:1	> 5 FT	PRECAST CONCRETE BARRIER
Flatter than 2:1	N/A	TRAFFIC DRUMS

- GENERAL NOTES:
- WHEN THE SHOULDER AREA IS USED AS PART OF THE TRAVELED LANE AND THERE IS INSUFFICIENT WIDTH TO PLACE TRAFFIC DRUMS ON THE REMAINING SHOULDER WIDTH, THEN VERTICAL PANELS SHALL BE USED.
 - WHEN THERE IS INSUFFICIENT WIDTH TO PLACE TRAFFIC DRUMS ON THE REMAINING SHOULDER WIDTH, A STABILIZED WEDGE SHALL BE USED. PRECAST CONCRETE BARRIER WALL CAN BE USED IN LIEU OF A STABILIZED WEDGE, W8-17 SIGN, EDGE LINE STRIPING, AND TRAFFIC DRUMS. IF AND WHERE DIRECTED BY THE ENGINEER, A STABILIZED WEDGE, W8-17 SIGN, EDGE LINE STRIPING, AND TRAFFIC DRUMS CAN BE USED IN LIEU OF PRECAST CONCRETE BARRIER WALL. IF AND WHERE DIRECTED BY THE ENGINEER, W21-5, W21-5a, AND/OR W21-5b SIGNS SHALL BE USED WHERE THE ROADWAY IS UNOBSTRUCTED IF AND WHERE DIRECTED BY THE ENGINEER. TIME LIMITATIONS MUST CONFORM TO SECTION 603 OF THE STANDARD SPECIFICATIONS FOR HIGHWAY CONSTRUCTION (CURRENT EDITION).

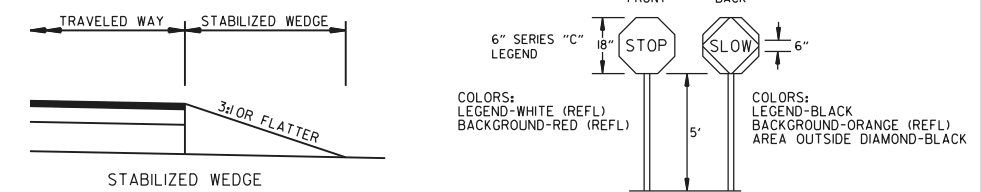

NOTE: MATERIALS FOR THE STABILIZED WEDGE SHALL MEET THE REQUIREMENTS PROVIDED IN SECTION 603.02 OF THE STANDARD SPECIFICATIONS.

NOTES:
 USE SPLICES ONLY WHEN NECESSARY FOR INSTALLATION. TYPICAL INSTALLATION SHOULD HAVE NO SPLICES (SEE STD. DRAWING NO. SHS-2)
 NORMAL INSTALLATIONS WILL REQUIRE 1/4" DIA. BOLTS TO MOUNT SIGNS TO POST AND 5/16" DIA. BOLTS TO ASSEMBLE THE VARIOUS POST SUPPORTS. EACH OF THESE BOLTS SHALL BE CARRIAGE BOLTS.
 SIGN POSTS SHALL BE PAINTED GREEN; SIGNS SHALL NOT BE PAINTED, AND ALL SIGN POSTS SHALL BE PLUMB.

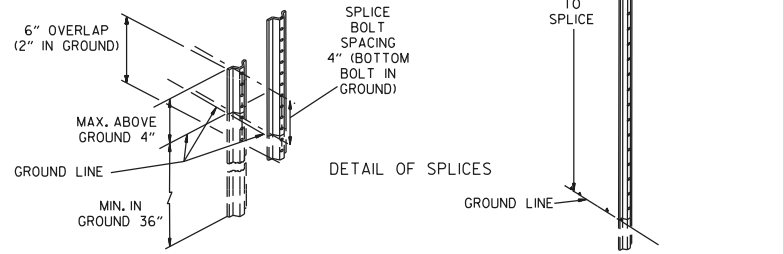

08-14-25	ADDED R2-6aP AND R2-11	<p>ARKANSAS STATE HIGHWAY COMMISSION</p> <p>STANDARD TRAFFIC CONTROLS FOR HIGHWAY CONSTRUCTION</p>	DATE EFFECTIVE	STANDARD DRAWING	TC-3
05-22-25	REVISED TRAFFIC CONTROL DEVICES AND NOTES, ADDED NOTE 12		08-14-2025		
08-12-21	REVISED TRAFFIC CONTROL DEVICES AND NOTES				
05-20-21	REVISED NOTE 10				
02-27-20	REVISED TRAFFIC CONTROL DEVICES DETAILS				

NOTE : W20-1 (VARIOUS DISTANCE) ADVANCE SIGNS TO BE REPLACED AS NEEDED BY EQUIVALENT W20-5 SIGNS AS WORKING AREA SHIFTS.

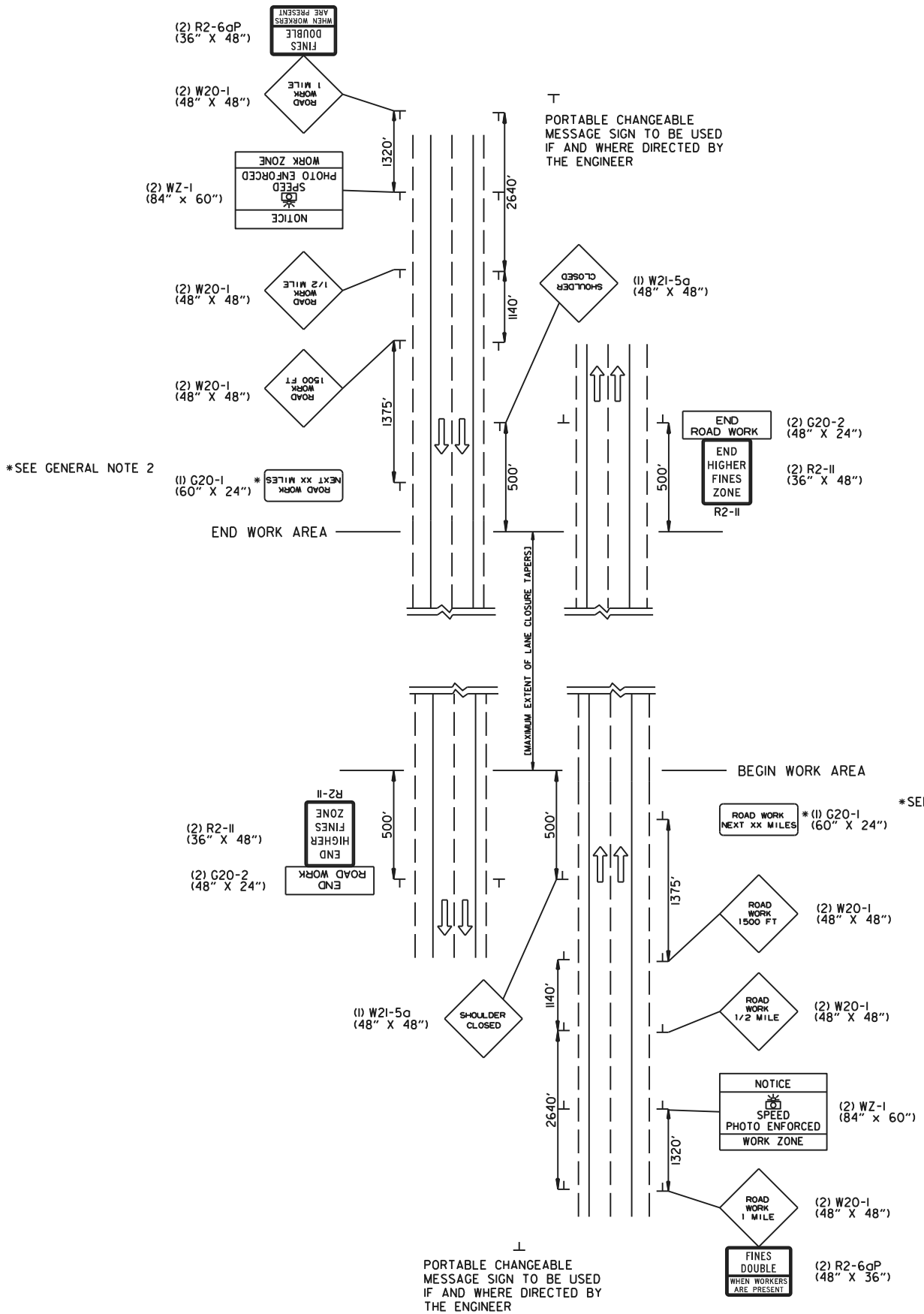

(A) TYPICAL APPLICATION - ADVANCE WARNING SIGNS AT BEGINNING AND END OF JOB (FULLY CONTROLLED ACCESS FACILITIES) (ALL STAGES)

*SEE GENERAL NOTE 2

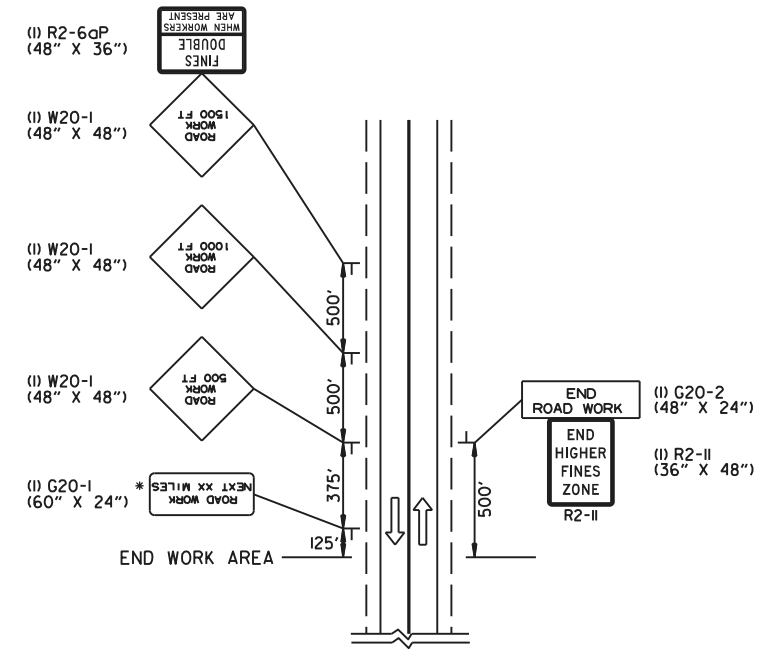

(B) TYPICAL APPLICATION - ADVANCE WARNING SIGNS AT BEGINNING AND END OF JOB (NON-FULLY CONTROLLED ACCESS FACILITIES) (ALL STAGES)

GENERAL NOTES:

1. WARNING LIGHTS AND/OR FLAGS MAY BE MOUNTED TO SIGNS OR CHANNELIZING DEVICES AT NIGHT AS NEEDED.
2. THE G20-1 SIGN SHOULD BE INSTALLED ON JOBS OF OVER TWO MILES IN LENGTH, WHEN THE LANE CLOSURE IS NOT AT THE BEGINNING OF THE PROJECT, THE G20-1 SIGN SHALL BE ERECTED 125' IN ADVANCE OF THE JOB LIMIT. ADDITIONAL W20-1 (1 MILE OR 1500 FT) SIGNS ARE NOT REQUIRED IN ADVANCE OF LANE CLOSURES THAT BEGIN INSIDE THE PROJECT LIMITS. THE DISTANCE DISPLAYED ON THE G20-1 SIGN SHALL BE STATED TO THE NEAREST WHOLE MILE.
3. PORTABLE CHANGEABLE MESSAGE SIGNS SHALL BE DELINEATED BY AFFIXING CONSPICUITY MATERIAL IN A CONTINUOUS LINE ON THE FACE OF THE TRAILER, WHEN PLACED ON OR ADJACENT TO THE SHOULDER AND NOT BEHIND A POSITIVE BARRIER, THIS DEVICE SHALL BE DELINEATED BY PLACING FIVE (5) TRAFFIC DRUMS, EQUALLY SPACED ALONG THE TRAFFIC SIDE OF THE DEVICE. PAYMENT FOR TRAFFIC DRUMS SHALL BE CONSIDERED INCLUDED IN THE PRICE BID FOR PORTABLE CHANGEABLE MESSAGE SIGNS.
4. PORTABLE CHANGEABLE MESSAGE SIGNS SHALL MEET THE REQUIREMENTS OF THE MANUAL FOR ASSESSING SAFETY HARDWARE (MASH).

*SEE GENERAL NOTE 2

NOTE : W20-1 (VARIOUS DISTANCE) ADVANCE SIGNS TO BE REPLACED AS NEEDED BY EQUIVALENT W20-5 SIGNS AS WORKING AREA SHIFTS.

08-14-25 DATE REV	ISSUED	DESCRIPTION			ARKANSAS STATE HIGHWAY COMMISSION	
			STANDARD TRAFFIC CONTROLS FOR HIGHWAY CONSTRUCTION			
DATE EFFECTIVE		STANDARD DRAWING		TC-6		
08-14-2025						