

DATE REVISED	DATE REVISION	FED. RD. DIST. NO.	STATE	JOB NO.	SHEET NO.	TOTAL SHEETS
06-07-22		6	ARK.	012392	1	25
HYDRODEMOLITION BRIDGE PRESERVATION (2022) (S)						

ARKANSAS DEPARTMENT OF TRANSPORTATION
CONSTRUCTION PLANS

HYDRODEMOLITION BRIDGE
PRESERVATION (2022) (S)

VARIOUS COUNTIES
JOB 012392

FED. AID PROJ. NHPP-BFP-0076(271)

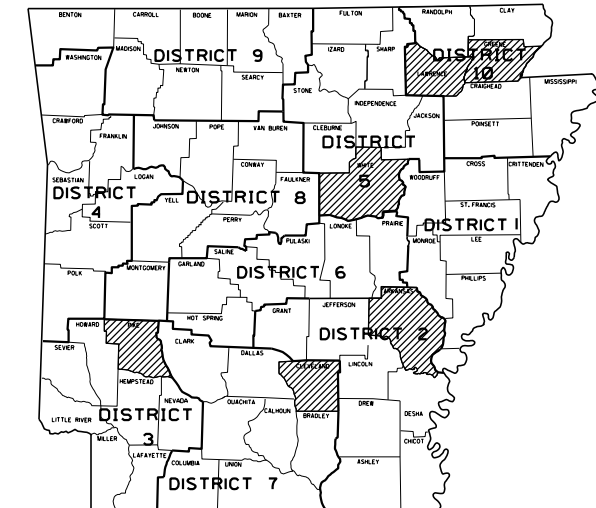

ARKANSAS HIGHWAY DISTRICTS 2, 3, 5, 7 & 10

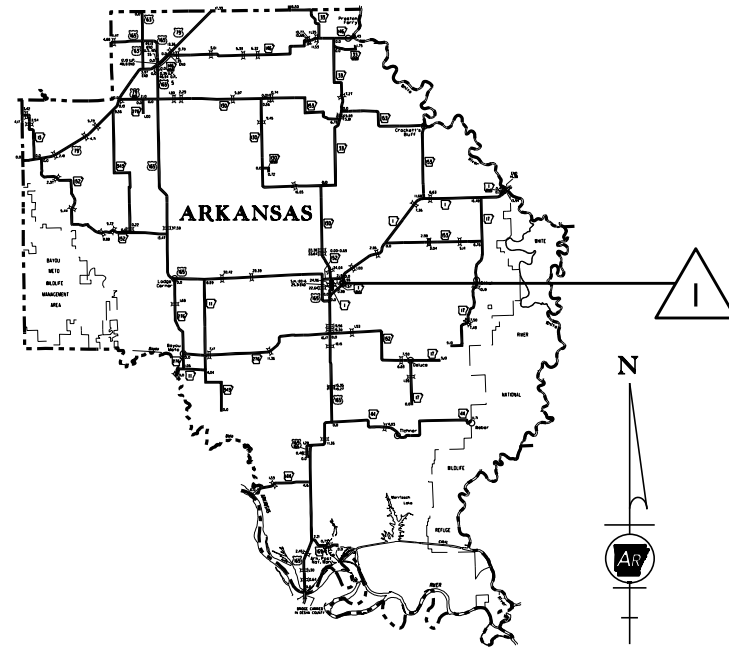

DISTRICT 2
NOT TO SCALE

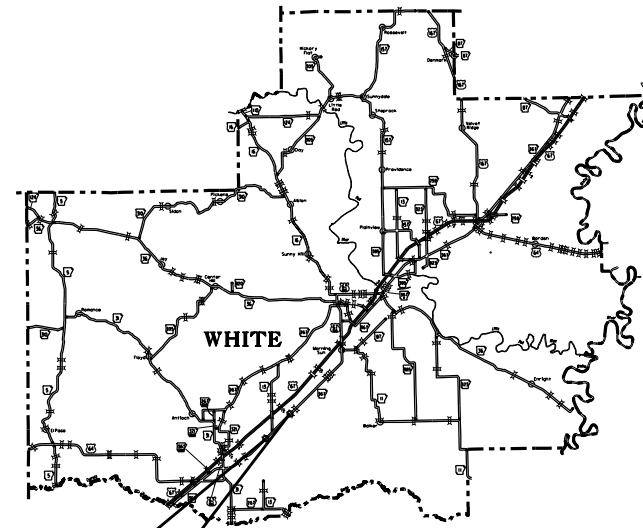

DISTRICT 5
NOT TO SCALE

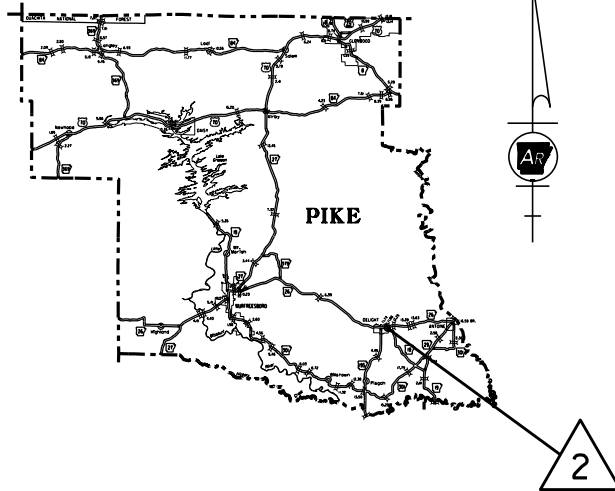

DISTRICT 3
NOT TO SCALE

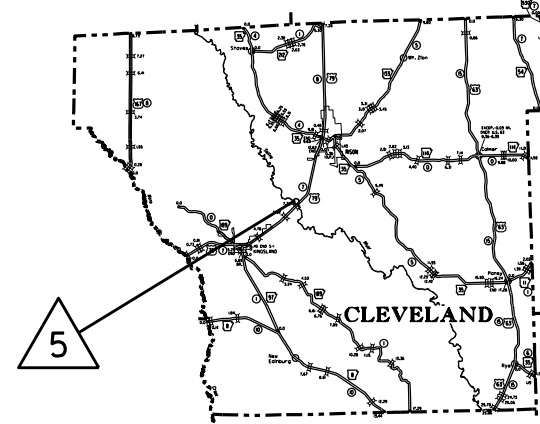

DISTRICT 7
NOT TO SCALE

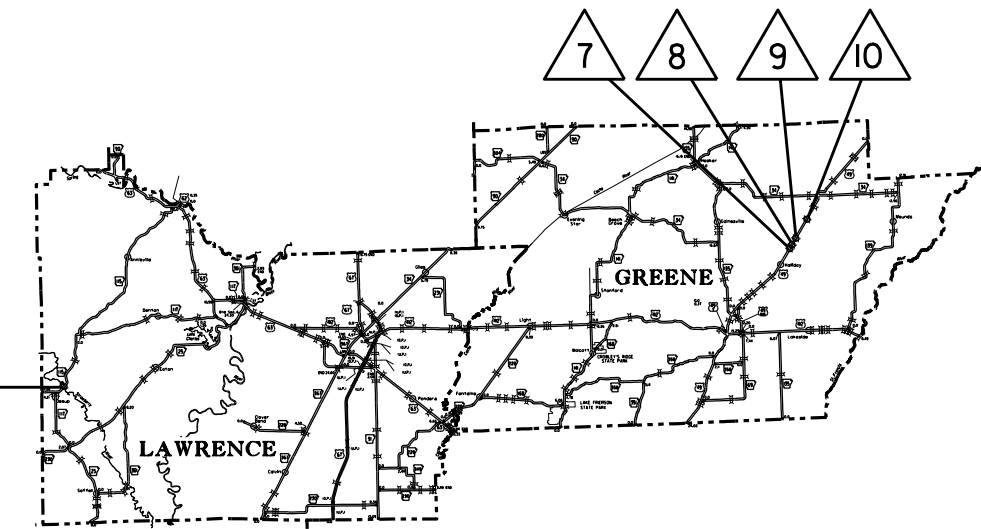

DISTRICT 10
NOT TO SCALE

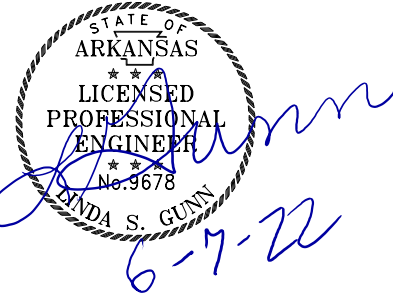

LENGTH CALCULATED ALONG C. L. BRIDGES			
NET LENGTH OF ROADWAY	0000.00	FEET	0.000 MILES
NET LENGTH OF BRIDGES	3486.50	FEET	0.660 MILES
NET LENGTH OF PROJECT	3486.50	FEET	0.660 MILES

- NOTES:
- BRIDGE DATA IS ON PLAN SHEET 2.
 - REFER TO SPECIAL DETAILS FOR INSET ENLARGEMENTS AT BRIDGE LOCATIONS.

T:\civil\kay\proj\06-07-22\012392-Hydrodemolition Bridge Preservation\Design\Civil - Bridge Only\Drawings\012392_01_CO_001.dgn
 WORKSPACE: ARDOT\B7919_012392-Hydrodemolition Bridge Preservation\Design\Civil - Bridge Only\Drawings\012392_01_CO_001.dgn
 REVISION DATE: **REVISION**

DATE REVISED	DATE REVISED	FED. RD. DIST. NO.	STATE	JOB NO.	SHEET NO.	TOTAL SHEETS
		6	ARK.	012392	2	25
BRIDGE DATA						

LEGEND



HYDRODEMOLITION
& LATEX MODIFIED CONCRETE OVERLAY

BRIDGE DATA



4-26-22



HWY. 1, SEC. 4
LOG MILE 1.551 BR. END
OVER PRICES BRANCH
90'-0" BRIDGE NO. 03384
28'-0" CLEAR ROADWAY
(HYDRO & LMC OVERLAY)



HWY. 79, SEC. 7
LOG MILE 7.771 BR. END
OVER SALINE RIVER
2013'-2" BRIDGE NO. 03011
26'-0" CLEAR ROADWAY
(HYDRO & LMC OVERLAY)



HWY. 49, SEC. 2
LOG MILE 7.177 BR. END
OVER LOCUST CREEK
75'-0" BRIDGE NO. 03085
28'-0" CLEAR ROADWAY
(HYDRO & LMC OVERLAY)



HWY. 26, SEC. 3
LOG MILE 11.726 BR. END
OVER WOLF CREEK
152'-3" BRIDGE NO. 02735
24'-0" CLEAR ROADWAY
(HYDRO & LMC OVERLAY)



HWY. 115, SEC. 2
LOG MILE 16.045 BR. END
OVER STRAWBERRY RIVER
700'-1" BRIDGE NO. 03253
24'-0" CLEAR ROADWAY
(HYDRO & LMC OVERLAY)



HWY. 49, SEC. 2
LOG MILE 6.177 BR. END
OVER SLAVENS CREEK
75'-0" BRIDGE NO. 03086
28'-0" CLEAR ROADWAY
(HYDRO & LMC OVERLAY)



HWY. 367, SEC. 15
LOG MILE 8.028 BR. END
OVER LAWRENCE BAYOU
50'-0" BRIDGE NO. 01446
27'-0" CLEAR ROADWAY
(HYDRO & LMC OVERLAY)



HWY. 49, SEC. 2
LOG MILE 9.207 BR. END
OVER HENDERSON CREEK
75'-0" BRIDGE NO. 03083
28'-0" CLEAR ROADWAY
(HYDRO & LMC OVERLAY)



HWY. 367, SEC. 15
LOG MILE 5.455 BR. END
OVER GUM BAYOU
181'-0" BRIDGE NO. 01462
24'-0" CLEAR ROADWAY
(HYDRO & LMC OVERLAY)



HWY. 49, SEC. 2
LOG MILE 8.699 BR. END
OVER HURRICANE CREEK
75'-0" BRIDGE NO. 03084
28'-0" CLEAR ROADWAY
(HYDRO & LMC OVERLAY)

C:\Users\jweld\OneDrive\Documents\4/26/2022 12:55:42 PM
 WORKSPACE: ARDOT
 Y:\Projects\ARDOT\18799\012392-Hydrodemolition Bridge Preservation\Design\Civil - Bridge Only\Drawings\012392_04_BRIDGE_DATA.dgn
 REVISED DATE: **REVIDATE**

DATE REVISED	DATE REVISED	FED. RD. DIST. NO.	STATE	JOB NO.	SHEET NO.	TOTAL SHEETS
		6	ARK.	012392	3	25
INDEX OF SHEETS AND STANDARD DRAWINGS						

INDEX OF SHEETS

SHEET NO.	TITLE	BRIDGE NO.	DRWG.NO.
1	TITLE SHEET		
2	BRIDGE DATA		
3	INDEX OF SHEETS AND STANDARD DRAWINGS		
4	GOVERNING SPECIFICATIONS AND GENERAL NOTES		
5 - 8	TYPICAL SECTIONS OF IMPROVEMENT		
9 - 14	SPECIAL DETAILS		
15 - 16	MAINTENANCE OF TRAFFIC DETAILS		
17	PERMANENT PAVEMENT MARKING DETAILS		
18 - 20	QUANTITIES		
21	SCHEDULE OF BRIDGE QUANTITIES – DISTRICTS 2, 3, 5, 7, & 10	ALL BRIDGES	65175
22	SUMMARY OF QUANTITIES AND REVISIONS		
23	BRIDGE PRESERVATION DATA TABLE – DISTRICTS 2, 3, 5, 7, & 10	ALL BRIDGES	65176
24	RAILING REPAIR DETAILS	BR. 03086	65177
25	CONCRETE REPAIR DETAILS	ALL BRIDGES	65178

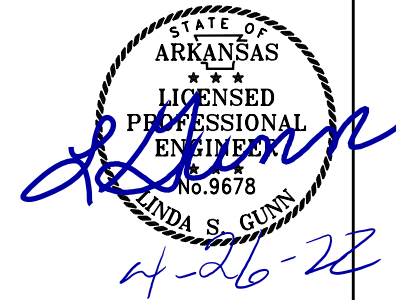

BRIDGE STANDARD DRAWINGS

DRWG.NO.	TITLE	DATE
55060	STANDARD DETAILS FOR HYDRODEMOLITION AND LMC OVERLAY SLAB ON BEAM/GIRDER BRIDGES	06-25-20
55061	STANDARD DETAILS FOR HYDRODEMOLITION AND LMC OVERLAY SLAB ON BEAM/GIRDER BRIDGES WITH GRADE RAISE	06-25-20
55062	STANDARD DETAILS FOR HYDRODEMOLITION AND LMC OVERLAY REINFORCED CONCRETE SLAB STRUCTURES	06-25-20
55063	STANDARD DETAILS FOR HYDRODEMOLITION AND LMC OVERLAY VOIDED CONCRETE SLAB STRUCTURES	06-25-20
55064	STANDARD DETAILS FOR JOINT REPAIRS & MODIFICATION	11-07-19
55065	STANDARD DETAILS FOR BACKWALL REPAIRS	11-07-19

ROADWAY STANDARD DRAWINGS

DRWG.NO.	TITLE	DATE
PM-1	PAVEMENT MARKING DETAILS	02-27-20
TC-1	STANDARD TRAFFIC CONTROLS FOR HIGHWAY CONSTRUCTION	11-07-19
TC-2	STANDARD TRAFFIC CONTROLS FOR HIGHWAY CONSTRUCTION	05-20-21
TC-3	STANDARD TRAFFIC CONTROLS FOR HIGHWAY CONSTRUCTION	08-12-21
TC-4	STANDARD TRAFFIC CONTROLS FOR HIGHWAY CONSTRUCTION-TEMPORARY PRECAST BARRIER	11-07-19
TC-5	STANDARD TRAFFIC CONTROLS FOR HIGHWAY CONSTRUCTION-TEMPORARY PRECAST BARRIER	11-07-19

C:\Users\jweld\OneDrive\Documents\4/26/2022 12:55:42 PM
 WORKSPACE: ARDOT
 Y:\Projects\ARDOT\187919_012392-Hydrodemolition Bridge Preservation\Design\Civil - Bridge Only\Drawings\012392_02_IND_001.dgn
 REVISED DATE: **REVE DATE**

DATE REVISED	DATE REVISED	FED. RD. DIST. NO.	STATE	JOB NO.	SHEET NO.	TOTAL SHEETS
06-07-22		6	ARK.	012392	4	25
GOVERNING SPECIFICATIONS & GENERAL NOTES						



GENERAL NOTES

- BRIDGE ANALYSIS SHALL BE REQUIRED PER SECTION 105.14 OF THE STANDARD SPECIFICATIONS. A BRIDGE ANALYSIS SHALL BE REQUIRED PRIOR TO HYDRODEMOLITION AND ANOTHER ANALYSIS SHALL BE REQUIRED DURING THE HYDRODEMOLITION PROCESS.
- THE CONTRACTOR SHALL BE RESPONSIBLE FOR MAINTAINING U.S. MAILBOXES WITHIN THE PROJECT LIMITS IN SUCH A MANNER THAT THE PUBLIC MAY RECEIVE CONTINUED MAIL SERVICE. PAYMENT WILL BE CONSIDERED INCLUDED IN THE PRICE BID FOR THE VARIOUS BID ITEMS.
- ALL LAND MONUMENTS LOCATED WITHIN THE CONSTRUCTION AREA SHALL BE PROTECTED IN ACCORDANCE WITH SECTION 107.12 OF THE STANDARD SPECIFICATIONS.
- THE CONTRACTOR, AT HIS OWN EXPENSE, SHALL BE RESPONSIBLE FOR PROVIDING A FENCE TO CONTROL AND CONTAINED LIVESTOCK IF FENCING OF PASTURES IS SEVERED.
- ALL TREES THAT DO NOT DIRECTLY INTERFERE WITH THE PROPOSED CONSTRUCTION SHALL BE SPARED IF AND WHERE DIRECTED BY THE ENGINEER. CARE AND DISCRETION SHALL BE USED TO ENSURE THAT ALL TREES NOT TO BE REMOVED SHALL BE HARMED AS LITTLE AS POSSIBLE DURING THE CONSTRUCTION OPERATIONS.
- PREPARATORY WORK, SUCH AS CLIPPING THE GRASS AND DEBRIS FROM THE EDGE OF THE EXISTING ROADWAY, WILL NOT BE PAID FOR DIRECTLY, BUT WILL BE CONSIDERED A PART OF THE OTHER ITEMS OF WORK. AFTER THE ROADWAY IS COMPLETED, THIS MATERIAL SHALL BE PULLED UP TO THE EDGE OF THE NEW PAVEMENT AT LOCATIONS WHERE THE DROP OFF IS GREATER THAN 4" RESULTING FROM THE TRANSITIONS OR GUARDRAIL ROADWAY IMPROVEMENTS. NO DIRECT PAYMENT WILL BE MADE FOR THIS WORK.
- ASPHALT DEBRIS RESULTING FROM THE PREPARATORY WORK SHALL BE REMOVED FROM THE PROJECT. THIS MATERIAL SHALL NOT BE BURIED OR STOCKPILED WITHIN THE RIGHT OF WAY.
- THE ENGINEER MAY REQUIRE THE CONTRACTOR TO MODIFY THEIR SCHEDULE, DURING WORK WHEN SPECIAL EVENTS OR OCCURRENCES MAY CAUSE TRAFFIC TO BECOME CONGESTED.
- THE EXISTING ASPHALT PAVEMENT TO BE REMOVED FROM THE REMAINING PAVEMENT SHALL BE SEPARATED BY SAWING ALONG A NEAT LINE. AFTER SAWING, THE PAVEMENT TO BE REMOVED SHALL BE CAREFULLY REMOVED IN A MANNER THAT WILL NOT DAMAGE THE PAVEMENT THAT IS TO REMAIN. ANY DAMAGE OF THE ASPHALT PAVEMENT THAT IS TO REMAIN IN PLACE SHALL BE REPAIRED AT THE CONTRACTOR'S EXPENSE.
- ROADWAY COLD MILLED TRANSITION SHALL BE OVERLAID WITHIN 7 CALENDAR DAYS. IF AN AREA OF THE PROJECT HAS BEEN COLD MILLED AND IS NOT OVERLAID ON OR BEFORE THE 7TH DAY, NO ADDITIONAL COLD MILLING SHALL TAKE PLACE UNTIL THE MILLED AREA IS OVERLAID.
- ANY EQUIPMENT OR APPURTENANCE THAT INTERFERES WITH THE PROPOSED CONSTRUCTION AND WHICH MAY BE THE PROPERTY OF UTILITY SERVICE ORGANIZATIONS SHALL BE MOVED BY THE OWNERS UNLESS OTHERWISE PROVIDED.
- THE SEQUENCE AS SHOWN ON THE MAINTENANCE OF TRAFFIC PLANS IS A GENERAL OUTLINE FOR THE CONSTRUCTION OF THIS PROJECT, AND IN NO WAY IS IT INTENDED TO COVER EVERY ITEM IN THE PROJECT. ITEMS NOT CRITICAL TO THE CONSTRUCTION SEQUENCE MAY BE CONSTRUCTED IN ANY STAGE IF AND WHERE DIRECTED BY THE ENGINEER.
- BRIDGE PRESERVATION PROJECTS AND PAVEMENT PRESERVATION PROJECTS ARE ONGOING SIMULTANEOUSLY IN ALL DISTRICTS IN ARKANSAS. THE CONTRACTOR SHALL COORDINATE THE BRIDGE PRESERVATION SCHEDULE WITH THE DISTRICT AND PRIORITIZE BRIDGE REHABILITATION IF AND WHERE DIRECTED BY THE ENGINEER IN ORDER FOR THE BRIDGE PRESERVATION TO BE COMPLETED BEFORE THE ASSOCIATED PAVEMENT PRESERVATION PROJECT BEGINS WORK. THERE SHALL BE NO DIRECT PAYMENT FOR FULFILLING THIS REQUIREMENT, BUT PAYMENT WILL BE CONSIDERED INCLUDED IN THE PRICE BID FOR THE VARIOUS CONTRACT ITEMS.

GOVERNING SPECIFICATIONS

ARKANSAS STATE HIGHWAY COMMISSION STANDARD SPECIFICATIONS FOR HIGHWAY CONSTRUCTION, EDITION OF 2014, AND THE FOLLOWING SPECIAL PROVISIONS AND SUPPLEMENTAL SPECIFICATIONS:

NUMBER	TITLE
ERRATA	ERRATA FOR THE BOOK OF STANDARD SPECIFICATIONS
FHWA-1273	REQUIRED CONTRACT PROVISIONS FEDERAL-AID CONSTRUCTION CONTRACTS
FHWA-1273	SUPPLEMENT - EQUAL EMPLOYMENT OPPORTUNITY - NOTICE TO CONTRACTORS
FHWA-1273	SUPPLEMENT - SPECIFIC EQUAL EMPLOYMENT OPPORTUNITY RESPONSIBILITIES (23 U.S.C. 140)
FHWA-1273	SUPPLEMENT - EQUAL EMPLOYMENT OPPORTUNITY - GOALS AND TIMETABLES
FHWA-1273	SUPPLEMENT - EQUAL EMPLOYMENT OPPORTUNITY - FEDERAL STANDARDS
FHWA-1273	SUPPLEMENT - POSTERS AND NOTICES REQUIRED FOR FEDERAL-AID PROJECTS
FHWA-1273	SUPPLEMENT - WAGE RATE DETERMINATION
100-3	CONTRACTOR'S LICENSE
100-4	DEPARTMENT NAME CHANGE
102-2	ISSUANCE OF PROPOSALS
105-4	MAINTENANCE DURING CONSTRUCTION
107-2	RESTRAINING CONDITIONS
108-1	LIQUIDATED DAMAGES
108-2	WORK ALLOWED PRIOR TO ISSUANCE OF WORK ORDER
306-1	QUALITY CONTROL AND ACCEPTANCE
400-1	TACK COATS
400-4	DESIGN AND QUALITY CONTROL OF ASPHALT MIXTURES
400-5	PERCENT AIR VOIDS FOR ACHM MIX DESIGNS
400-6	LIQUID ANTI-STRIP ADDITIVE
400-7	TRACKLESS TACK
404-3	DESIGN OF ASPHALT MIXTURES
410-1	CONSTRUCTION REQUIREMENTS AND ACCEPTANCE OF ASPHALT CONCRETE PLANT MIX COURSES
410-2	DEVICES FOR MEASURING DENSITY FOR ROLLING PATTERNS
410-4	EVALUATION OF ACHM SUBLOT REPLACEMENT MATERIAL
501-2	CEMENT
603-1	LANE CLOSURE NOTIFICATION
604-1	RETROREFLECTIVE SHEETING FOR TRAFFIC CONTROL DEVICES IN CONSTRUCTION ZONES
604-3	TRAFFIC CONTROL DEVICES IN CONSTRUCTION ZONES (MASH)
800-1	STRUCTURES
802-4	CEMENT
804-2	REINFORCING STEEL FOR STRUCTURES
JOB 012392	ASSESSMENT OF WORKING DAYS - MAINTENANCE OF TRAFFIC
JOB 012392	BIDDING REQUIREMENTS AND CONDITIONS
JOB 012392	BRIDGE DECK REPAIR FOR LATEX MODIFIED CONCRETE OVERLAYS
JOB 012392	BROADBAND INTERNET SERVICE FOR ASPHALT CONCRETE PLANT
JOB 012392	CARGO PREFERENCE ACT REQUIREMENTS
JOB 012392	COLD MILLING - COUNTY PROPERTY
JOB 012392	CONCRETE BRIDGE DECK CURING AND SURFACE TREATMENT RESTRICTIONS
JOB 012392	CONCRETE REPAIRS
JOB 012392	COORDINATION OF WORK
JOB 012392	DOCUMENTATION OF PAYMENTS MADE TO DISADVANTAGED BUSINESS ENTERPRISES
JOB 012392	HYDRODEMOLITION - CLASS 2
JOB 012392	JOINT REHABILITATION FOR BRIDGE DECKS
JOB 012392	LATEX MODIFIED CONCRETE OVERLAY
JOB 012392	LIQUIDATED DAMAGES PROCEDURE FOR BID LETTINGS
JOB 012392	LONGITUDINAL JOINT DENSITIES FOR ACHM SURFACE COURSES
JOB 012392	MAINTENANCE OF TRAFFIC
JOB 012392	MANDATORY ELECTRONIC CONTRACT
JOB 012392	MANDATORY ELECTRONIC DOCUMENT SUBMITTAL
JOB 012392	NESTING SITES OF MIGRATORY BIRDS
JOB 012392	PARTNERING REQUIREMENTS
JOB 012392	PORTABLE TRAFFIC SIGNAL SYSTEM
JOB 012392	PRICE ADJUSTMENT FOR ASPHALT BINDER
JOB 012392	PROHIBITION OF CERTAIN TELECOMMUNICATIONS AND VIDEO SURVEILLANCE SERVICE OR EQUIPMENT
JOB 012392	RAILING REPAIR
JOB 012392	SUBMISSION OF ASPHALT CONCRETE HOT MIX ACCEPTANCE TEST RESULTS
JOB 012392	TRAFFIC CONTROL DEVICES IN CONSTRUCTION ZONES
JOB 012392	VALUE ENGINEERING
JOB 012392	WARM MIX ASPHALT
JOB 012392	WATER POLLUTION CONTROL

T:\civil\kay\refec_6/6/2022_855h5 AM
 WORKSPACE\AR001
 Y:\Projects\AR001\8799_012392-Hydrodemolition Bridge Preservation\Design\Civil - Bridge Only\Drawings\AR012392_03_CN_001.dgn
 REVISED DATE: **REVE DATE**

DATE REVISED	DATE REVISED	FED. RD. DIST. NO.	STATE	JOB NO.	SHEET NO.	TOTAL SHEETS
		6	ARK.	012392	10	25
SPECIAL DETAILS						

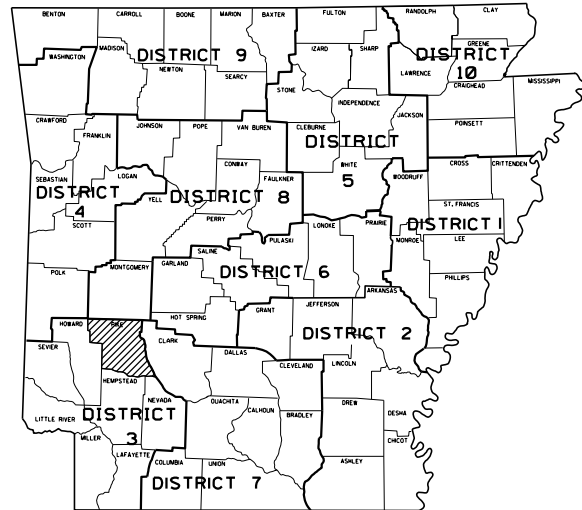

ARKANSAS HIGHWAY DISTRICT 3

LEGEND

△ - HYDRODEMOLITION & LATEX MODIFIED CONCRETE OVERLAY

2 HWY. 26, SEC. 3
 LOG MILE 11.726 BR. END
 OVER WOLF CREEK
 152'-3" BRIDGE NO. 02735
 24'-0" CLEAR ROADWAY
 (HYDRO & LMC OVERLAY)

R27W | R26W | R25W | R24W | R23W

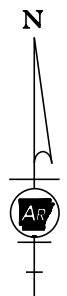
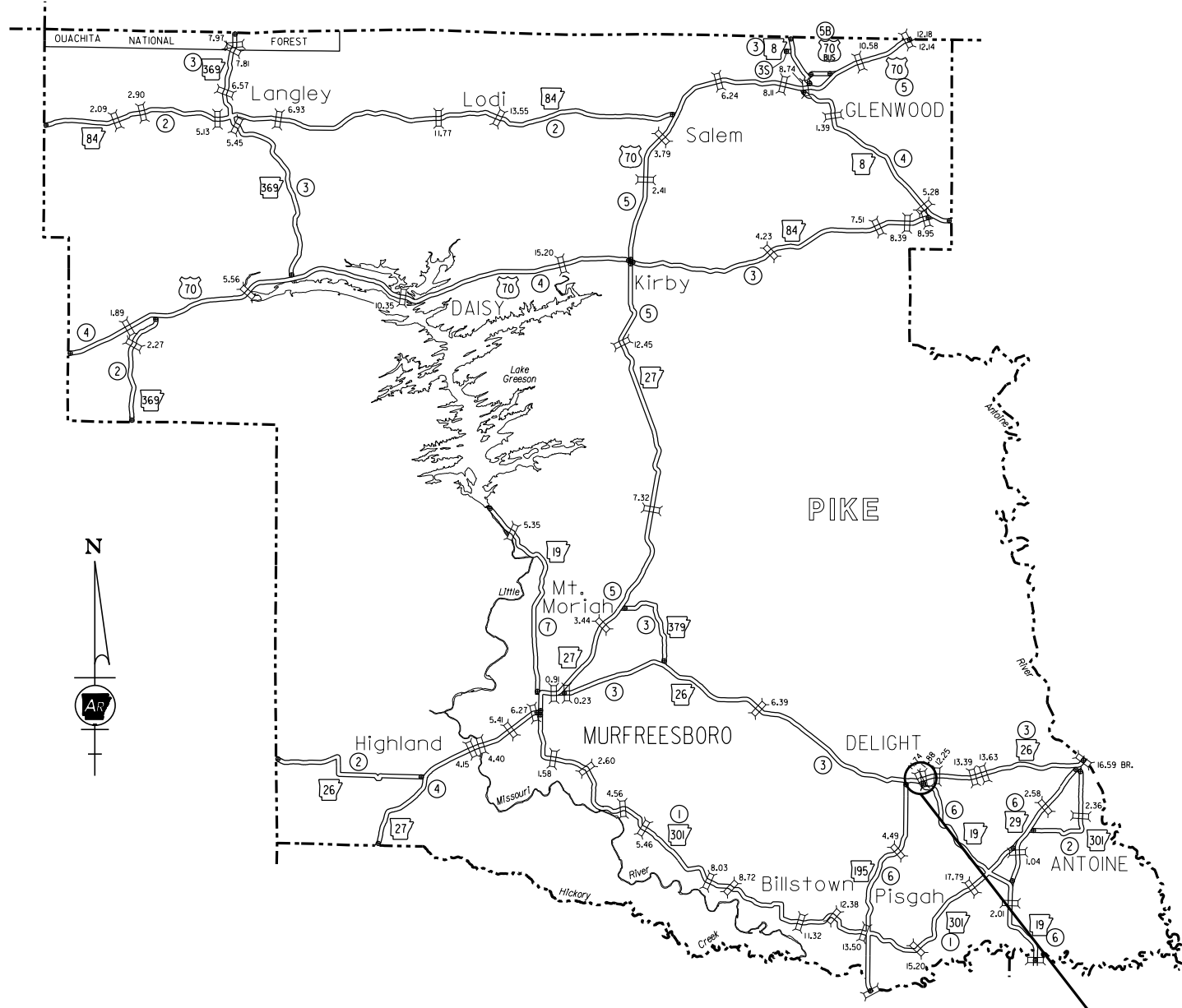

**DISTRICT 3
 INSET - 2
 NOT TO SCALE**

STATE OF ARKANSAS
 LICENSED PROFESSIONAL ENGINEER
 No. 9678
 LINDA S. GUNN
L. S. Gunn
 4-26-22

— T O S —
 — T O S —
 — T O S —
 — T O S —

C:\Users\l\OneDrive\Documents\4/26/2022 12:55:50 PM
 WORKSPACE: ARDOT\B7919_012392_Hydrodemolition Bridge Preservation\Design\Civil - Bridge Only\Drawings\012392_05_SD_001.dgn
 Y:\Projects\ARDOT\B7919_012392_Hydrodemolition Bridge Preservation\Design\Civil - Bridge Only\Drawings\012392_05_SD_001.dgn
 REVISION DATE: **REVISION DATE**

DATE REVISED	DATE REVISED	FED. RD. DIST. NO.	STATE	JOB NO.	SHEET NO.	TOTAL SHEETS
		6	ARK.	012392	II	25
SPECIAL DETAILS						

STATE OF
ARKANSAS

LICENSED
PROFESSIONAL
ENGINEER

No. 9678
LINDA S. GUNN

4-26-22

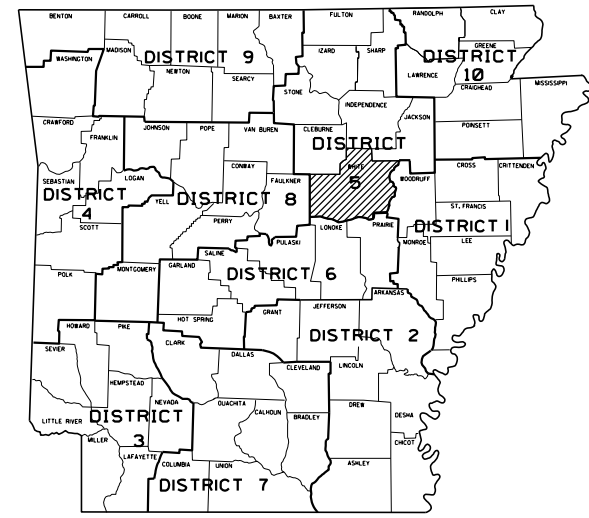

ARKANSAS HIGHWAY DISTRICT 5

RIOW | R9W | R8W | R7W | R6W | R5W | R4W

LEGEND

△ - HYDRODEMOLITION & LATEX MODIFIED CONCRETE OVERLAY

- ③ HWY. 367, SEC. 15
LOG MILE 8.028 BR. END
OVER LAWRENCE BAYOU
50'-0" BRIDGE NO. 01446
27'-0" CLEAR ROADWAY
(HYDRO & LMC OVERLAY)
- ④ HWY. 367, SEC. 15
LOG MILE 5.455 BR. END
OVER GUM BAYOU
181'-0" BRIDGE NO. 01462
24'-0" CLEAR ROADWAY
(HYDRO & LMC OVERLAY)

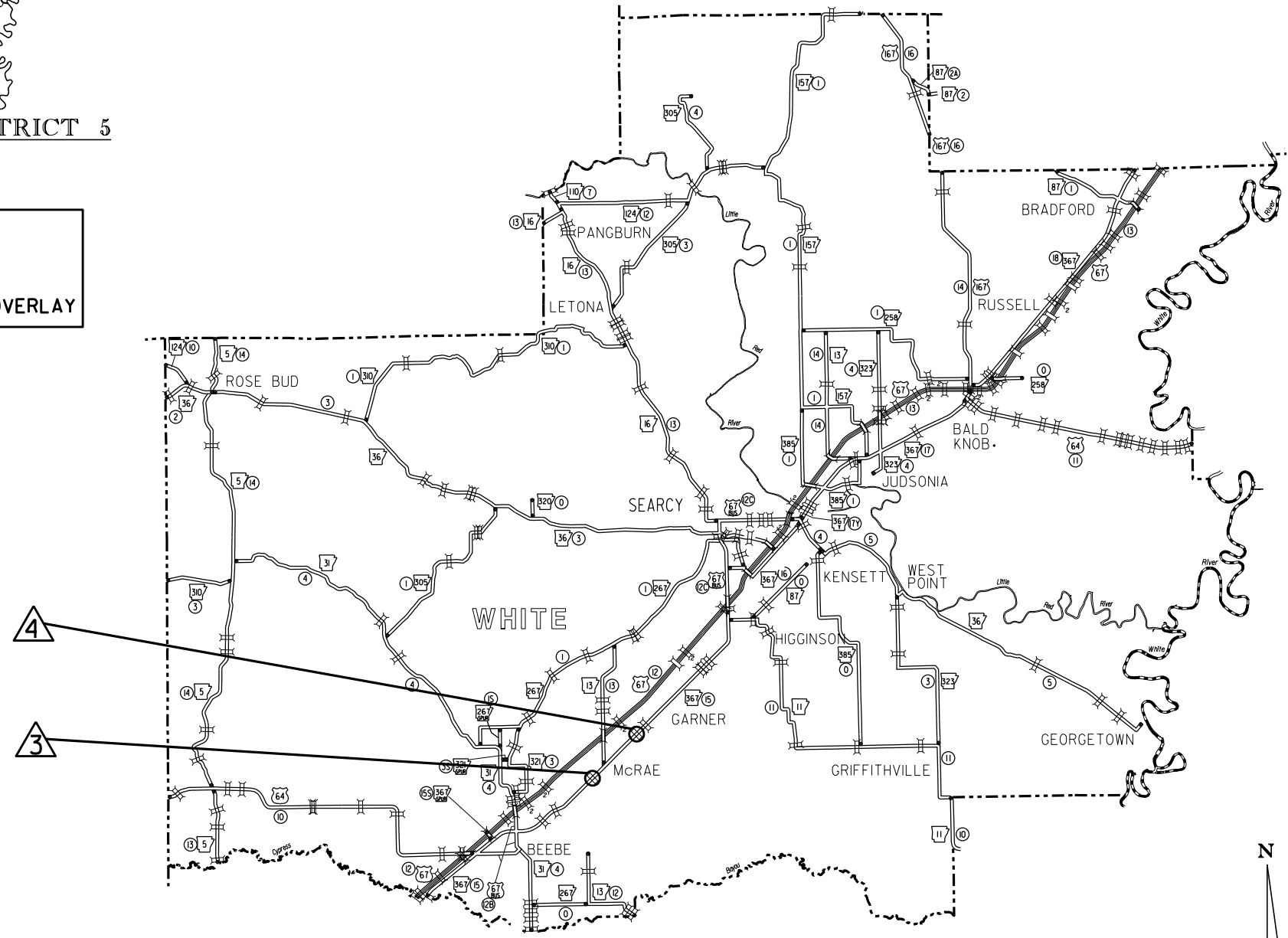

**DISTRICT 5
INSET - 3
NOT TO SCALE**

C:\Users\lshid\OneDrive\Documents\4/26/2022 12:55:51 PM
 WORKSPACE: ARDOT\B7919_012392-Hydrodemolition Bridge Preservation\Design\Civil - Bridge Only\Drawings\012392_05_SD_001.dgn
 Y:\Projects\ARDOT\B7919_012392-Hydrodemolition Bridge Preservation\Design\Civil - Bridge Only\Drawings\012392_05_SD_001.dgn
 REVISION DATE: **REVISION DATE**

DATE REVISED	DATE REVISED	FED. RD. DIST. NO.	STATE	JOB NO.	SHEET NO.	TOTAL SHEETS
		6	ARK.	012392	15	25
MAINTENANCE OF TRAFFIC DETAILS						

 4-26-22

- MAINTENANCE OF TRAFFIC NOTES:**
- THE CONTRACTOR SHALL PROVIDE 2-WAY RADIO COMMUNICATION FOR FLAG PERSON FOR CONSTRUCTION UNDER TRAFFIC.
 - THE CONTRACTOR SHALL FURNISH AND MAINTAIN STD. W8-1 "BUMP" SIGNS (30" X 30") WITH BLACK LEGEND ON ORANGE BACKGROUND AT ALL TRANSVERSE JOINTS EXPOSED TO TRAFFIC.
 - THE CONTRACTOR SHALL FURNISH AND MAINTAIN STD. W8-II "UNEVEN LANES" SIGNS (48" X 48") WITH BLACK LEGEND ON ORANGE BACKGROUND AT ALL LONGITUDINAL JOINTS DURING MILLING AND PAVING OPERATIONS.
 - THE EDGE LINES SHALL NOT BE PLACED ON THE FINISHED ASPHALT SURFACE UNTIL AFTER ALL WORK ADJACENT TO THE PAVEMENT EDGE, INCLUDING SPREADING, COMPACTING AND ETC. IS COMPLETED IN ORDER TO AVOID DAMAGING THE EDGE LINES.

- MAINTENANCE OF TRAFFIC NOTES (CONT.):**
- FLAGGING MAY BE USED IF AND WHERE DIRECTED BY THE ENGINEER.

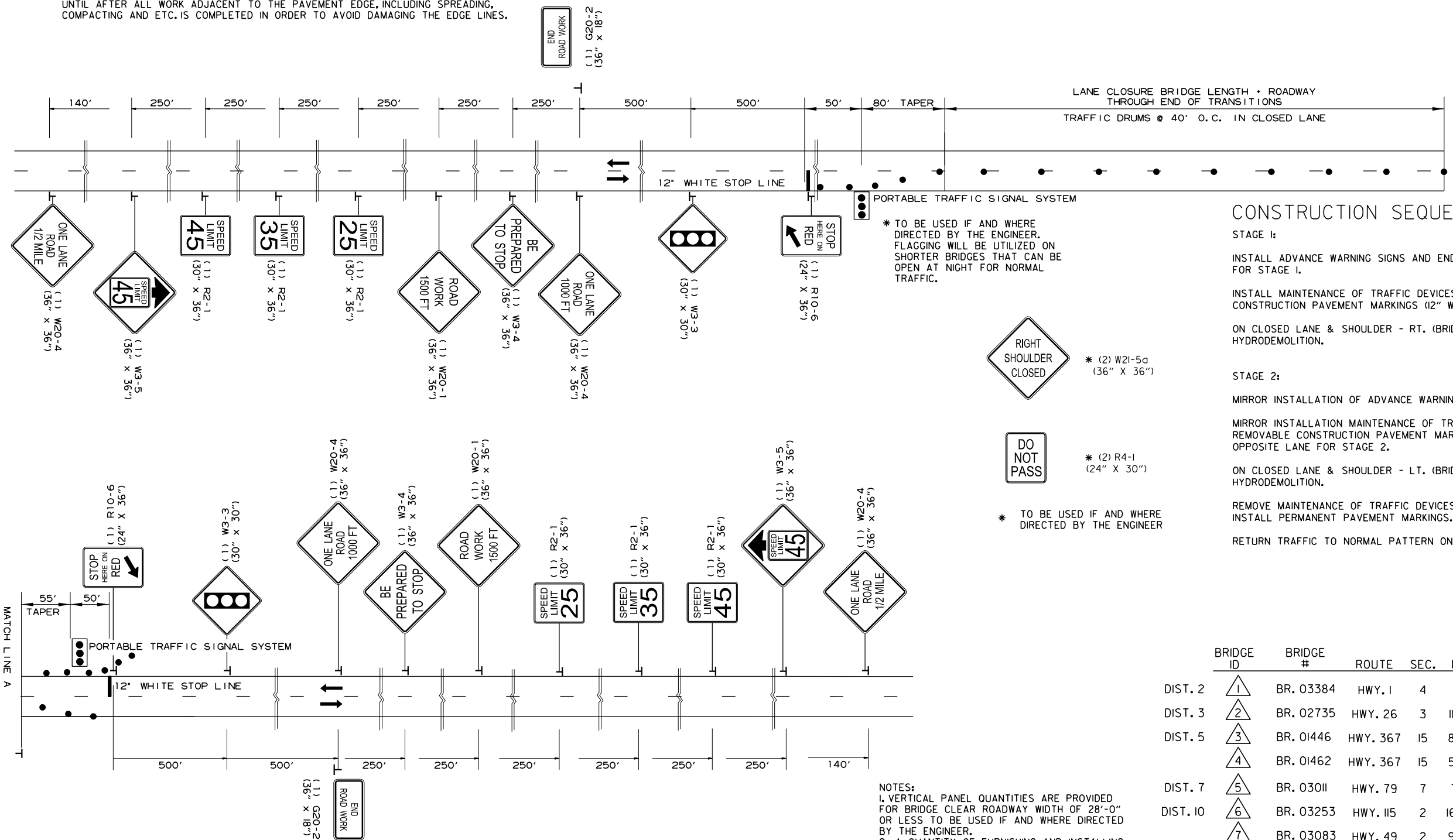

CONSTRUCTION SEQUENCE

STAGE 1:

INSTALL ADVANCE WARNING SIGNS AND END ROAD WORK SIGNS AT THE LOCATIONS SHOWN FOR STAGE 1.

INSTALL MAINTENANCE OF TRAFFIC DEVICES AS SHOWN IN STAGE 1 AND REMOVABLE CONSTRUCTION PAVEMENT MARKINGS (12" WH. STOP LINES).

ON CLOSED LANE & SHOULDER - RT. (BRIDGE AND ROADWAY): CONSTRUCT BRIDGE HYDRODEMOLITION.

STAGE 2:

MIRROR INSTALLATION OF ADVANCE WARNING SIGNS AND END ROAD WORK SIGNS FOR STAGE 2.

MIRROR INSTALLATION MAINTENANCE OF TRAFFIC DEVICES FOR STAGE 2 AND INSTALL REMOVABLE CONSTRUCTION PAVEMENT MARKINGS (12" WH. STOP LINES). SHIFT TRAFFIC ONTO OPPOSITE LANE FOR STAGE 2.

ON CLOSED LANE & SHOULDER - LT. (BRIDGE AND ROADWAY): CONSTRUCT BRIDGE HYDRODEMOLITION.

REMOVE MAINTENANCE OF TRAFFIC DEVICES & REMOVABLE CONSTRUCTION PAVEMENT MARKINGS. INSTALL PERMANENT PAVEMENT MARKINGS.

RETURN TRAFFIC TO NORMAL PATTERN ON ROADWAY.

	BRIDGE ID	BRIDGE #	ROUTE	SEC.	LOG MILE	TRAFFIC DRUMS	BR. DECK CLEAR ROADWAY WIDTH
DIST. 2	1	BR. 03384	HWY. 1	4	1.551	17	28' - 0"
DIST. 3	2	BR. 02735	HWY. 26	3	11.726	19	24' - 0"
DIST. 5	3	BR. 01446	HWY. 367	15	8.028	16	27' - 0"
	4	BR. 01462	HWY. 367	15	5.455	20	24' - 0"
DIST. 7	5	BR. 03011	HWY. 79	7	7.771	65	26' - 0"
DIST. 10	6	BR. 03253	HWY. 115	2	16.045	33	24' - 0"
	7	BR. 03083	HWY. 49	2	9.207	17	28' - 0"
	8	BR. 03084	HWY. 49	2	8.699	17	28' - 0"
	9	BR. 03085	HWY. 49	2	7.177	17	28' - 0"
	10	BR. 03086	HWY. 49	2	6.177	17	28' - 0"

- NOTES:**
- VERTICAL PANEL QUANTITIES ARE PROVIDED FOR BRIDGE CLEAR ROADWAY WIDTH OF 28'-0" OR LESS TO BE USED IF AND WHERE DIRECTED BY THE ENGINEER.
 - A QUANTITY OF FURNISHING AND INSTALLING PRECAST CONC. BARRIER AND RELOCATION HAS BEEN PROVIDED FOR THE BACKWALL REPAIR ON BR. 6 - 03253.
 - SPECIAL END UNITS ARE TO BE INCLUDED IN THE BID PRICE FOR FURN. & INSTALLING PRECAST CONCRETE BARRIER.
 - REFER TO STANDARD DRAWINGS TC-4 AND TC-5 FOR BARRIER WALL PLACEMENT.

LANE CLOSURE WITH PORTABLE TRAFFIC SIGNAL SYSTEM & TRAFFIC DRUMS FOR HYDRODEMOLITION BRIDGES (VAR. CLEAR ROADWAY ON THE BRIDGE DECKS)

ADVANCE WARNING (2 LANE ROADWAY) MAINTENANCE OF TRAFFIC DETAILS

4/26/2022 12:55:54 PM
 C:\Users\Wj\OneDrive\Workspaces\AR001\87919_012392-Hydrodemolition Bridge Preservation\Design\Civil - Bridge Only\Drawings\012392_06_MOT_001.dgn
 Y:\Projects\AR001\87919_012392-Hydrodemolition Bridge Preservation\Design\Civil - Bridge Only\Drawings\012392_06_MOT_001.dgn
 REVISED DATE: **REDATE**

LEGEND

- TRAFFIC DRUM
- ⊥ TEMPORARY TRAFFIC SIGN
- ➔ TRAFFIC FLOW ARROWS

DATE REVISED	DATE REVISED	FED. RD. DIST. NO.	STATE	JOB NO.	SHEET NO.	TOTAL SHEETS
		6	ARK.	012392	16	25
MAINTENANCE OF TRAFFIC DETAILS						

STATE OF
ARKANSAS

LICENSED
PROFESSIONAL
ENGINEER
No. 9678
L. S. GUNN
L. S. GUNN

4-26-22

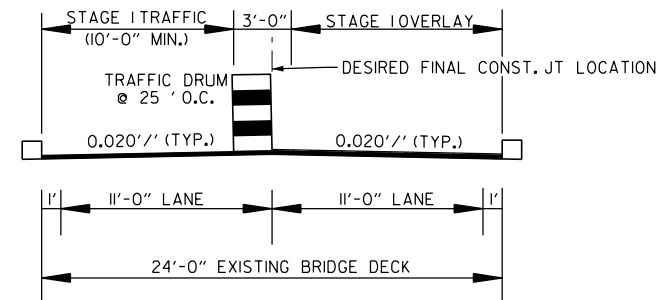

2 LANE BRIDGES

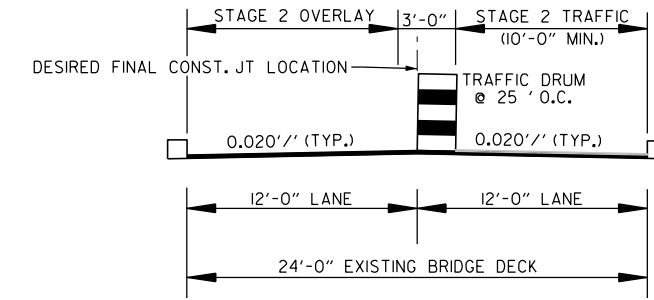

2 LANE BRIDGES

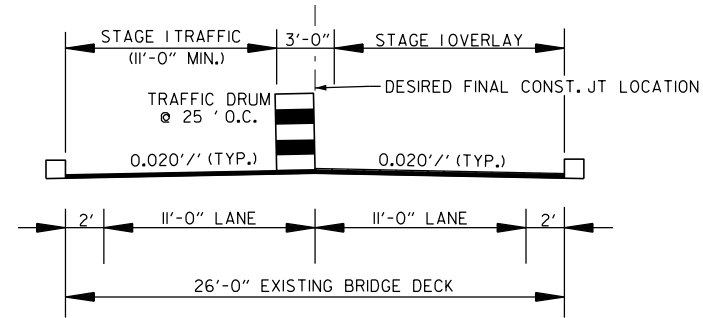

2 LANE BRIDGES

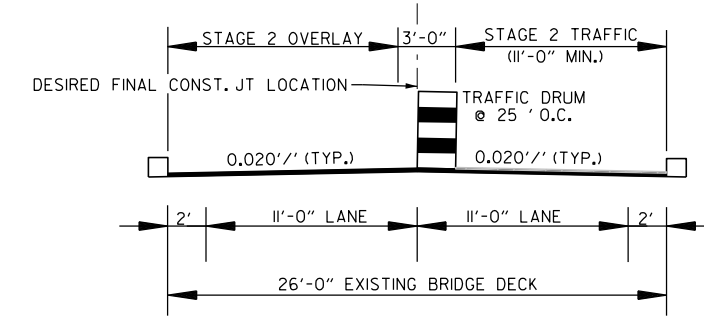

2 LANE BRIDGES

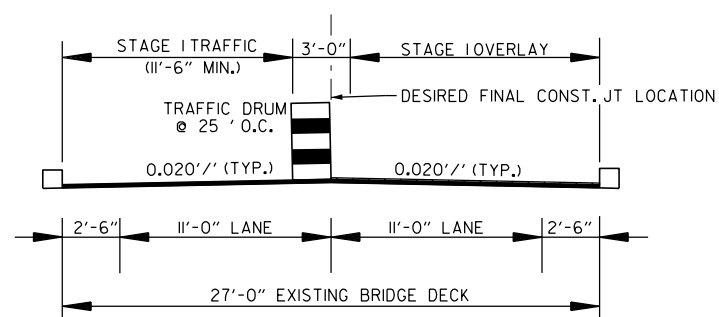

2 LANE BRIDGES

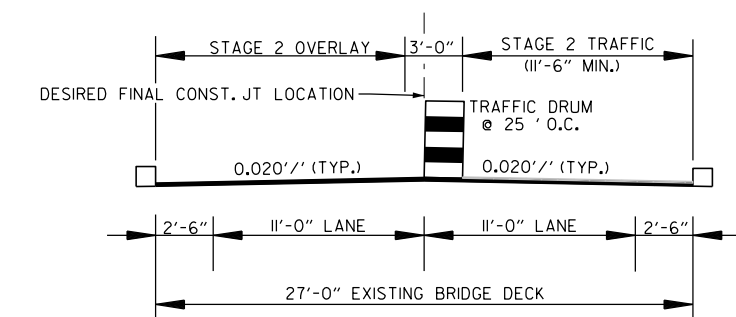

2 LANE BRIDGES

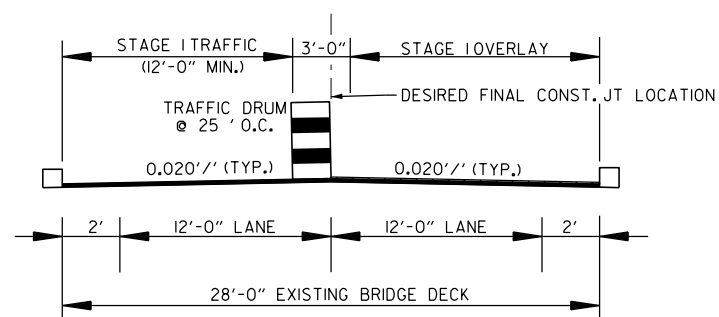

2 LANE BRIDGES

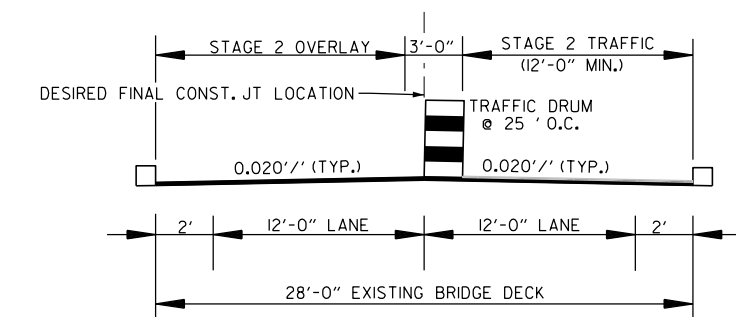

2 LANE BRIDGES

TYPICAL SECTIONS
(2 LANE ROADWAYS)
MAINTENANCE
OF TRAFFIC DETAILS

4/26/2022 12:55:55 PM
 C:\Users\lweid\OneDrive\Workspaces\AR001\Projects\AR001\87919_012392-Hydrodemolition Bridge Preservation\Design\Civil - Bridge Only\Drawings\012392_06_MOT_002.dgn
 WORKSPACE: AR001
 Y:\Projects\AR001\87919_012392-Hydrodemolition Bridge Preservation\Design\Civil - Bridge Only\Drawings\012392_06_MOT_002.dgn
 REVISION DATE: **REVISION**

DATE REVISED	DATE REVISED	FED. RD. DIST. NO.	STATE	JOB NO.	SHEET NO.	TOTAL SHEETS
		6	ARK.	012392	17	25
PERMANENT PAVEMENT MARKING DETAILS						

STATE OF ARKANSAS
 LICENSED PROFESSIONAL ENGINEER
 No. 9678
 LINDA S. GUNN

H-26-22

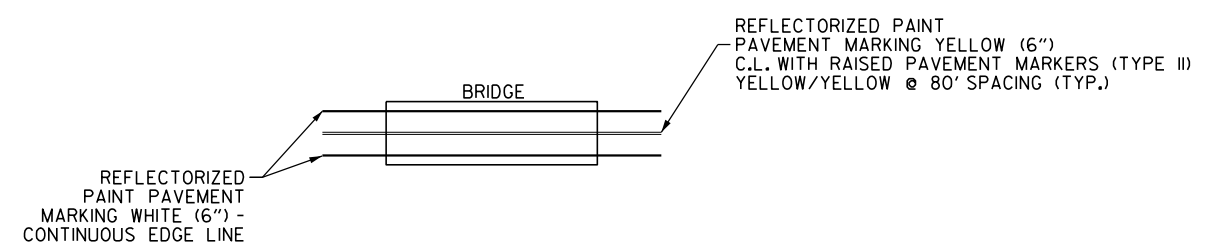

BRIDGES < 2,000 ADT

	BRIDGE ID	BRIDGE #	ROUTE	SECTION	LOG MILE
DIST. 3	2	BR. 02735	HWY. 26	3	11.726
DIST. 5	3	BR. 01446	HWY. 367	15	8.028
DIST. 10	6	BR. 03253	HWY. 115	2	16.045

PERMANENT PAVEMENT MARKING DETAILS
TWO LANE ROADWAYS W/ BRIDGE

- NOTES:
- BRIDGE AND ROADWAY DIMENSIONS VARY FOR EACH SITE. REFER TO TYPICAL SECTIONS.
 - PAVEMENT MARKINGS ARE TO BE PLACED FROM BEGINNING OF TRANSITION LEADING INTO EACH SITE THROUGH ENDING TRANSITION. REFER TO "COLD MILLING ASPHALT PAVEMENT" QUANTITY BOX FOR TRANSITION LENGTHS AT EACH BRIDGE SITE.
 - REFER TO "PERMANENT PAVEMENT MARKINGS" QUANTITY BOX FOR STRIPING AND RAISED PAVEMENT MARKER QUANTITIES AT EACH BRIDGE SITE.

NOTE: THE 6" YELLOW STRIPING QUANTITY HAS BEEN ESTIMATED BASED ON A DOUBLE YELLOW CENTERLINE STRIPE FOR THE ENTIRE PROJECT. THE PROJECT MUST BE MARKED FOR PASSING/NO PASSING ZONES PRIOR TO THE PLACEMET OF THE FINAL STRIPING. CONTACT THE MAINTENANCE DIVISION AFTER THE FINAL LIFT OF SURFACE COURSE HAS BEEN PLACED TO SCHEDULE THE ZONING OF THE PROJECT.

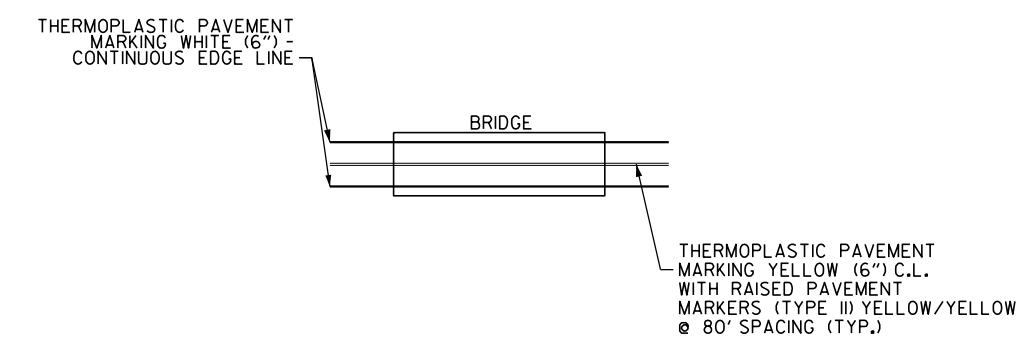

BRIDGES > 2,000 ADT

	BRIDGE ID	BRIDGE #	ROUTE	SECTION	LOG MILE
DIST. 2	1	BR. 03384	HWY. 1	4	1.551
DIST. 5	4	BR. 01462	HWY. 367	15	5.455
DIST. 7	5	BR. 03011	HWY. 79	7	7.771
DIST. 10	7	BR. 03083	HWY. 49	2	9.207
	8	BR. 03084	HWY. 49	2	8.699
	9	BR. 03085	HWY. 49	2	7.177
	10	BR. 03086	HWY. 49	2	6.177

C:\Users\jwheid\4/26/2022 12:55:56 PM
 WORKSPACE: AR001
 Y:\Projects\AR001_187919_012392-Hydrodemolition Bridge Preservation\Design\Civil\Drawings\012392_07_PM_001.dgn
 REVISED DATE: **REVIDATE**

DATE REVISED	DATE REVISED	FED. RD. DIST. NO.	STATE	JOB NO.	SHEET NO.	TOTAL SHEETS
		6	ARK.	012392	18	25
QUANTITIES						



4-26-22

**ADVANCE WARNING SIGNS AND DEVICES - DISTRICTS 2, 3, 5, 7, & 10
LANE CLOSURE FOR HYDRODEMOLITION BRIDGES**

SIGN NUMBER	DESCRIPTION	SIGN SIZE	STAGE 1	STAGE 2	MAXIMUM NUMBER REQUIRED	TOTAL SIGNS REQUIRED		VERTICAL PANELS	TRAFFIC DRUMS	FURNISHING AND INSTALLING PRECAST CONC. BARRIER	RELOCATING PRECAST CONC. BARRIER	PORTABLE TRAFFIC SIGNAL SYSTEM-ACTUATED	PORTABLE CHANGEABLE MESSAGE SIGN	
			LIN. FT. - EACH			NO.	SQ. FT.							EACH
ADVANCE WARNING SIGNS - HIGHWAY														
W20-1	ROAD WORK 1500 FT.	36"x36"	4	4	4	4	36.0							
W20-4	ONE LANE ROAD 1/2 MILE	36"x36"	4	4	4	4	36.0							
W20-4	ONE LANE ROAD 1000 FT.	36"x36"	4	4	4	4	36.0							
G20-2	END ROAD WORK	36"x18"	4	4	4	4	18.0							
W3-3	ADVANCED TRAFFIC CONTROL - TRAFFIC SIGNAL	30"x30"	4	4	4	4	25.0							
W3-4	BE PREPARED TO STOP	36"x36"	4	4	4	4	36.0							
W3-5	REDUCED SPEED LIMIT SIGN AHEAD	36"x36"	4	4	4	4	36.0							
R2-1	SPEED LIMIT	30"x36"	12	12	12	12	90.0							
R10-6	STOP HERE ON RED	24"x36"	4	4	4	4	24.0							
R4-1	DO NOT PASS	24"x30"	4	4	4	4	20.0							
W21-5a	RIGHT SHOULDER CLOSED	36"x36"	4	4	4	4	36.0							
W8-1	BUMP	30"x30"	4	4	4	4	25.0							
W8-11	UNEVEN LANES	48"x48"	4	4	4	4	64.0							
SUBTOTALS (DISTRICTS 2, 3, 5, 7, & 10 - ADVANCE WARNING SIGNS - HIGHWAY):							482.0							
ADVANCE DEVICES														
	VERTICAL PANELS		111	111	111			111						
	TRAFFIC DRUMS		111	111	111				111					
	FURNISHING AND INSTALLING PRECAST CONCRETE BARRIER		760		760					760				
	RELOCATING PRECAST CONCRETE BARRIER			760	760						760			
	PORTABLE TRAFFIC SIGNAL SYSTEM-ACTUATED				90							90		
	PORTABLE CHANGEABLE MESSAGE SIGN				65								65	
SUBTOTALS (DISTRICT 2, 3, 5, 7, & 10 - ADVANCE DEVICES):									111	111	760	760	90	65
PROJECT TOTALS (DISTRICTS 2, 3, 5, 7, & 10):							482.0		111	111	760	760	90	65

NOTES: MAINTENANCE OF TRAFFIC ITEMS ARE TO BE RELOCATED BETWEEN BRIDGE SITES AND DISTRICTS IF AND WHERE DIRECTED BY THE ENGINEER, THE TOTALS REPRESENT AN ESTIMATED QUANTITY AND TIME USAGE.

THERE ARE BOTH HIGH AND LOW TRAFFIC VOLUME LOCATIONS IN DISTRICTS 2, 3, 5, 7, & 10 AS DEFINED IN SECTION 604.03, STANDARD SPECIFICATIONS FOR HIGHWAY CONSTRUCTION. REFER TO PERMANENT PAVEMENT MARKING DETAILS FOR LIST OF HIGH AND LOW TRAFFIC VOLUMES IN EACH DISTRICT.

FURNISHING AND INSTALLING PRECAST BARRIER WALL AND RELOCATION QUANTITIES ARE PROVIDED TO BE USED IF AND WHERE DIRECTED BY THE ENGINEER FOR BACKWALL REPAIR ON BR. # 6 - 03253.

THE PORTABLE TRAFFIC SIGNAL QUANTITY IS BASED ON THE TIME FOR EACH OF THE TWO SIGNALS AT A BRIDGE SITE. IF SEVERAL BRIDGE SITES ARE BEING WORKED CONCURRENTLY, THE "WEEK" QUANTITY IS BASED ON A SUM OF EACH SIGNAL USED.

QUANTITIES ESTIMATED.
SEE SECTION 104.03 OF THE STD SPECS.

C:\Users\lshid\4/26/2022 12:55:57 PM
 WORKSPACE: AR001
 Y:\Projects\AR001\8799_012392_Hydrodemolition Bridge Preservation\Design\Civil - Bridge Only\Drawings\012392_08_01Y_001.dgn
 REVISED DATE: **REVIDATE**

DATE REVISED	DATE REVISED	FED. RD. DIST. NO.	STATE	JOB NO.	SHEET NO.	TOTAL SHEETS
06-07-22		6	ARK.	012392	19	25
QUANTITIES						



COLD MILLING ASPHALT PAVEMENT - DIST. 3 (BOX 1 OF 3)

BR. ID # (TITLE SHEET)	BRIDGE STRUCTURE NO.	ROUTE	LOG MILE	LOCATION	* AVG. DEPTH OF ASPHALT	LENGTH	AVG. WIDTH		COLD MILLING ASPHALT PAVEMENT
					INCHES		FEET	FEET	
2	02735	26	11.726	BR. DECK	2	152.25	24		406.00
				TRANSITION	2	200.00	22		488.89
SUBTOTAL (DIST. 3):									894.89

*AVERAGE DEPTH OF ASPHALT IS ESTIMATED AND SHOWN FOR INFORMATION ONLY. IF THE FIELD DEPTH OF ASPHALT ON THE DECK IS DETERMINED TO BE THICKER THAN THE DEPTH SHOWN, NO ADDITIONAL PAYMENT WILL BE MADE FOR GREATER DEPTHS.

COLD MILLING ASPHALT PAVEMENT - DIST. 5 (BOX 2 OF 3)

BR. ID # (TITLE SHEET)	BRIDGE STRUCTURE NO.	ROUTE	LOG MILE	LOCATION	* AVG. DEPTH OF ASPHALT	LENGTH	AVG. WIDTH		COLD MILLING ASPHALT PAVEMENT
					INCHES		FEET	FEET	
3	01446	367	8.028	BR. DECK	2	50.00	27		150.00
				TRANSITION	2	200.00	22		488.89
SUBTOTAL (DIST. 5):									638.89

*AVERAGE DEPTH OF ASPHALT IS ESTIMATED AND SHOWN FOR INFORMATION ONLY. IF THE FIELD DEPTH OF ASPHALT ON THE DECK IS DETERMINED TO BE THICKER THAN THE DEPTH SHOWN, NO ADDITIONAL PAYMENT WILL BE MADE FOR GREATER DEPTHS.

COLD MILLING ASPHALT PAVEMENT - DIST. 10 (BOX 3 OF 3)

BR. ID # (TITLE SHEET)	BRIDGE STRUCTURE NO.	ROUTE	LOG MILE	LOCATION	* AVG. DEPTH OF ASPHALT	LENGTH	AVG. WIDTH		COLD MILLING ASPHALT PAVEMENT
					INCHES		FEET	FEET	
6	03253	115	16.045	BR. DECK	2	50.00	24		133.33
				TRANSITION	2	100.00	22		244.44
7	03083	49	9.207	BR. DECK	2	75.00	28		233.33
				TRANSITION	2	200.00	24		533.33
8	03084	49	8.699	BR. DECK	2	75.00	28		233.33
				TRANSITION	2	200.00	24		533.33
9	03085	49	7.177	BR. DECK	2	75.00	28		233.33
				TRANSITION	2	200.00	24		533.33
10	03086	49	6.177	BR. DECK	2	75.00	28		233.33
				TRANSITION	2	200.00	24		533.33
SUBTOTAL (DIST. 10):									3444.41

*AVERAGE DEPTH OF ASPHALT IS ESTIMATED AND SHOWN FOR INFORMATION ONLY. IF THE FIELD DEPTH OF ASPHALT ON THE DECK IS DETERMINED TO BE THICKER THAN THE DEPTH SHOWN, NO ADDITIONAL PAYMENT WILL BE MADE FOR GREATER DEPTHS. BR. NO. 6 - 03253 HAS ASPHALT OVERLAY ON THE EASTERN SIDE OF BRIDGE DECK. QUANTITY IF AND WHERE DIRECTED BY THE ENGINEER.

SUBTOTALS DIST. 3 - (BOX 1 OF 3):	894.89
SUBTOTALS DIST. 5 - (BOX 2 OF 3):	638.89
SUBTOTALS DIST. 10 - (BOX 3 OF 3):	3444.41
PROJECT TOTALS:	4978.19

*AVERAGE DEPTH OF ASPHALT IS ESTIMATED AND SHOWN FOR INFORMATION ONLY. IF THE FIELD DEPTH OF ASPHALT ON THE DECK IS DETERMINED TO BE THICKER THAN THE DEPTH SHOWN, NO ADDITIONAL PAYMENT WILL BE MADE FOR GREATER DEPTHS.

COORDINATE COLD MILLING STOCKPILE LOCATIONS WITH DISTRICT ENGINEER. STOCKPILE LOCATIONS SHALL BE NO FURTHER THAN FIVE MILES FROM EACH SITE.

BASE AND SURFACING - MAIN LANE TRANSITIONS - DIST. 3 (BOX 1 OF 3)

BR. ID # (TITLE SHEET)	BR. STRUCTURE NO.	ROUTE	LOG MILE	LOCATION	LENGTH FEET	TACK COAT		ACHM SURFACE COURSE (1/2")				
						(0.17 GAL. PER SQ. YD.)		TOTAL GALLONS	TOTAL WID. FEET	SQ. YD.	POUND / SQ. YD.	TOTAL PG 64-22 TON
						FEET	SQ. YD.					
2	02735	26	11.726	MAIN LANE TRANSITION	200.00	22	977.78	166.22	22	977.78	220	107.56
SUBTOTALS (DIST. 3):								166.22	22	977.78	220	107.56

BASIS OF ESTIMATE (DIST. 3)
ACHM SURFACE COURSE (1/2").....94.8% MIN. AGGR.....5.2% ASPHALT BINDER

MAXIMUM NUMBER OF GYRATIONS = 115 FOR PG 64-22
TACK COAT QUANTITIES WERE CALCULATED USING THE EMULSIFIED ASPHALT RATES. REFER TO SS-400-1 FOR THE RESIDUAL ASPHALT APPLICATION RATES.

BASE AND SURFACING - MAIN LANE TRANSITIONS - DIST. 5 (BOX 2 OF 3)

BR. ID # (TITLE SHEET)	BR. STRUCTURE NO.	ROUTE	LOG MILE	LOCATION	LENGTH FEET	TACK COAT		ACHM SURFACE COURSE (1/2")				
						(0.17 GAL. PER SQ. YD.)		TOTAL GALLONS	TOTAL WID. FEET	SQ. YD.	POUND / SQ. YD.	TOTAL PG 64-22 TON
						FEET	SQ. YD.					
3	01446	367	8.028	MAIN LANE TRANSITION	200.00	22	977.78	166.22	22	977.78	220	107.56
SUBTOTALS (DIST. 5):								166.22	22	977.78	220	107.56

BASIS OF ESTIMATE (DIST. 5)
ACHM SURFACE COURSE (1/2").....94.7% MIN. AGGR.....5.3% ASPHALT BINDER

MAXIMUM NUMBER OF GYRATIONS = 115 FOR PG 64-22
TACK COAT QUANTITIES WERE CALCULATED USING THE EMULSIFIED ASPHALT RATES. REFER TO SS-400-1 FOR THE RESIDUAL ASPHALT APPLICATION RATES.

BASE AND SURFACING - MAIN LANE TRANSITIONS - DIST. 10 (BOX 3 OF 3)

BR. ID # (TITLE SHEET)	BR. STRUCTURE NO.	ROUTE	LOG MILE	LOCATION	LENGTH FEET	TACK COAT		ACHM SURFACE COURSE (1/2")				
						(0.17 GAL. PER SQ. YD.)		TOTAL GALLONS	TOTAL WID. FEET	SQ. YD.	POUND / SQ. YD.	TOTAL PG 64-22 TON
						FEET	SQ. YD.					
6	03253	115	16.045	MAIN LANE TRANSITION	100.00	22	244.44	41.55	22	244.44	220	26.89
7	03083	49	9.207	MAIN LANE TRANSITION	200.00	24	1066.67	181.33	24	1066.67	220	117.33
8	03084	49	8.699	MAIN LANE TRANSITION	200.00	24	1066.67	181.33	24	1066.67	220	117.33
9	03085	49	7.177	MAIN LANE TRANSITION	200.00	24	1231.68	209.39	24	1231.68	220	135.48
10	03086	49	6.177	MAIN LANE TRANSITION	200.00	24	1066.67	181.33	24	1066.67	220	117.33
SUBTOTALS (DIST. 10):								794.93	24	1066.67	220	514.36

BASIS OF ESTIMATE (DIST. 10)
ACHM SURFACE COURSE (1/2").....94.9% MIN. AGGR.....5.1% ASPHALT BINDER

MAXIMUM NUMBER OF GYRATIONS = 115 FOR PG 64-22
TACK COAT QUANTITIES WERE CALCULATED USING THE EMULSIFIED ASPHALT RATES. REFER TO SS-400-1 FOR THE RESIDUAL ASPHALT APPLICATION RATES.

SUBTOTALS DIST. 3 - (BOX 1 OF 3):	166.22			107.56
SUBTOTALS DIST. 5 - (BOX 2 OF 3):	166.22			107.56
SUBTOTALS DIST. 10 - (BOX 3 OF 3):	794.93			514.36
PROJECT TOTALS:	1127.37			729.48

T:\civil\kay\pcc\6/16/2022 8:51:16 AM
WORKSPACE\AR001\B7919_012392_Hydrodemolition Bridge Preservation\Design\Civil - Bridge Only\Drawings\AR012392_08_0TY_001.dgn
Y:\Projects\AR001\B7919_012392_Hydrodemolition Bridge Preservation\Design\Civil - Bridge Only\Drawings\AR012392_08_0TY_001.dgn
REVISED DATE: **REVE DATE**

DATE REVISED	DATE REVISED	FED. RD. DIST. NO.	STATE	JOB NO.	SHEET NO.	TOTAL SHEETS
		6	ARK.	012392	20	25
QUANTITIES						

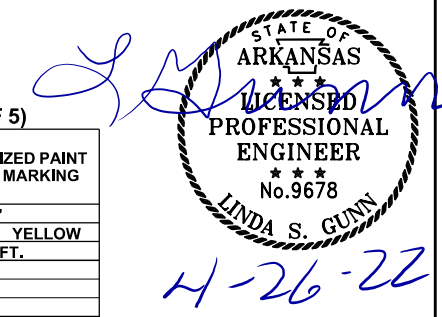

CONSTRUCTION PAVEMENT MARKINGS AND PERMANENT PAVEMENT MARKINGS - DIST. 2 (BOX 1 OF 5)

BR. ID # (TITLE SHEET)	BR. STRUCTURE NO.	ROUTE	LOG MILE	DESCRIPTION	REMOVABLE CONST. PAVEMENT MARKINGS	RAISED PAVEMENT MARKERS		THERMOPLASTIC PAVEMENT MARKING		REFLECTORIZED PAINT PAVEMENT MARKING	
						TYPE II		6"		6"	
						(YELLOW/YELLOW)		WHITE	YELLOW	WHITE	YELLOW
					LIN. FT.	LIN. FT.		LIN. FT.			
1	03384	1	1.551	WHITE	48		180		180		
				YELLOW	180						
				R.P.M.		1					
SUBTOTALS (DIST. 2):					228	1	180	180			

NOTE: 2 LANE ROAD HAS HIGH TRAFFIC VOLUME IN DISTRICT 2 AS DEFINED IN SECTION 604.03, STANDARD SPECIFICATIONS FOR HIGHWAY CONSTRUCTION. REFER TO PERMANENT PAVEMENT MARKING DETAILS FOR LIST OF HIGH AND LOW ROADS IN EACH DISTRICT.

FOR 2 LANE ROADS, THE 12" WHITE STOP BAR LIN. FT. QUANTITY FROM THE 2 LANE MAINTENANCE OF TRAFFIC DETAIL IS INCLUDED IN THE REMOVABLE CONSTRUCTION PAVEMENT MARKINGS COLUMN FOR STAGE 1 AND STAGE 2 CONSTRUCTION.

THE 6" YELLOW STRIPING QUANTITY HAS BEEN ESTIMATED BASED ON A DOUBLE YELLOW CENTERLINE STRIPE FOR THE ENTIRE PROJECT. THE PROJECT MUST BE MARKED FOR PASSING/NO PASSING ZONES PRIOR TO THE PLACEMENT OF ANY FINAL STRIPING. CONTACT THE MAINTENANCE DIVISION AFTER THE FINAL LIFT OF SURFACE COURSE HAS BEEN PLACED TO SCHEDULE THE ZONING OF THE PROJECT.

CONSTRUCTION PAVEMENT MARKINGS AND PERMANENT PAVEMENT MARKINGS - DIST. 3 (BOX 2 OF 5)

BR. ID # (TITLE SHEET)	BR. STRUCTURE NO.	ROUTE	LOG MILE	DESCRIPTION	REMOVABLE CONST. PAVEMENT MARKINGS	RAISED PAVEMENT MARKERS		THERMOPLASTIC PAVEMENT MARKING		REFLECTORIZED PAINT PAVEMENT MARKING	
						TYPE II		6"		6"	
						(YELLOW/YELLOW)		WHITE	YELLOW	WHITE	YELLOW
					LIN. FT.	LIN. FT.		LIN. FT.			
2	02735	26	11.726	WHITE	48				705		705
				YELLOW	705						
				R.P.M.		4					
SUBTOTALS (DIST. 3):					753	4			705	705	

NOTE: 2 LANE ROAD HAS LOW TRAFFIC VOLUME IN DISTRICT 3 AS DEFINED IN SECTION 604.03, STANDARD SPECIFICATIONS FOR HIGHWAY CONSTRUCTION. REFER TO PERMANENT PAVEMENT MARKING DETAILS FOR LIST OF HIGH AND LOW ROADS IN EACH DISTRICT.

FOR 2 LANE ROADS, THE 12" WHITE STOP BAR LIN. FT. QUANTITY FROM THE 2 LANE MAINTENANCE OF TRAFFIC DETAIL IS INCLUDED IN THE REMOVABLE CONSTRUCTION PAVEMENT MARKINGS COLUMN FOR STAGE 1 AND STAGE 2 CONSTRUCTION.

THE 6" YELLOW STRIPING QUANTITY HAS BEEN ESTIMATED BASED ON A DOUBLE YELLOW CENTERLINE STRIPE FOR THE ENTIRE PROJECT. THE PROJECT MUST BE MARKED FOR PASSING/NO PASSING ZONES PRIOR TO THE PLACEMENT OF ANY FINAL STRIPING. CONTACT THE MAINTENANCE DIVISION AFTER THE FINAL LIFT OF SURFACE COURSE HAS BEEN PLACED TO SCHEDULE THE ZONING OF THE PROJECT.

CONSTRUCTION PAVEMENT MARKINGS AND PERMANENT PAVEMENT MARKINGS - DIST. 5 (BOX 3 OF 5)

BR. ID # (TITLE SHEET)	BR. STRUCTURE NO.	ROUTE	LOG MILE	DESCRIPTION	REMOVABLE CONST. PAVEMENT MARKINGS	RAISED PAVEMENT MARKERS		THERMOPLASTIC PAVEMENT MARKING		REFLECTORIZED PAINT PAVEMENT MARKING	
						TYPE II		6"		6"	
						(YELLOW/YELLOW)		WHITE	YELLOW	WHITE	YELLOW
					LIN. FT.	LIN. FT.		LIN. FT.			
3	01446	367	8.028	WHITE	44				500		500
				YELLOW	500						
				R.P.M.		2					
4	01462	367	5.455	WHITE	44		362		362		
				YELLOW	362						
				R.P.M.		4					
SUBTOTALS (DIST. 5):					950	6	362	362	500	500	

NOTE: 2 LANE ROADS HAVE BOTH HIGH AND LOW TRAFFIC VOLUME IN DISTRICT 5 AS DEFINED IN SECTION 604.03, STANDARD SPECIFICATIONS FOR HIGHWAY CONSTRUCTION. REFER TO PERMANENT PAVEMENT MARKING DETAILS FOR LIST OF HIGH AND LOW ROADS IN EACH DISTRICT.

FOR 2 LANE ROADS, THE 12" WHITE STOP BAR LIN. FT. QUANTITY FROM THE 2 LANE MAINTENANCE OF TRAFFIC DETAIL IS INCLUDED IN THE REMOVABLE CONSTRUCTION PAVEMENT MARKINGS COLUMN FOR STAGE 1 AND STAGE 2 CONSTRUCTION.

THE 6" YELLOW STRIPING QUANTITY HAS BEEN ESTIMATED BASED ON A DOUBLE YELLOW CENTERLINE STRIPE FOR THE ENTIRE PROJECT. THE PROJECT MUST BE MARKED FOR PASSING/NO PASSING ZONES PRIOR TO THE PLACEMENT OF ANY FINAL STRIPING. CONTACT THE MAINTENANCE DIVISION AFTER THE FINAL LIFT OF SURFACE COURSE HAS BEEN PLACED TO SCHEDULE THE ZONING OF THE PROJECT.

CONSTRUCTION PAVEMENT MARKINGS AND PERMANENT PAVEMENT MARKINGS - DIST. 7 (BOX 4 OF 5)

BR. ID # (TITLE SHEET)	BR. STRUCTURE NO.	ROUTE	LOG MILE	DESCRIPTION	REMOVABLE CONST. PAVEMENT MARKINGS	RAISED PAVEMENT MARKERS		THERMOPLASTIC PAVEMENT MARKING		REFLECTORIZED PAINT PAVEMENT MARKING	
						TYPE II		6"		6"	
						(YELLOW/YELLOW)		WHITE	YELLOW	WHITE	YELLOW
					LIN. FT.	LIN. FT.		LIN. FT.			
5	03011	79	7.771	WHITE	44			4026	4026		
				YELLOW	4026						
				R.P.M.		26					
SUBTOTALS (DIST. 7):					4070	26	4026	4026			

NOTE: 2 LANE ROAD HAS HIGH TRAFFIC VOLUME IN DISTRICT 2 AS DEFINED IN SECTION 604.03, STANDARD SPECIFICATIONS FOR HIGHWAY CONSTRUCTION. REFER TO PERMANENT PAVEMENT MARKING DETAILS FOR LIST OF HIGH AND LOW ROADS IN EACH DISTRICT.

FOR 2 LANE ROADS, THE 12" WHITE STOP BAR LIN. FT. QUANTITY FROM THE 2 LANE MAINTENANCE OF TRAFFIC DETAIL IS INCLUDED IN THE REMOVABLE CONSTRUCTION PAVEMENT MARKINGS COLUMN FOR STAGE 1 AND STAGE 2 CONSTRUCTION.

THE 6" YELLOW STRIPING QUANTITY HAS BEEN ESTIMATED BASED ON A DOUBLE YELLOW CENTERLINE STRIPE FOR THE ENTIRE PROJECT. THE PROJECT MUST BE MARKED FOR PASSING/NO PASSING ZONES PRIOR TO THE PLACEMENT OF ANY FINAL STRIPING. CONTACT THE MAINTENANCE DIVISION AFTER THE FINAL LIFT OF SURFACE COURSE HAS BEEN PLACED TO SCHEDULE THE ZONING OF THE PROJECT.

CONSTRUCTION PAVEMENT MARKINGS AND PERMANENT PAVEMENT MARKINGS - DIST. 10 (BOX 5 OF 5)

BR. ID # (TITLE SHEET)	BR. STRUCTURE NO.	ROUTE	LOG MILE	DESCRIPTION	REMOVABLE CONST. PAVEMENT MARKINGS	RAISED PAVEMENT MARKERS		THERMOPLASTIC PAVEMENT MARKING		REFLECTORIZED PAINT PAVEMENT MARKING	
						TYPE II		6"		6"	
						(YELLOW/YELLOW)		WHITE	YELLOW	WHITE	YELLOW
					LIN. FT.	LIN. FT.		LIN. FT.			
6	03253	115	16.045	WHITE	48				1400		1400
				YELLOW	1400						
				R.P.M.		10					
7	03083	49	9.207	WHITE	48			550	550		
				YELLOW	550						
				R.P.M.		2					
8	03084	49	8.699	WHITE	48			550	550		
				YELLOW	550						
				R.P.M.		2					
9	03085	49	7.177	WHITE	48			550	550		
				YELLOW	550						
				R.P.M.		2					
10	03086	49	6.177	WHITE	48			550	550		
				YELLOW	550						
				R.P.M.		3					
SUBTOTALS (DIST. 10):					3840	19	2200	2200	1400	1400	

NOTE: 2 LANE ROADS HAVE BOTH HIGH AND LOW TRAFFIC VOLUME IN DISTRICT 2 AS DEFINED IN SECTION 604.03, STANDARD SPECIFICATIONS FOR HIGHWAY CONSTRUCTION. REFER TO PERMANENT PAVEMENT MARKING DETAILS FOR LIST OF HIGH AND LOW ROADS IN EACH DISTRICT.

FOR 2 LANE ROADS, THE 12" WHITE STOP BAR LIN. FT. QUANTITY FROM THE 2 LANE MAINTENANCE OF TRAFFIC DETAIL IS INCLUDED IN THE REMOVABLE CONSTRUCTION PAVEMENT MARKINGS COLUMN FOR STAGE 1 AND STAGE 2 CONSTRUCTION.

THE 6" YELLOW STRIPING QUANTITY HAS BEEN ESTIMATED BASED ON A DOUBLE YELLOW CENTERLINE STRIPE FOR THE ENTIRE PROJECT. THE PROJECT MUST BE MARKED FOR PASSING/NO PASSING ZONES PRIOR TO THE PLACEMENT OF ANY FINAL STRIPING. CONTACT THE MAINTENANCE DIVISION AFTER THE FINAL LIFT OF SURFACE COURSE HAS BEEN PLACED TO SCHEDULE THE ZONING OF THE PROJECT.

SUBTOTALS DIST. 2 - (BOX 1 OF 5):	228	1	180	180		
SUBTOTALS DIST. 3 - (BOX 2 OF 5):	753	4			705	705
SUBTOTALS DIST. 5 - (BOX 3 OF 5):	950	6	362	362	500	500
SUBTOTALS DIST. 7 - (BOX 4 OF 5):	4070	26	4026	4026		
SUBTOTALS DIST. 10 - (BOX 5 OF 5):	3840	19	2200	2200	1400	1400
PROJECT TOTALS:	9841	56	6768	6768	2605	2605

C:\Users\jweld\OneDrive\Documents\2022\04\26\2022 12:55:59 PM
 WORKSPACE: AR001_8799_012392_Hydrodemolition Bridge Preservation\Design\Civil - Bridge Only\Drawings\012392_08_01Y_001.dgn
 Y:\Projects\AR001_8799_012392_Hydrodemolition Bridge Preservation\Design\Civil - Bridge Only\Drawings\012392_08_01Y_001.dgn
 REVISED DATE: **REVE DATE**

DATE REVISED	DATE FILMED	DATE REVISED	DATE FILMED	FED. RD. DIST. NO.	STATE	FED. AID PROJ. NO.	SHEET NO.	TOTAL SHEETS
06-07-22				6	ARK.			
				JOB NO.	012392	21	25	

① DISTRICTS 2, 3, 5, 7, & 10 BRIDGES - QUANTITIES - 65175

SCHEDULE OF BRIDGE QUANTITIES - JOB NO. 012392

DISTRICT	SITE NO.	COUNTY	ROUTE	SECTION	LOG MILE	BRIDGE NO.	SP & 509	SS & 802	SP & 803	SP & 803	SS & 804	SS & 809	821	SP JOB 012392	SP JOB 012392	SP JOB 012392	SP JOB 012392	SP JOB 012392	SP JOB 012392
							JOINT REHABILITATION (TYPE A)	GROOVING	CLASS 1 PROTECTIVE SURFACE TREATMENT	CLASS 3 PROTECTIVE SURFACE TREATMENT	REINFORCING STEEL-BRIDGE (GRADE 60)	SILICONE JOINT SEALANT	MODIFICATION OF EXISTING BRIDGE STRUCTURE (BRIDGE NO. _____)	BRIDGE DECK REPAIR FOR LATEX MODIFIED CONCRETE OVERLAYS	HYDRODEMOLITION - CLASS 2	LATEX MODIFIED CONCRETE OVERLAY (1 1/2" THICK)	RAILING REPAIR	SPALL REPAIR	SURFACE PATCHING
							LIN. FT.	SQ. YD.	GAL.	LIN. FT.	POUND	LIN. FT.	LUMP SUM	SQ. FT.	SQ. YD.	SQ. YD.	LUMP SUM	SQ. FT.	SQ. FT.
2	1	ARKANSAS	HWY. 1	4	1.551	03384 ②③	65	250.0	5.6	180	220			252	280	281		10	5
TOTALS FOR DISTRICT 2							65	250.0	5.6	180	220			252	280	281		10	5
3	2	PIKE	HWY. 26	3	11.726	02735 ①		350.0	8.0	300	310	98 ⑥		360	400	402		5	5
TOTALS FOR DISTRICT 3								350.0	8.0	300	310	98		360	400	402		5	5
5	3	WHITE	HWY. 367	15	8.028	01446 ①	27	134.0	3.0	100	120			135	150	151		60	10
	4	WHITE	HWY. 367	15	5.455	01462 ②	96	423.0	9.7	362	370			435	483	485		70	10
TOTALS FOR DISTRICT 5							123	557.0	12.7	462	490			570	633	636		130	20
7	5	CLEVELAND	HWY. 79	7	7.771	03011 ②③		5,140.0	116.0	4,023	4,450	1,325 ⑥⑦		5,229	5,810	5,829		140	70
TOTALS FOR DISTRICT 7								5,140.0	116.0	4,023	4,450	1,325		5,229	5,810	5,829		140	70
10	6	LAWRENCE	HWY. 115	2	16.045	03253 ③④		1,629.0	37.2	1,396	1,430	441 ⑥⑦	1 ⑧	1,676	1,862	1,868		50	15
	7	GREENE	HWY. 49	2	9.207	03083 ①	56	209.0	4.7	150	180			210	234	235		5	5
	8	GREENE	HWY. 49	2	8.699	03084 ①	56	209.0	4.7	150	180			210	234	235		60	10
	9	GREENE	HWY. 49	2	7.177	03085 ①	65	209.0	4.7	150	180			210	234	235		25	20
	10	GREENE	HWY. 49	2	6.177	03086 ①	56	209.0	4.7	150	180			210	234	235	1	15	5
TOTALS FOR DISTRICT 10							233	2,465.0	56.0	1,996	2,150	441		2,516	2,798	2,808		155	55
TOTALS FOR JOB 012392							421	8,762.0	198.3	6,961	7,620 ⑤	1,864		8,927 ⑤	9,921	9,956		440 ⑤	155 ⑤

REFERENCE TABLE

BRIDGE NO.	EXISTING DWG. NO(S).
03384	11028, 5422B
02735	7812, 5193, 5198
01446	2866, 2353
01462	2762, 2329
03011	8936A-8936E, 5453, 5454, 5456
03253	10019, 10019A, 5500, 5500A, 5500P
03083	10826, 5475
03084	10827, 5475
03085	10828, 5475, 5475B
03086	10829, 5475

- ① EXISTING BRIDGE DECK HAS AN ASPHALT OVERLAY. SEE ROADWAY PLANS FOR AVERAGE DEPTH AT EACH BRIDGE SITE.
- ② EXISTING BRIDGE DECK HAS NO ASPHALT OVERLAY.
- ③ EXISTING BRIDGE DECK HAS SPALLS FILLED WITH ASPHALT.
- ④ EXISTING BRIDGE DECK HAS AN ASPHALT OVERLAY ON BEGINNING AND END SPANS.
- ⑤ QUANTITY SHOWN IS FOR ESTIMATING AND BIDDING PURPOSES ONLY. ACTUAL QUANTITY, IF ANY, WILL BE DETERMINED IN THE FIELD.
- ⑥ EXISTING BRIDGE HAS SLIDER PLATE JOINTS TO BE PARTIALLY REMOVED AND REPLACED WITH POURED SILICONE JOINTS.
- ⑦ EXISTING BRIDGE HAS FILLED JOINTS TO BE REMOVED AND REPLACED WITH POURED SILICONE JOINTS.
- ⑧ MODIFICATION OF EXISTING BRIDGE STRUCTURE INCLUDES REPAIR OF BACKWALLS TO MATCH TOP SURFACE OF FINISHED LMC OVERLAY WITH GRADE RAISE ON ADJACENT BRIDGE DECK. SEE STANDARD DRAWING NO. 55065.



**SCHEDULE OF BRIDGE QUANTITIES
HYDRODEMOLITION BRIDGE
PRESERVATION (2022) (S)
VARIOUS COUNTIES
ROUTE VARIES SECTION VARIES
ARKANSAS STATE HIGHWAY COMMISSION
LITTLE ROCK, ARKANSAS**

BRIDGE ENGINEER: Ethan R. B. Baker DRAWN BY: ERBB DATE: 02/2022 FILENAME: B012392_Q1.dgn
 PRINT DATE: 6/6/2022 CHECKED BY: MKL DATE: 03/2022 DESIGNED BY: ERBB DATE: 02/2022 SCALE: NO SCALE
 BRIDGE NO. DISTRICTS 2, 3, 5, 7, & 10 BRIDGES DRAWING NO. 65175

Travels Keymer 6/6/2022 11:04:05 AM
 WORKSPACE: ABDOT
 Y:\Projects\ARADOT_187919_012392_Hydrodemolition Bridge Preservation\Design\BRIDGE - wo AG\Drawings\B012392_Q1.dgn
 REVISED DATE:

DATE REVISED	DATE REVISED	FED. RD. DIST. NO.	STATE	JOB NO.	SHEET NO.	TOTAL SHEETS
06-07-22		6	ARK.	012392	22	25
SUMMARY OF QUANTITIES AND REVISIONS						

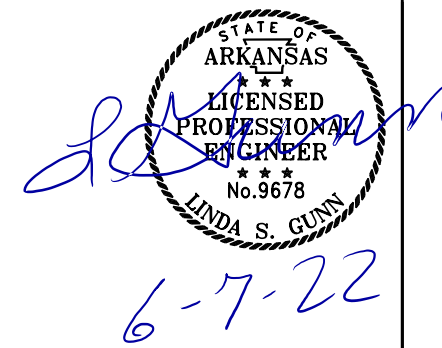

SUMMARY OF QUANTITIES

ITEM NUMBER	ITEM	DIST. 2 QUANTITIES	DIST. 3 QUANTITIES	DIST. 5 QUANTITIES	DIST. 7 QUANTITIES	DIST. 10 QUANTITIES	PROJECT TOTAL QUANTITIES	UNIT
SS & 401	TACK COAT		166	166		795	1127	GAL.
SP, SS, & 407	MINERAL AGGREGATE IN ACHM SURFACE COURSE (1/2")		102	102		488	692	TON
SP, SS, & 407	ASPHALT BINDER (PG 64-22) IN ACHM SURFACE COURSE (1/2")		6	6		26	38	TON
SP & 412	COLD MILLING ASPHALT PAVEMENT		895	639		3444	4978	SQ. YD.
601	MOBILIZATION	0.04	0.05	0.07	0.55	0.29	1.00	LUMP SUM
SP, SS, & 603	MAINTENANCE OF TRAFFIC	0.04	0.05	0.07	0.55	0.29	1.00	LUMP SUM
SS & 604	SIGNS						482	SQ. FT.
SS & 604	TRAFFIC DRUMS						111	EACH
SS & 604	FURNISHING AND INSTALLING PRECAST CONCRETE BARRIER						760	LIN. FT.
SS & 604	RELOCATING PRECAST CONCRETE BARRIER						760	LIN. FT.
604	REMOVABLE CONSTRUCTION PAVEMENT MARKINGS	228	753	950	4070	3840	9841	LIN. FT.
SP, SS, & 604	PORTABLE CHANGEABLE MESSAGE SIGN						65	WEEK
SS & 604	VERTICAL PANELS						111	EACH
635	ROADWAY CONSTRUCTION CONTROL	0.04	0.05	0.07	0.55	0.29	1.00	LUMP SUM
SP	PORTABLE TRAFFIC SIGNAL SYSTEM - ACTUATED						90	WEEK
718	REFLECTORIZED PAINT PAVEMENT MARKING WHITE (6")		705	500		1400	2605	LIN. FT.
718	REFLECTORIZED PAINT PAVEMENT MARKING YELLOW (6")		705	500		1400	2605	LIN. FT.
719	THERMOPLASTIC PAVEMENT MARKING WHITE (6")	180		362	4026	2200	6768	LIN. FT.
719	THERMOPLASTIC PAVEMENT MARKING YELLOW (6")	180		362	4026	2200	6768	LIN. FT.
721	RAISED PAVEMENT MARKERS (TYPE II)	1	4	6	26	19	56	EACH
STRUCTURES OVER 20' SPAN								
SP & 509	JOINT REHABILITATION (TYPE A)	65		123		233	421	LIN. FT.
636	BRIDGE CONSTRUCTION CONTROL	0.04	0.05	0.07	0.55	0.29	1.00	LUMP SUM
SS & 802	GROOVING	250.0	350.0	557.0	5140.0	2465.0	8762.0	SQ. YD.
SP & 803	CLASS 1 PROTECTIVE SURFACE TREATMENT	5.6	8.0	12.7	116.0	56	198.3	GAL.
SP & 803	CLASS 3 PROTECTIVE SURFACE TREATMENT	180	300	462	4023	1996	6961	LIN. FT.
SS & 804	REINFORCING STEEL-BRIDGE (GRADE 60)	220	310	490	4450	2150	7620	POUND
SS & 809	SILICONE JOINT SEALANT		98		1325	441	1864	LIN. FT.
821	MODIFICATION OF EXISTING BRIDGE STRUCTURE (BRIDGE NO. 03253)					1.00	1.00	LUMP SUM
SP	BRIDGE DECK REPAIR FOR LATEX MODIFIED CONCRETE OVERLAYS	252	360	570	5229	2516	8927	SQ. FT.
SP	HYDRODEMOLITION - CLASS 2	280	400	633	5810	2798	9921	SQ. YD.
SP	LATEX MODIFIED CONCRETE OVERLAY (1 1/2" THICK)	281	402	636	5829	2808	9956	SQ. YD.
SP	RAILING REPAIR					1.00	1.00	LUMP SUM
SP	SPALL REPAIR	10	5	130	140	155	440	SQ. FT.
SP	SURFACE PATCHING	5	5	20	70	55	155	SQ. FT.

REVISIONS

DATE	REVISION	SHEET NUMBER
06/07/2022	REVISED FAP NUMBER. REVISED GOVERNING SPECIFICATIONS. ADDED STOCKPILE LOCATION NOTE TO COLD MILLING QUANTITY BOX. REMOVED LUMP SUM TOTAL QUANTITY FOR 'RAILING REPAIR' FROM JOB TOTAL. REVISED NUMBER OF DECIMAL PLACES SHOWN FOR 'RAILING REPAIR' QUANTITY.	1, 4, 19, 21, & 22

T:\civil\kay\ref - 6/6/2022 11:25:26 AM
 WORKSPACE: AR001
 Y:\Projects\AR001\8799_012392_Hydrodemolition Bridge Preservation\Design\Civil - Bridge Only\Drawings\012392_08_0TY_001.dgn
 REVISED DATE: **REDATE**

DATE REVISED	DATE FILMED	DATE REVISED	DATE FILMED	FED. RD. DIST. NO.	STATE	FED. AID PROJ. NO.	SHEET NO.	TOTAL SHEETS
				6	ARK.			
				JOB NO.		012392	23	25

① DISTRICTS 2, 3, 5, 7, & 10 BRIDGES - BRIDGE DATA - 65176

**BRIDGE PRESERVATION DATA TABLE
(DISTRICT 2)**

CURRENT CONST. CONTRACT SITE NO.	BRIDGE NO.	ORIGINAL CONTRACT NO.	COUNTY	ROUTE	SECTION	SUPERSTRUCTURE TYPE	DECK TREATMENT TYPE	DECK TREATMENT STD. DRAWINGS	GRADE RAISE NEEDED FOR LMC OVERLAY?	BRIDGE JOINT TREATMENT STD. DRAWING	BRIDGE JOINT TREATMENT LOCATION
1	03384	2599	ARKANSAS	HWY. 1	4	VOIDED CONCRETE SLAB	HYDRODEMOLITION	55063	NO	NO STD. DWG. - USE TYPE A JOINT REHAB AND SP. SEE ROADWAY SPECIAL DETAILS.	BENTS 2 & 3

**BRIDGE PRESERVATION DATA TABLE
(DISTRICT 3)**

CURRENT CONST. CONTRACT SITE NO.	BRIDGE NO.	ORIGINAL CONTRACT NO.	COUNTY	ROUTE	SECTION	SUPERSTRUCTURE TYPE	DECK TREATMENT TYPE	DECK TREATMENT STD. DRAWINGS	GRADE RAISE NEEDED FOR LMC OVERLAY?	BRIDGE JOINT TREATMENT STD. DRAWING	BRIDGE JOINT TREATMENT LOCATION
2	02735	3407	PIKE	HWY. 26	3	STEEL I-BEAM	HYDRODEMOLITION	55060	NO	55064	BENTS 1-4

**BRIDGE PRESERVATION DATA TABLE
(DISTRICT 5)**

CURRENT CONST. CONTRACT SITE NO.	BRIDGE NO.	ORIGINAL CONTRACT NO.	COUNTY	ROUTE	SECTION	SUPERSTRUCTURE TYPE	DECK TREATMENT TYPE	DECK TREATMENT STD. DRAWINGS	GRADE RAISE NEEDED FOR LMC OVERLAY?	BRIDGE JOINT TREATMENT STD. DRAWING	BRIDGE JOINT TREATMENT LOCATION
3	01446	595	WHITE	HWY. 367	15	RCDG	HYDRODEMOLITION	55062	NO	NO STD. DWG. - USE TYPE A JOINT REHAB AND SP. SEE ROADWAY SPECIAL DETAILS.	BENT 2
4	01462	595	WHITE	HWY. 367	15	RCDG	HYDRODEMOLITION	55062	NO	NO STD. DWG. - USE TYPE A JOINT REHAB AND SP. SEE ROADWAY SPECIAL DETAILS.	BENTS 2-5

**BRIDGE PRESERVATION DATA TABLE
(DISTRICT 7)**

CURRENT CONST. CONTRACT SITE NO.	BRIDGE NO.	ORIGINAL CONTRACT NO.	COUNTY	ROUTE	SECTION	SUPERSTRUCTURE TYPE	DECK TREATMENT TYPE	DECK TREATMENT STD. DRAWINGS	GRADE RAISE NEEDED FOR LMC OVERLAY?	BRIDGE JOINT TREATMENT STD. DRAWING	BRIDGE JOINT TREATMENT LOCATION
5	03011	2505	CLEVELAND	HWY. 79	7	STEEL I-BEAM	HYDRODEMOLITION	55060	NO	55064	BENTS 1-48 & PIERS 1-2

**BRIDGE PRESERVATION DATA TABLE
(DISTRICT 10)**

CURRENT CONST. CONTRACT SITE NO.	BRIDGE NO.	ORIGINAL CONTRACT NO.	COUNTY	ROUTE	SECTION	SUPERSTRUCTURE TYPE	DECK TREATMENT TYPE	DECK TREATMENT STD. DRAWINGS	GRADE RAISE NEEDED FOR LMC OVERLAY?	BRIDGE JOINT TREATMENT STD. DRAWING	BRIDGE JOINT TREATMENT LOCATION
6	03253	10638	LAWRENCE	HWY. 115	2	STEEL I-BEAM	HYDRODEMOLITION	55061	YES	55064 & 55065	BENTS 1 & 16 (BOTH WITH BACKWALL REPAIR), BENTS 2-15, & PIERS 1-2
7	03083	10581	GREENE	HWY. 49	2	R.C. SLAB	HYDRODEMOLITION	55062	NO	NO STD. DWG. - USE TYPE A JOINT REHAB AND SP. SEE ROADWAY SPECIAL DETAILS.	BENTS 2 & 3
8	03084	10581	GREENE	HWY. 49	2	R.C. SLAB	HYDRODEMOLITION	55062	NO	NO STD. DWG. - USE TYPE A JOINT REHAB AND SP. SEE ROADWAY SPECIAL DETAILS.	BENTS 2 & 3
9	03085	10581	GREENE	HWY. 49	2	R.C. SLAB	HYDRODEMOLITION	55062	NO	NO STD. DWG. - USE TYPE A JOINT REHAB AND SP. SEE ROADWAY SPECIAL DETAILS.	BENTS 2 & 3
10	03086	10581	GREENE	HWY. 49	2	R.C. SLAB	HYDRODEMOLITION	55062	NO	NO STD. DWG. - USE TYPE A JOINT REHAB AND SP. SEE ROADWAY SPECIAL DETAILS.	BENTS 2 & 3



**BRIDGE PRESERVATION DATA TABLE
DISTRICTS 2, 3, 5, 7, & 10**
ROUTE VARIES SECTION VARIES
ARKANSAS STATE HIGHWAY COMMISSION
LITTLE ROCK, ARKANSAS

BRIDGE ENGINEER: ERBB
PRINT DATE: 4/26/2022
CHECKED BY: SFH
DESIGNED BY: ERBB
DATE: 02/2022
DATE: 03/2022
DATE: 02/2022
FILE NAME: 8012392_DT2,3,5,7,10.dgn
SCALE: NO SCALE
DRAWING NO. 65176

DATE REVISED	DATE FILMED	DATE REVISED	DATE FILMED	FED. RD. DIST. NO.	STATE	FED. AID PROJ. NO.	SHEET NO.	TOTAL SHEETS		
				6	ARK.					
							JOB NO.	012392	24	25
							03086 - RAIL REPAIR - 65177			

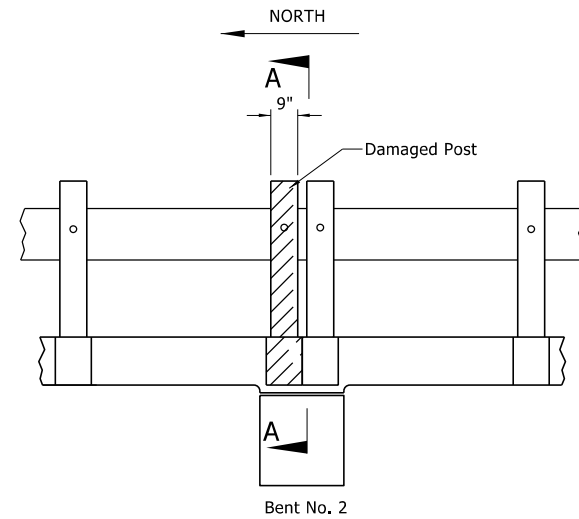

ELEVATION
Looking EAST

Note:
Any area of the existing concrete curb that is spalled is to be repaired at the direction of the Engineer using items "SURFACE PATCHING" or "SPALL REPAIR". See SP Job 012392 "CONCRETE REPAIRS".

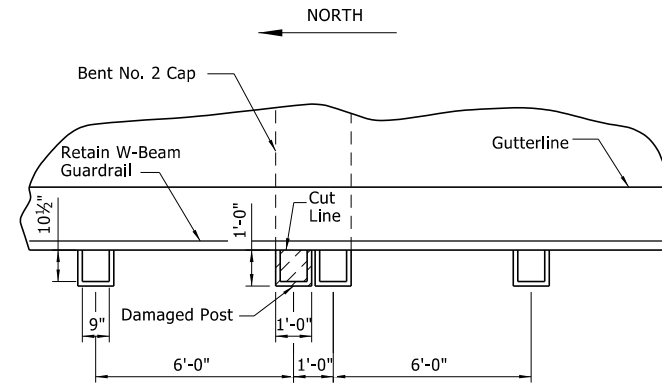

PLAN

GENERAL NOTES

CONCRETE
Concrete shall be Class "S(AE)" with a minimum 28 day compressive strength $f'c = 4,000$ psi and shall be poured in the dry.

All exposed corners shall be chamfered $\frac{3}{4}$ " unless otherwise noted.

REINFORCING STEEL
All reinforcing steel shall be Grade 60 (yield strength = 60,000 psi) conforming to AASHTO M 31 or M 322, Type A, with mill test reports.

Any additional reinforcing required by the Engineer in the field that is to be doweled into existing concrete shall be installed into drilled holes and secured using an approved non-shrink grout or resin anchoring system listed on the QPL. The diameter of the drilled holes and the installation procedures shall be as recommended by the grout manufacturer or the resin anchoring system manufacturer.

The cost of all materials, labor, equipment, and incidentals to repair the damaged portion of railing shall be included in the item "RAILING REPAIR". See SP Job 012392 "RAILING REPAIR".

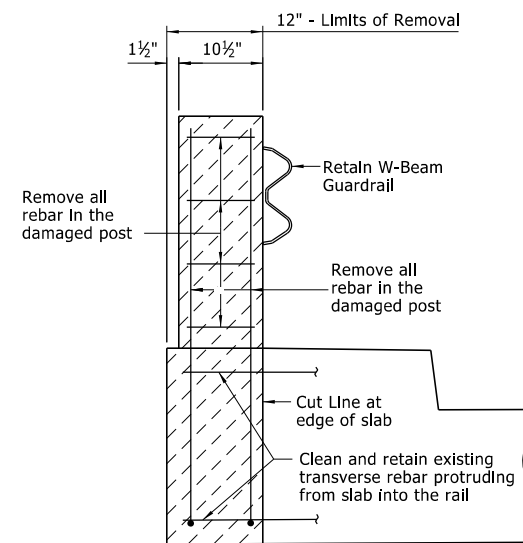

SECTION A-A
REMOVAL DETAILS

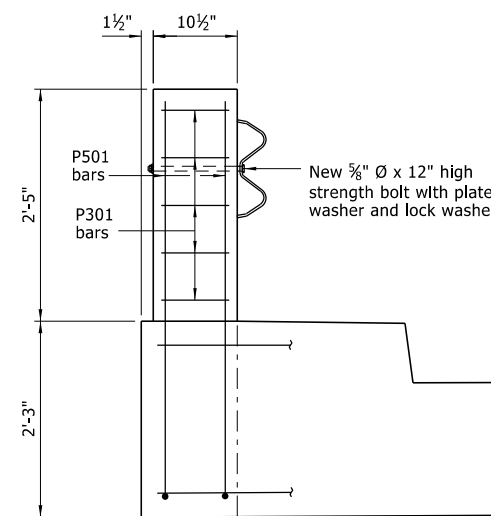

SECTION A-A
REPLACEMENT DETAILS

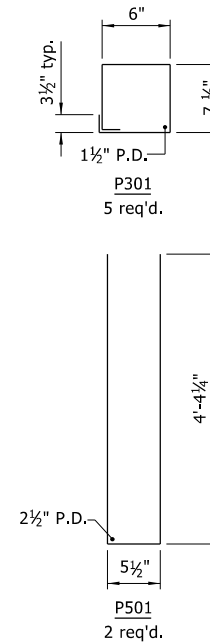

4/26/2022 12:56:02 PM
 C:\ford\work\WORKSPACE - ARDOT\187919_012392_Hydrodemolition Bridge Preservation\Design\BRIDGE - wo AG\Drawings\B012392_RAIL.dgn
 Y:\Projects\ARDOT_187919_012392_Hydrodemolition Bridge Preservation\Design\BRIDGE - wo AG\Drawings\B012392_RAIL.dgn
 REVISED DATE:



RAILING REPAIR DETAILS
ROUTE SECTION
ARKANSAS STATE HIGHWAY COMMISSION
LITTLE ROCK, ARKANSAS

BRIDGE ENGINEER
PRINT DATE: 4/26/2022

CHECKED BY: JSB
DESIGNED BY: ERBB

DATE: 03/2022
DATE: 03/2022
DATE: 03/2022

FILENAME: B012392_RAIL.dgn
SCALE: NO SCALE
DRAWING NO. 65177

DATE REVISED	DATE FILMED	DATE REVISED	DATE FILMED	FED. RD. DIST. NO.	STATE	FED. AID PROJ. NO.	SHEET NO.	TOTAL SHEETS
				6	ARK.			
				JOB NO.	012392	25	25	
① ALL BRIDGES - CONCRETE REPAIR - 65178								

CONCRETE REPAIR NOTES

- Concrete repairs shall be performed in accordance with Special Provision Job. No. 012392 "CONCRETE REPAIRS".
- Limits shown are not exact areas and locations but are representative of potential spall repair areas to be encountered. The final limits and locations shall be determined by the Engineer.
- Concrete repairs shall consist of removing all unsatisfactory concrete described as follows: any loose, delaminated, unsound, severely spalled or deteriorated concrete and replacing with an approved material listed in Special Provision Job. No. 012392 "CONCRETE REPAIRS".
- Saw cut around all damaged areas as shown on the "SAW CUT DETAIL". Exercise caution during the saw cutting operation. Any reinforcement damaged during the saw cutting will be replaced at the contractor's expense.
- Concrete repairs shall be paid for under the item "SURFACE PATCHING" when the depth of repair is 1" or less.
- Concrete repairs shall be paid for under the item "SPALL REPAIR" when the depth of the repair exceeds 1". The minimum depth of spall repair shall extend to the face of transverse reinforcing steel or to sound concrete. The exposed reinforcing steel shall be blast cleaned prior to applying the concrete mortar.
- The surface of the concrete to be repaired under the items "SURFACE PATCHING" or "SPALL REPAIR" shall be prepared in accordance with the repair mortar manufacturer's recommendations.
- Areas to be repaired under the item "SURFACE PATCHING" shall utilize "Rapid Set Mortar Mix" manufactured by CTS Cement. The contractor may submit an alternate product for review and approval.
- Areas to be repaired under the item "SPALL REPAIR" shall utilize either "Rapid Set Mortar Mix" or "Rapid Set Concrete Mix" manufactured by CTS Cement. The appropriate product shall be determined by the actual depth of repair encountered. The contractor may submit an alternate product for approval.
- After all concrete repairs are completed, the repaired concrete surfaces shall receive a Class 2 Protective Surface Treatment. The cost of the Class 2 Treatment shall be included in the item "SURFACE PATCHING" or "SPALL REPAIR".

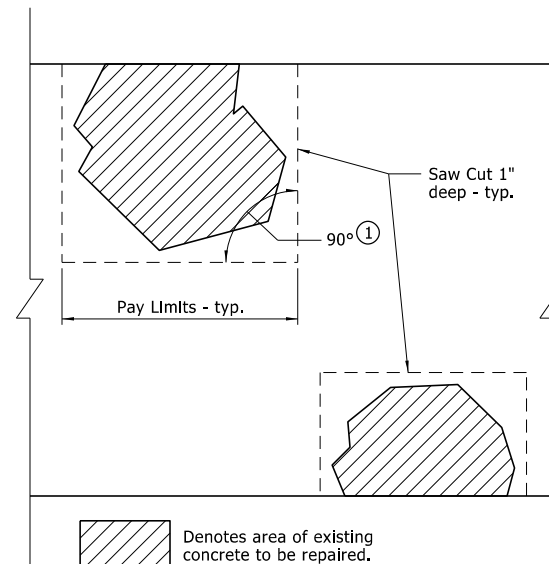

① Saw cut existing concrete 1" deep to neat lines to obtain a rectangular area.

SAW CUT DETAIL

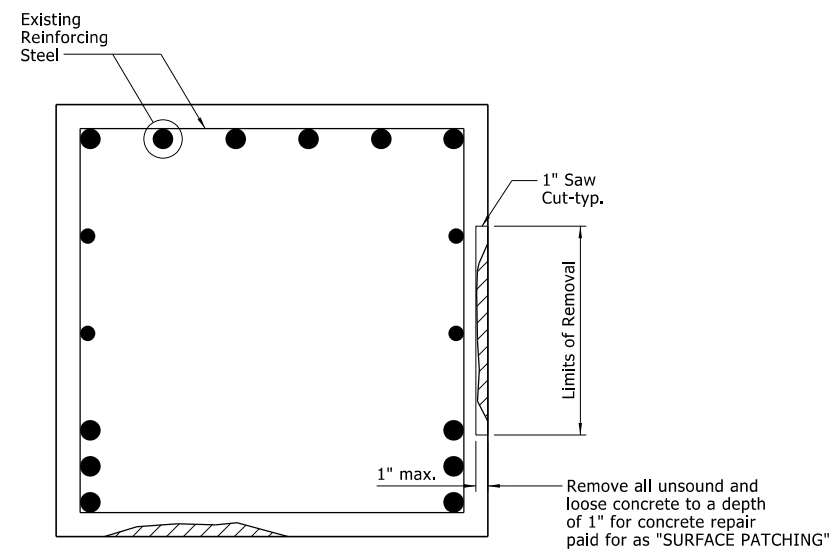

SURFACE PATCH DETAIL

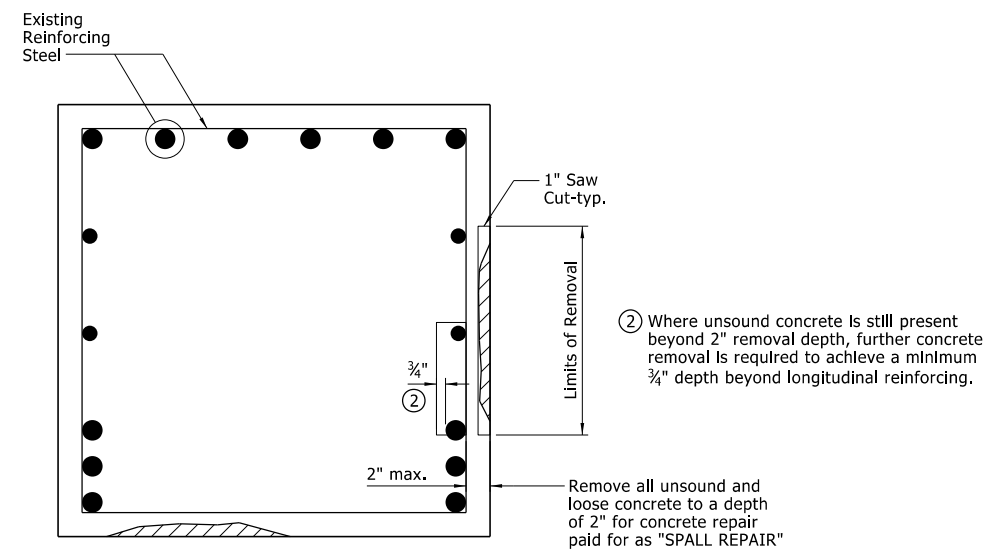

SPALL REPAIR DETAIL



CONCRETE REPAIR DETAILS
ROUTE SECTION
ARKANSAS STATE HIGHWAY COMMISSION
LITTLE ROCK, ARKANSAS

BRIDGE ENGINEER
PRINT DATE: 4/26/2022

DRAWN BY: ERBB DATE: 03/2022
CHECKED BY: MKL DATE: 03/2022
DESIGNED BY: ERBB DATE: 03/2022
BRIDGE NO. ALL BRIDGES DRAWING NO. 65178
SCALE: NONE
FILENAME: B012392_SPALL.dgn

Clifford.Wald 4/26/2022 12:56:02 PM
 WORKSPACE: ABDOT
 Y:\Projects\ABDOT_187919_012392_Hydrodemolition Bridge Preservation\Design\BRIDGE - wo AG\Drawings\B012392_SPALL.dgn
 REVISED DATE:

DATE REVISED	DATE FILMED	DATE REVISED	DATE FILMED	FED. ROAD DIST. NO.	STATE	FED. AID PROJ. NO.	SHEET NO.	TOTAL SHEETS
1/9/2020				6	ARK.			
6/25/2020								
JOB NO.								

NOTE: Details shown are typical for staged construction. When full width rehabilitation of a bridge deck is possible, adjust hydrodemolition and latex modified concrete overlay operations and details accordingly.

Stages of construction and traffic refer to Bridge Rehabilitation Work Zones as shown in Maintenance of Traffic Details. Numbering is shown for general purposes. See Roadway Plans for specific sequencing.

The minimum overlay placement length shall be a span length on simple span bridges and to an existing slab joint on continuous span bridges, unless otherwise approved by the Engineer. Refer to existing bridge drawings.

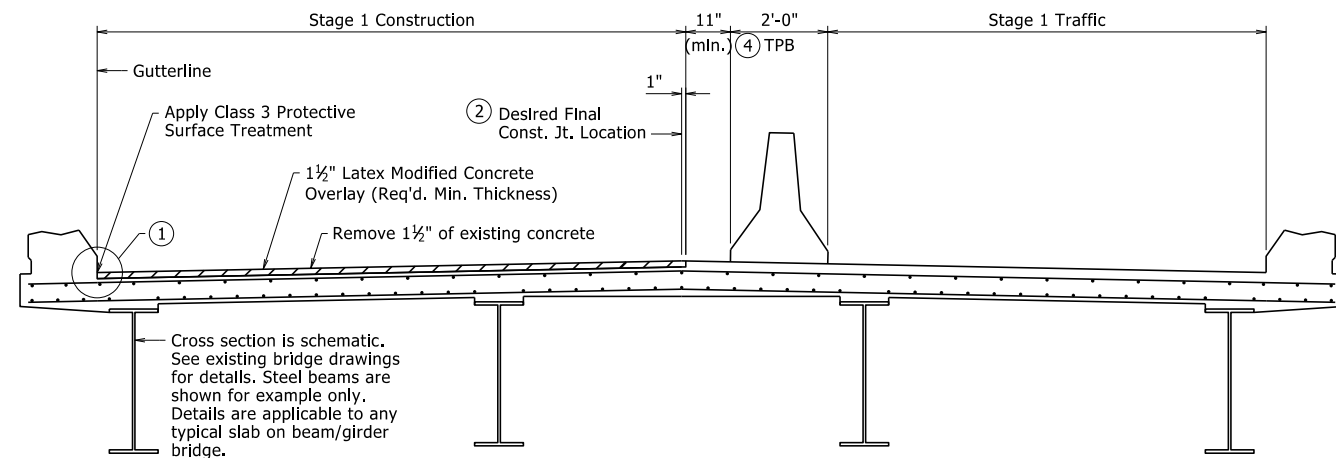

STAGE 1 LATEX MODIFIED CONCRETE OVERLAY

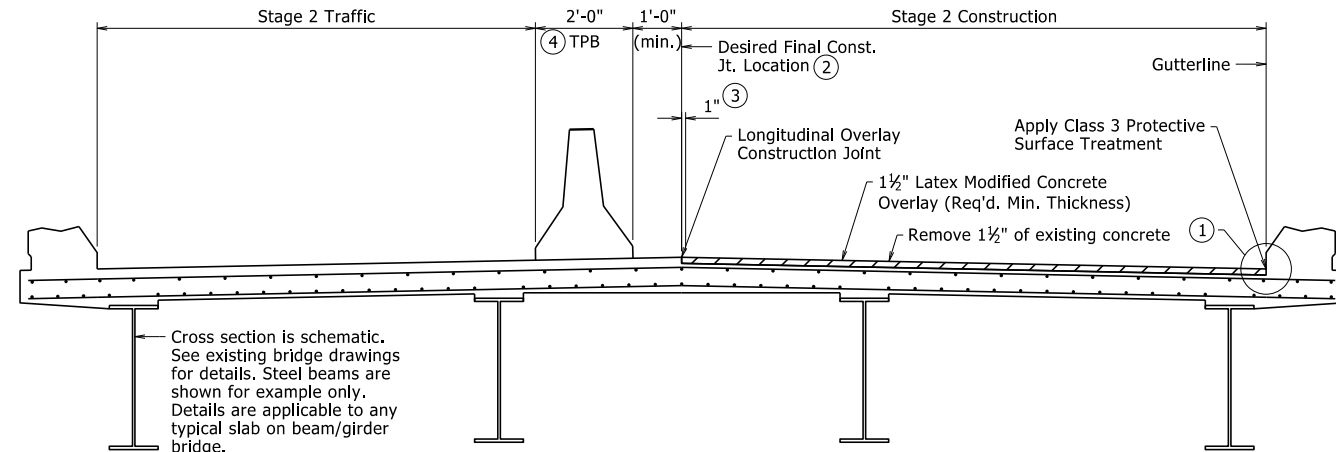

STAGE 2 LATEX MODIFIED CONCRETE OVERLAY

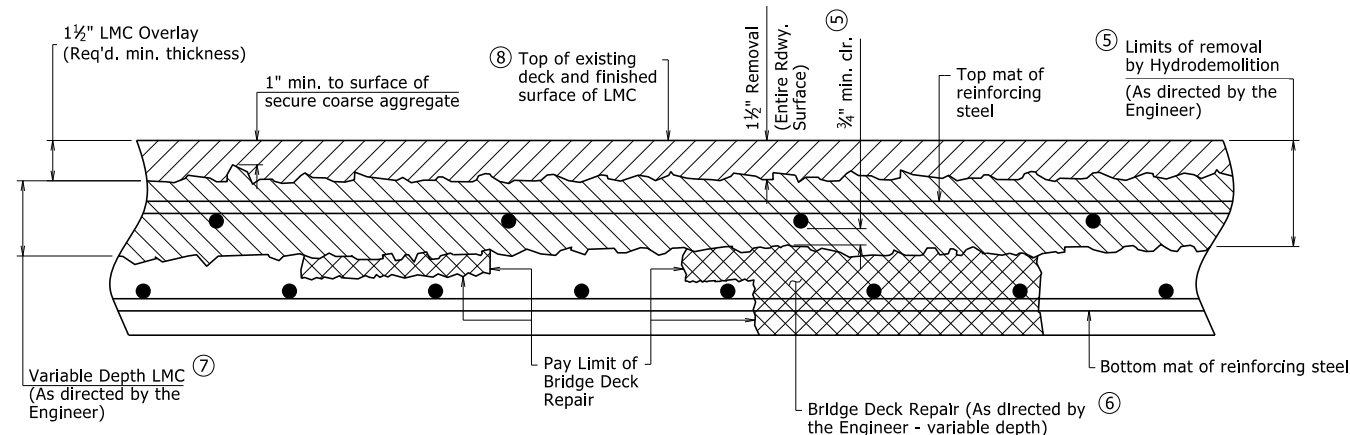

DETAILS OF HYDRODEMOLITION AND LATEX MODIFIED CONCRETE OVERLAY

- ⑤ Removal of unsound concrete beyond 1 1/2" below the original surface shall be at the direction of the Engineer. If the bond between existing concrete and the top mat of reinforcing steel is destroyed, then the concrete shall be removed to a minimum of 3/4" clearance below the bar. This removal shall be subsidiary to the Item Job SP "Hydrodemolition - Class _".
- ⑥ Areas requiring additional repair, as determined by the Engineer, shall be repaired in accordance with the Job SP "Bridge Deck Repair for Latex Modified Concrete Overlays".

- ⑦ Depth varies to achieve minimum clearance below top mat of reinforcing steel, where required.
- ⑧ Finished surface of LMC Overlay shall match existing concrete deck surfaces unless Increase Is required to maintain minimum required LMC Overlay thickness and a minimum of 1 1/2" cover to reinforcing steel and shear connectors.

- ① Hand tools shall be used as required to remove concrete adjacent to curbs, rails, and armored expansion joints.
- ② For staged construction, the final construction joint location shall be established by the Engineer to satisfy MOT and construction requirements. The desired location is at the C.L. Bridge, C.L. Lane, or Edge of Lane, but in no case shall be positioned in the line of a wheel path.
- ③ For staged construction, saw cut and remove 1" of initial Latex Modified Concrete Overlay when preparing surface for adjacent overlay.
- ④ For staged construction, Temporary Precast Barrier (TPB) shall not be connected to the surface of the bridge deck. See Std. Dwg. TC-4 for additional details. Plastic drums shall be used in lieu of concrete barriers where shown in the Roadway Plans, see Std. Dwg. TC-3 for additional details.

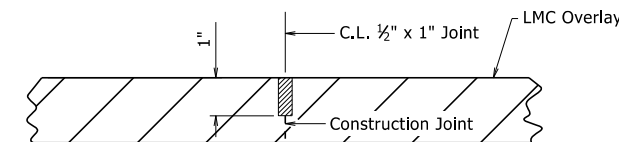

LONGITUDINAL OVERLAY CONSTRUCTION JOINT DETAIL

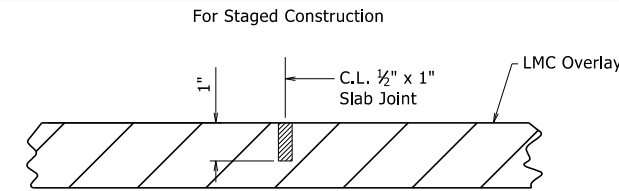

TRANSVERSE OVERLAY JOINT DETAIL

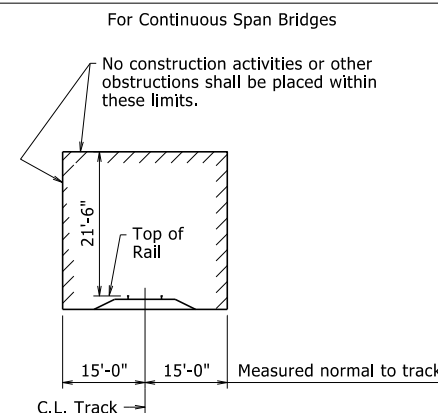

MINIMUM CONSTRUCTION CLEARANCE ENVELOPE

See Job SP "Insurance, Construction, and Flagging Requirements on Railroad Property" for additional railroad construction requirements.

- ⚠ Modified Hydrodemolition SP reference to include "- Class _". By: KKY, Checked by: SWP; 1/9/2020.
- ⚠ Modified Joint Rehabilitation to include unarmored joints. By: KKY, Checked by: SWP; 6/25/2020.

This document was originally issued and sealed by Charles R. Ellis, PE No. 9235, on November 7, 2019. This copy is not a signed and sealed document.

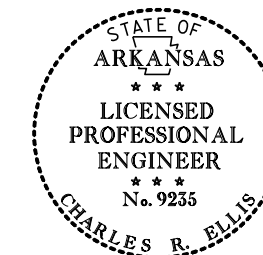

GENERAL NOTES: ① HYDRO/LMC OVERLAY - 55060

CONSTRUCTION SPECIFICATIONS: Arkansas State Highway and Transportation Department Standard Specifications for Highway Construction (2014 edition) with applicable Supplemental Specifications and Special Provisions. Section and Subsection refer to the Standard Specifications unless otherwise noted in the Plans.

Details shown are schematic. The Contractor shall make check measurements in the field and make any adjustments necessary to meet the required clearances and fit the new work to the existing structure(s).

The operation or placement of vehicles, equipment, and/or materials on the subject bridge(s) necessary for the completion of this work shall be evaluated in accordance with Subsection 105.14. Certifications of the adequacy of all components for the anticipated loads shall address the capacity of the existing structure at all phases of this work.

Where applicable, construction activities for the existing bridge(s) over roadways and railroads shall be in accordance with the Job SP "Special Safety Requirements for Bridges" and as shown in "Minimum Construction Clearance Envelope".

⚠ HYDRODEMOLITION: The entire roadway surface of the existing bridge deck and approach slabs and gutters, as applicable, shall receive hydrodemolition in accordance with the Job SP "Hydrodemolition - Class _" to a planned depth of 1 1/2" below the existing bridge deck surface. Deteriorated concrete in the bridge deck below this depth shall be removed at the direction of the Engineer and up to the limits detailed. These areas shall be measured by the square yard and shall be paid for at the unit price bid for the Item Job SP "Hydrodemolition - Class _". Prior to hydrodemolition, cold milling of the concrete deck to a maximum depth of 1" will be allowed unless there will be a conflict with the existing reinforcing steel.

BRIDGE DECK REPAIR: After hydrodemolition, the deck surface shall be sounded and any areas of unsound, delaminated, or otherwise deteriorated concrete shall be removed at the direction of the Engineer and in accordance with Job SP "Bridge Deck Repair for Latex Modified Concrete Overlays".

LATEX MODIFIED CONCRETE OVERLAY: The entire area of the hydrodemolition shall receive a Latex Modified Concrete (LMC) Overlay to a planned depth of 1 1/2" below the existing bridge deck surface in accordance with Job SP "Latex Modified Concrete Overlay". These areas shall be measured by the square yard and shall be paid for at the unit price bid for the Item Job SP "Latex Modified Concrete Overlay (1 1/2" Thick)". Areas of the existing bridge deck removed at the direction of the Engineer to a depth greater than 1 1/2" below the existing bridge deck surface shall be filled with LMC concurrent to the placement of the 1 1/2" LMC Overlay. This area shall be measured and paid for in accordance with Job SP "Latex Modified Concrete Overlay".

GROOVED FINISH: The LMC Overlay surface of the bridge deck and approach slabs and gutters, as applicable, shall be given a grooved finish as specified for final finishing in Subsection 802.19 for Class 7 Grooved Bridge Roadway Surface Finish and in accordance with Job SP "Latex Modified Concrete Overlay".

PROTECTIVE SURFACE TREATMENT: The longitudinal joint between the LMC Overlay and the adjacent existing concrete curb or rail shall be given a Class 3 Protective Surface Treatment as specified in Section 803 and in accordance with Job SP "Latex Modified Concrete Overlay". The roadway surface of the completed LMC Overlay shall be given a Class 1 Protective Surface Treatment as specified in Section 803.

⚠ JOINT REHABILITATION: After the placement of the LMC Overlay and if shown in the plans, the existing armored joints shall be given a poured silicone joint sealant as specified in Section 809 and as shown in "Poured Silicone Joint Seal Details" on Standard Drawing No. 55064, and the existing unarmored joints shall be given a Type A Joint Rehabilitation as specified in Section 509 and Job SP "Joint Rehabilitation for Bridge Decks". Backwall repair, if shown in the plans or as directed by the Engineer, shall be completed prior to installation of the joint sealant.

If shown in the plans, the existing neoprene strip seal shall be removed and replaced. See "Strip Seal Joint Details" on Standard Drawing No. 55064.

NOTE: When "Very Early Strength Latex Modified Concrete Overlay (1 1/2" Thick)" is shown in the plans for a particular bridge, all reference to "Latex Modified Concrete Overlay" and "LMC" on this sheet shall be considered synonymous with "Very Early Strength Latex Modified Concrete Overlay" and "VESLMC" for that bridge. See Job SP "Very Early Strength Latex Modified Concrete Overlay" for additional information.

STANDARD DETAILS FOR HYDRODEMOLITION AND LMC OVERLAY SLAB ON BEAM/GIRDER BRIDGES

ARKANSAS STATE HIGHWAY COMMISSION

LITTLE ROCK, ARK.

DRAWN BY: KKY DATE: 11/7/2019 FILENAME: b55060.dgn
 CHECKED BY: SWP DATE: 11/7/2019 SCALE: None
 DESIGNED BY: STD. DATE: -----

BRIDGE ENGINEER

DRAWING NO. 55060

PRINT DATE: 3/22/2021

DATE REVISION	DATE FILMED	DATE REVISION	DATE FILMED	FED. ROAD DIST. NO.	STATE	FED. AID PROJ. NO.	SHEET NO.	TOTAL SHEETS
1/9/2020				6	ARK.			
6/25/2020								
				JOB NO.	HYDRO/LMC OVERLAY - 55061			

Stages of construction and traffic refer to Bridge Rehabilitation Work Zones as shown in Maintenance of Traffic Details. Numbering is shown for general purposes. See Roadway Plans for specific sequencing.

The minimum overlay placement length shall be a span length on simple span bridges and to an existing slab joint on continuous span bridges, unless otherwise approved by the Engineer. Refer to existing bridge drawings.

NOTE: Details shown are typical for staged construction. When full width rehabilitation of a bridge deck is possible, adjust hydrodemolition and latex modified concrete overlay operations and details accordingly.

- Hand tools shall be used as required to remove concrete adjacent to curbs, rails, and armored expansion joints.
- For staged construction, the final construction joint location shall be established by the Engineer to satisfy MOT and construction requirements. The desired location is at the C.L. Bridge, C.L. Lane, or Edge of Lane, but in no case shall be positioned in the line of a wheel path.
- For staged construction, saw cut and remove 1" of Initial Latex Modified Concrete Overlay when preparing surface for adjacent overlay.
- For staged construction, Temporary Precast Barrier (TPB) shall not be connected to the surface of the bridge deck. See Std. Dwg. TC-4 for additional details. Plastic drums shall be used in lieu of concrete barriers where shown in the Roadway Plans, see Std. Dwg. TC-3 for additional details.

GENERAL NOTES: **1** CONSTRUCTION SPECIFICATIONS: Arkansas State Highway and Transportation Department Standard Specifications for Highway Construction (2014 edition) with applicable Supplemental Specifications and Special Provisions. Section and Subsection refer to the Standard Specifications unless otherwise noted in the Plans.

Details shown are schematic. The Contractor shall make check measurements in the field and make any adjustments necessary to meet the required clearances and fit the new work to the existing structure(s).

The operation or placement of vehicles, equipment, and/or materials on the subject bridge(s) necessary for the completion of this work shall be evaluated in accordance with Subsection 105.14. Certifications of the adequacy of all components for the anticipated loads shall address the capacity of the existing structure at all phases of this work.

Where applicable, construction activities for the existing bridge(s) over roadways and railroads shall be in accordance with the Job SP "Special Safety Requirements for Bridges" and as shown in "Minimum Construction Clearance Envelope".

HYDRODEMOLITION: The entire roadway surface of the existing bridge deck and approach slabs and gutters, as applicable, shall receive hydrodemolition in accordance with the Job SP "Hydrodemolition - Class _" to a planned depth of 1/2" below the existing bridge deck surface. Deteriorated concrete in the bridge deck below this depth shall be removed at the direction of the Engineer and up to the limits detailed. These areas shall be measured by the square yard and shall be paid for at the unit price bid for the item Job SP "Hydrodemolition - Class _".

BRIDGE DECK REPAIR: After hydrodemolition, the deck surface shall be sounded and any areas of unsound, delaminated, or otherwise deteriorated concrete shall be removed at the direction of the Engineer and in accordance with Job SP "Bridge Deck Repair for Latex Modified Concrete Overlays".

LATEX MODIFIED CONCRETE OVERLAY: The entire area of the hydrodemolition shall receive a Latex Modified Concrete (LMC) Overlay with a minimum thickness of 1 1/2" in accordance with Job SP "Latex Modified Concrete Overlay". These areas shall be measured by the square yard and shall be paid for at the unit price bid for the item Job SP "Latex Modified Concrete Overlay (1 1/2" Thick)". Areas of the existing bridge deck removed at the direction of the Engineer to a depth greater than 1/2" below the existing bridge deck surface shall be filled with LMC concurrent to the placement of the 1 1/2" LMC Overlay. This area shall be measured and paid for in accordance with Job SP "Latex Modified Concrete Overlay".

GROOVED FINISH: The LMC Overlay surface of the bridge deck and approach slabs and gutters, as applicable, shall be given a grooved finish as specified for final finishing in Subsection 802.19 for Class 7 Grooved Bridge Roadway Surface Finish and in accordance with Job SP "Latex Modified Concrete Overlay".

PROTECTIVE SURFACE TREATMENT: The longitudinal joint between the LMC Overlay and the adjacent existing concrete curb or rail shall be given a Class 3 Protective Surface Treatment as specified in Section 803 and in accordance with Job SP "Latex Modified Concrete Overlay". The roadway surface of the completed LMC Overlay shall be given a Class 1 Protective Surface Treatment as specified in Section 803.

JOINT REHABILITATION: After the placement of the LMC Overlay and if shown in the plans, the existing armored joints shall be given a poured silicone joint sealant as specified in Section 809 and as shown in "Poured Silicone Joint Seal Details" on Standard Drawing No. 55064, and the existing unarmored joints shall be given a Type A Joint Rehabilitation as specified in Section 509 and Job SP "Joint Rehabilitation for Bridge Decks". Backwall repair, if shown in the plans or as directed by the Engineer, shall be completed prior to installation of the joint sealant.

If shown in the plans, the existing neoprene strip seal shall be removed and replaced. See "Strip Seal Joint Details" on Standard Drawing No. 55064.

NOTE: When "Very Early Strength Latex Modified Concrete Overlay (1 1/2" Thick)" is shown in the plans for a particular bridge, all reference to "Latex Modified Concrete Overlay" and "LMC" on this sheet shall be considered synonymous with "Very Early Strength Latex Modified Concrete Overlay" and "VESLMC" for that bridge. See Job SP "Very Early Strength Latex Modified Concrete Overlay" for additional information.

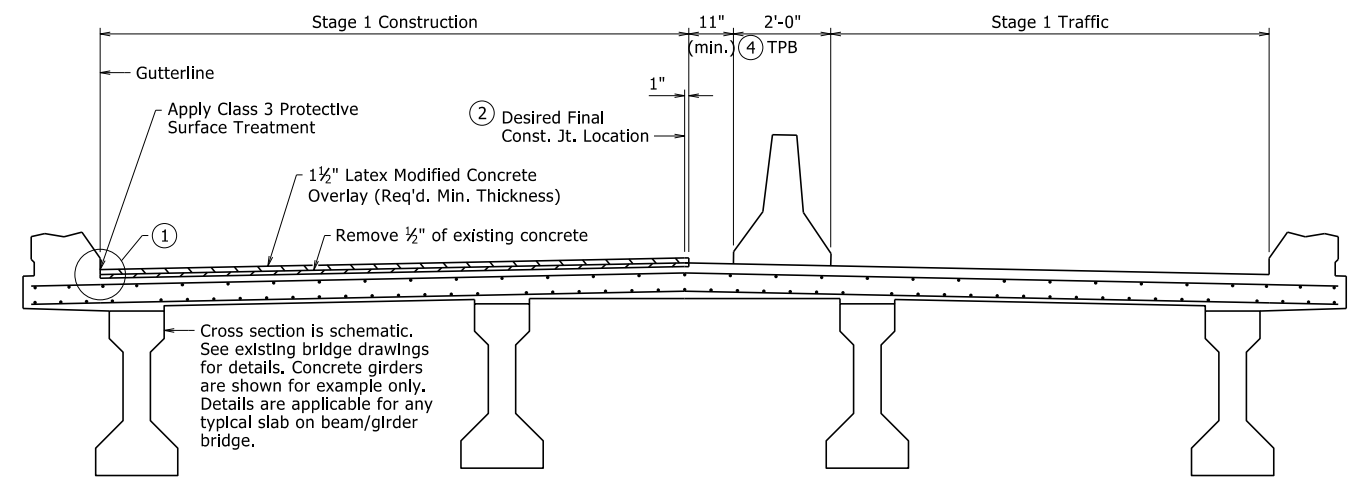

STAGE 1 LATEX MODIFIED CONCRETE OVERLAY

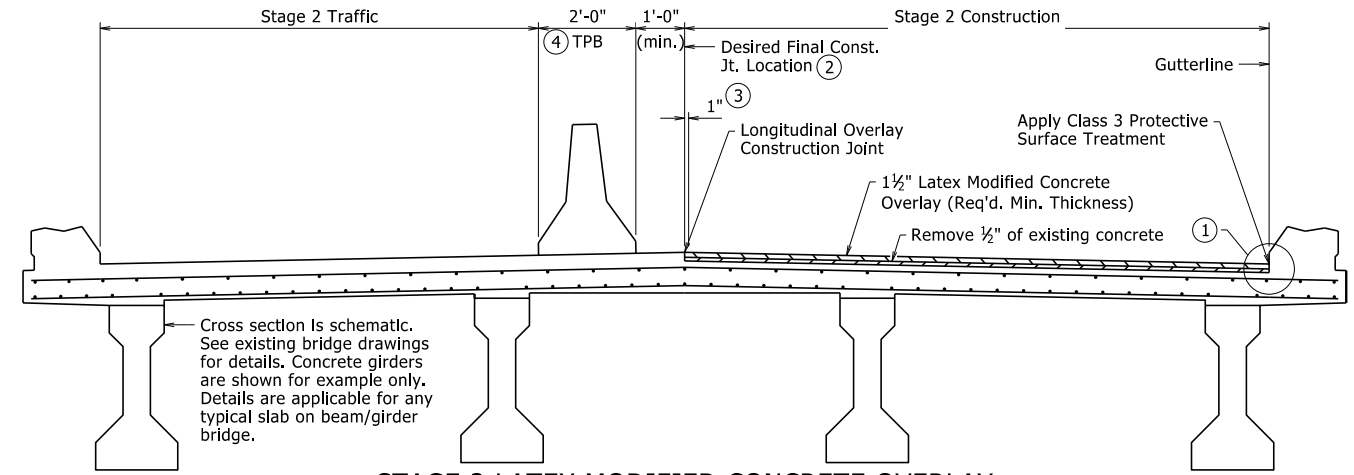

STAGE 2 LATEX MODIFIED CONCRETE OVERLAY

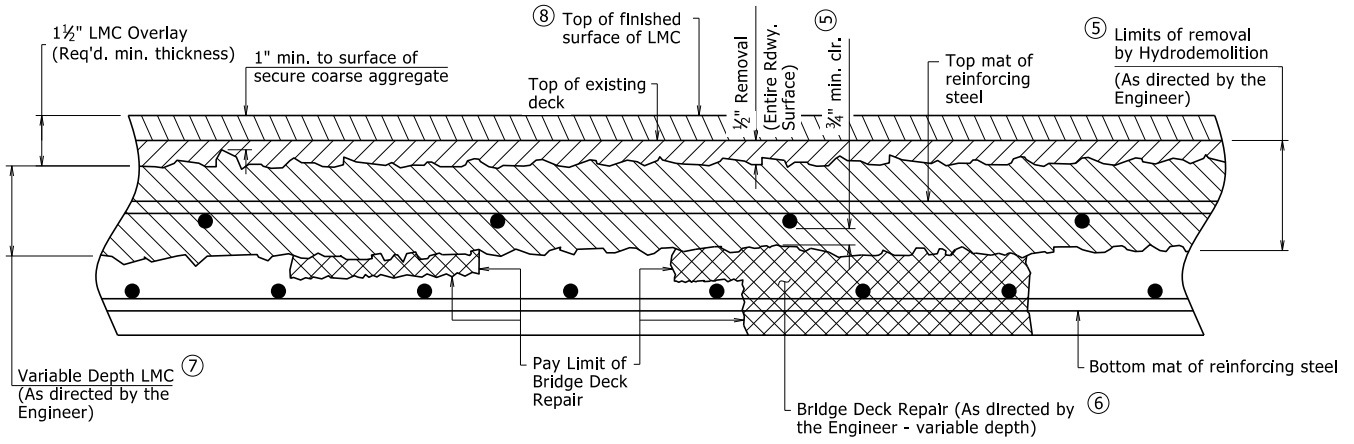

DETAILS OF HYDRODEMOLITION AND LATEX MODIFIED CONCRETE OVERLAY

- Removal of unsound concrete beyond 1/2" below the original surface shall be at the direction of the Engineer. If the bond between existing concrete and the top mat of reinforcing steel is destroyed, then the concrete shall be removed to a minimum of 3/4" clearance below the bar. This removal shall be subsidiary to the item Job SP "Hydrodemolition - Class _".
- Depth varies to achieve minimum clearance below top mat of reinforcing steel, where required.
- Finished surface of LMC Overlay shall be increased as required to maintain minimum required LMC Overlay thickness and a minimum of 1 1/2" cover to reinforcing steel and shear connectors.
- Areas requiring additional repair, as determined by the Engineer, shall be repaired in accordance with the Job SP "Bridge Deck Repair for Latex Modified Concrete Overlays".

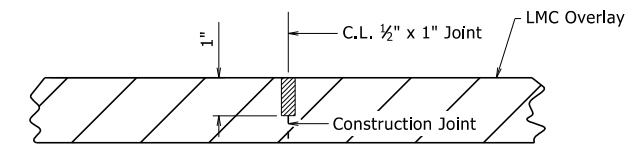

Use 1/2" x 1" Type 3 or 4 Joint Sealer. See Subsections 501.02(h) and 501.05(j). Backer Rod will not be required. Joint Sealer shall be measured and paid for as LMC Overlay. Longitudinal construction joints shall be sawed as soon as the concrete has sufficiently set to allow sawing of the joint without damage to the overlay. Seal color shall be gray or other color similar to concrete.

LONGITUDINAL OVERLAY CONSTRUCTION JOINT DETAIL

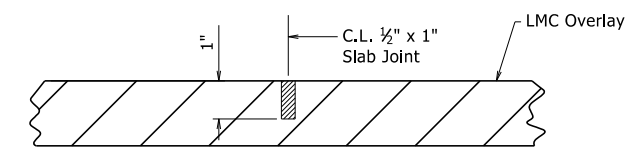

Use 1/2" x 1" Type 3 or 4 Joint Sealer. See Subsections 501.02(h) and 501.05(j). Backer Rod will not be required. Joint Sealer shall be measured and paid for as LMC Overlay. Slab joints shall extend from gutterline to gutterline. Slab joints shall be sawed as soon as the concrete has sufficiently set to allow sawing of the joint without damage to the overlay. Slab joints shall be placed at all pouring sequence construction joints and are required at existing slab joint locations. Pouring sequence construction joints shall align between stages of construction. The joint sealer shall extend across the deck from gutterline to gutterline. Seal color shall be gray or other color similar to concrete.

TRANSVERSE OVERLAY JOINT DETAIL

For Continuous Span Bridges

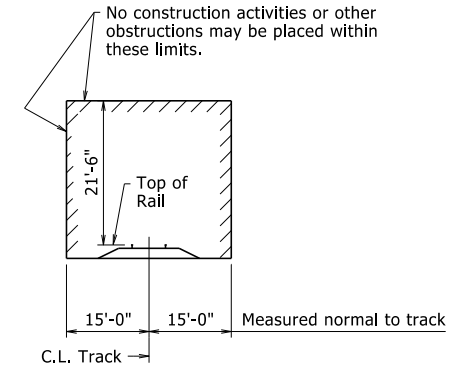

MINIMUM CONSTRUCTION CLEARANCE ENVELOPE

See Job SP "Insurance, Construction, and Flagging Requirements on Railroad Property" for additional railroad construction requirements.

- Modified Hydrodemolition SP reference to include "- Class _". By: KKY, Checked by: SWP; 1/9/2020.
- Modified Joint Rehabilitation to include unarmored joints. By: KKY, Checked by: SWP; 6/25/2020.

This document was originally issued and sealed by Charles R. Ellis, PE No. 9235, on November 7, 2019. This copy is not a signed and sealed document.

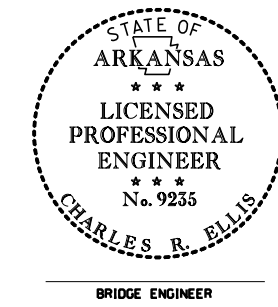

STANDARD DETAILS FOR HYDRODEMOLITION AND LMC OVERLAY SLAB ON BEAM/GIRDER BRIDGES WITH GRADE RAISE
ARKANSAS STATE HIGHWAY COMMISSION
 LITTLE ROCK, ARK.

DRAWN BY: KKY DATE: 11/7/2019 FILENAME: b55061.dgn
 CHECKED BY: SWP DATE: 11/7/2019 SCALE: None
 DESIGNED BY: STD. DATE: -----

DRAWING NO. 55061

PRINT DATE: 11/4/2020

DATE REVISED	DATE FILMED	DATE REVISED	DATE FILMED	FED. ROAD DIST. NO.	STATE	FED. AID PROJ. NO.	SHEET NO.	TOTAL SHEETS
1/9/2020				6	ARK.			
6/25/2020								
				JOB NO.		HYDRO/LMC OVERLAY - 55062		

NOTE: Details shown are typical for staged construction. When full width rehabilitation of a bridge deck is possible, adjust hydrodemolition and latex modified concrete overlay operations and details accordingly.

Stages of Construction refer to Bridge Rehabilitation Work Zones as shown in Maintenance of Traffic Details. Numbering is shown for general purposes. See Roadway Plans for specific sequencing.

The minimum overlay placement length shall be a span length on simple span bridges and to a slab joint on continuous span, unless otherwise approved by the Engineer. Refer to existing bridge drawings.

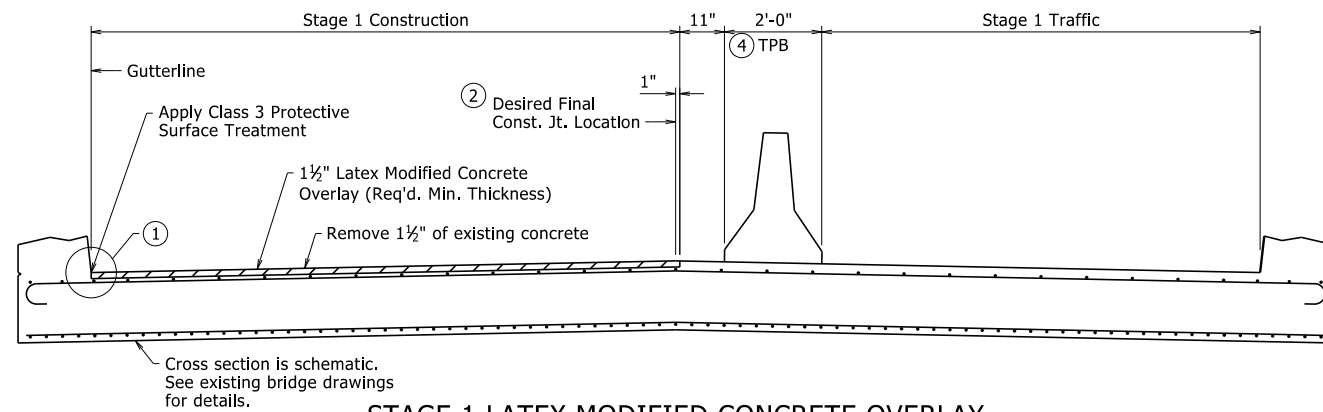

STAGE 1 LATEX MODIFIED CONCRETE OVERLAY

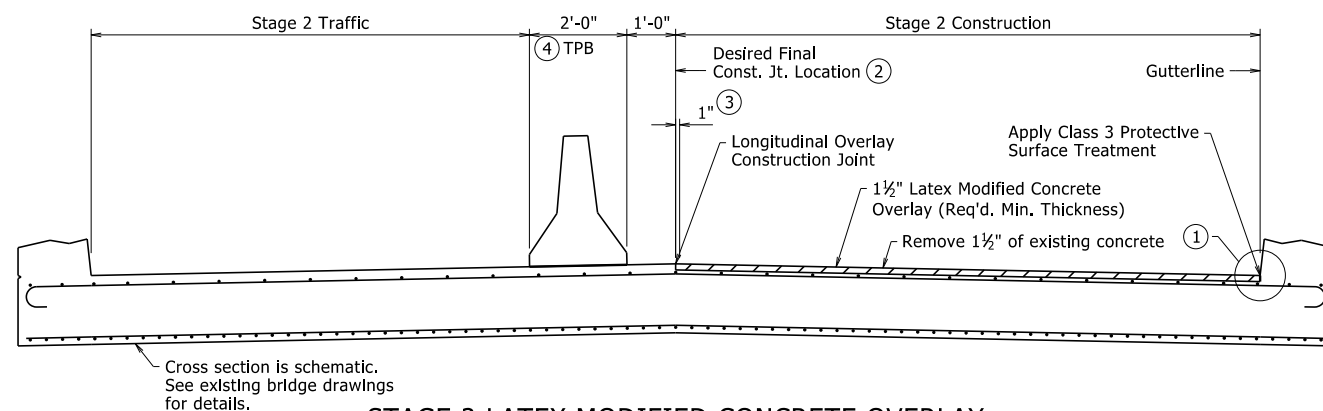

STAGE 2 LATEX MODIFIED CONCRETE OVERLAY

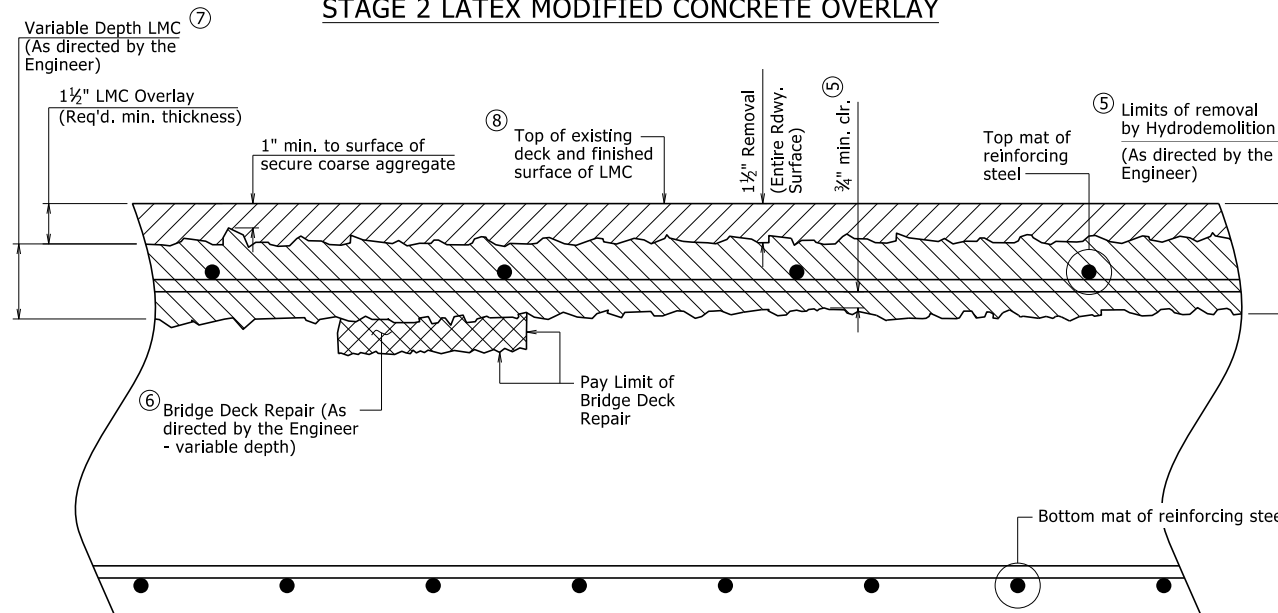

DETAILS OF HYDRODEMOLITION AND LATEX MODIFIED CONCRETE OVERLAY

- ⑤ Removal of unsound concrete beyond 1 1/2" below the original surface shall be at the direction of the Engineer. If the bond between existing concrete and the top mat of reinforcing steel is destroyed, then the concrete shall be removed to a minimum of 3/4" clearance below the bar. This removal shall be subsidiary to the Item Job SP "Hydrodemolition - Class _".
- ⑥ Areas requiring additional repair, as determined by the Engineer, shall be repaired in accordance with the Job SP "Bridge Deck Repair for Latex Modified Concrete Overlays".
- ⑦ Depth varies to achieve minimum clearance below top mat of reinforcing steel, where required.
- ⑧ Finished surface of LMC Overlay shall match existing concrete deck surfaces unless increase is required to maintain minimum required LMC Overlay thickness and a minimum of 1 1/2" cover to reinforcing steel.

- ① Hand tools shall be used as required to remove concrete adjacent to curbs, rails, and armored expansion joints.
- ② For staged construction, the final construction joint location shall be established by the Engineer to satisfy MOT and construction requirements. The desired location is at the C.L. Bridge, C.L. Lane, or Edge of Lane, but in no case shall be positioned in the line of a wheel path.
- ③ For staged construction, saw cut and remove 1" of initial Latex Modified Concrete Overlay when preparing surface for adjacent overlay.
- ④ For staged construction, Temporary Precast Barrier (TPB) shall not be connected to the surface of the bridge deck. See Std. Dwg. TC-4 for additional details. Plastic drums shall be used in lieu of concrete barriers where shown in the Roadway Plans, see Std. Dwg. TC-3 for additional details.

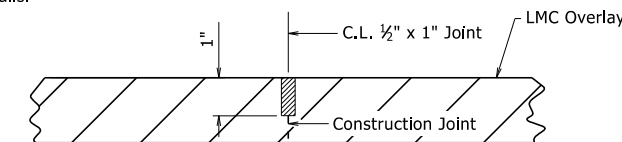

Use 1/2" x 1" Type 3 or 4 Joint Sealer. See Subsections 501.02(h) and 501.05(j). Backer Rod will not be required. Joint Sealer shall be measured and paid for as LMC Overlay. Longitudinal construction joints shall be sawed as soon as the concrete has sufficiently set to allow sawing of the joint without damage to the overlay. Seal color shall be gray or other color similar to concrete.

LONGITUDINAL OVERLAY CONSTRUCTION JOINT DETAIL

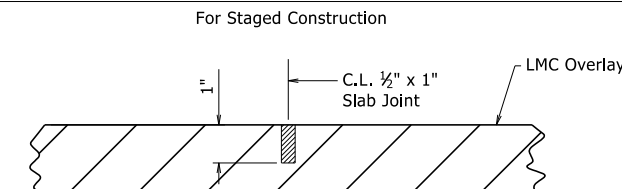

Use 1/2" x 1" Type 3 or 4 Joint Sealer. See Subsections 501.02(h) and 501.05(j). Backer Rod will not be required. Joint Sealer shall be measured and paid for as LMC Overlay. Slab joints shall extend from gutterline to gutterline. Slab joints shall be sawed as soon as the concrete has sufficiently set to allow sawing of the joint without damage to the overlay. Slab joints shall be placed at all pouring sequence construction joints and are required at existing slab joint locations. Pouring sequence construction joints shall align between stages of construction. The joint sealer shall extend across the deck from gutterline to gutterline. Seal color shall be gray or other color similar to concrete.

TRANSVERSE OVERLAY JOINT DETAIL

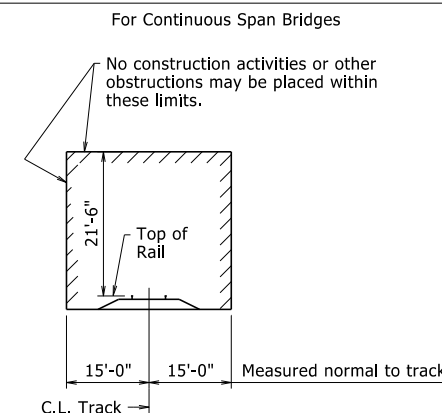

MINIMUM CONSTRUCTION CLEARANCE ENVELOPE

See Job SP "Insurance, Construction, and Flagging Requirements on Railroad Property" for additional railroad construction requirements.

- ⚠ Modified Hydrodemolition SP reference to include "- Class _". By: KWY, Checked by: SWP; 1/9/2020.
- ⚠ Modified Joint Rehabilitation for additional clarification of unarmored joint work. By: KWY, Checked by: SWP; 6/25/2020.

This document was originally issued and sealed by Charles R. Ellis, PE No. 9235, on November 7, 2019. This copy is not a signed and sealed document.

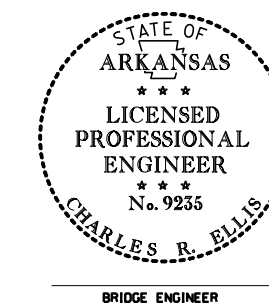

GENERAL NOTES:

CONSTRUCTION SPECIFICATIONS: Arkansas State Highway and Transportation Department Standard Specifications for Highway Construction (2014 edition) with applicable Supplemental Specifications and Special Provisions. Section and Subsection refer to the Standard Specifications unless otherwise noted in the Plans.

Details shown are schematic. The Contractor shall make check measurements in the field and make any adjustments necessary to meet the required clearances and fit the new work to the existing structure(s).

The operation or placement of vehicles, equipment, and/or materials on the subject bridge(s) necessary for the completion of this work shall be evaluated in accordance with Subsection 105.14. Certifications of the adequacy of all components for the anticipated loads shall address the capacity of the existing structure at all phases of this work.

Where applicable, construction activities for the existing bridge(s) over roadways and railroads shall be in accordance with the Job SP "Special Safety Requirements for Bridges" and as shown in "Minimum Construction Clearance Envelope".

⚠ HYDRODEMOLITION: The entire roadway surface of the existing bridge deck and approach slabs and gutters, as applicable, shall receive hydrodemolition in accordance with the Job SP "Hydrodemolition - Class _" to a planned depth of 1 1/2" below the existing bridge deck surface. Deteriorated concrete in the bridge deck below this depth shall be removed at the direction of the Engineer and up to the limits detailed. These areas shall be measured by the square yard and shall be paid for at the unit price bid for the Item Job SP "Hydrodemolition - Class _". Prior to hydrodemolition, cold milling of the concrete deck to a maximum depth of 1" will be allowed unless there will be a conflict with the existing reinforcing steel.

BRIDGE DECK REPAIR: After hydrodemolition, the deck surface shall be sounded and any areas of unsound, delaminated, or otherwise deteriorated concrete shall be removed at the direction of the Engineer and in accordance with Job SP "Bridge Deck Repair for Latex Modified Concrete Overlays".

LATEX MODIFIED CONCRETE OVERLAY: The entire area of the hydrodemolition shall receive a Latex Modified Concrete (LMC) Overlay to a planned depth of 1 1/2" below the existing bridge deck surface in accordance with Job SP "Latex Modified Concrete Overlay". These areas shall be measured by the square yard and shall be paid for at the unit price bid for the Item Job SP "Latex Modified Concrete Overlay (1 1/2" Thick)". Areas of the existing bridge deck removed at the direction of the Engineer to a depth greater than 1 1/2" below the existing bridge deck surface shall be filled with LMC concurrent to the placement of the 1 1/2" LMC Overlay. This area shall be measured and paid for in accordance with Job SP "Latex Modified Concrete Overlay".

GROOVED FINISH: The LMC Overlay surface of the bridge deck and approach slabs and gutters, as applicable, shall be given a grooved finish as specified for final finishing in Subsection 802.19 for Class 7 Grooved Bridge Roadway Surface Finish and in accordance with Job SP "Latex Modified Concrete Overlay".

PROTECTIVE SURFACE TREATMENT: The longitudinal joint between the LMC Overlay and the adjacent existing concrete curb or rail shall be given a Class 3 Protective Surface Treatment as specified in Section 803 and in accordance with Job SP "Latex Modified Concrete Overlay". The roadway surface of the completed LMC Overlay shall be given a Class 1 Protective Surface Treatment as specified in Section 803.

⚠ JOINT REHABILITATION: After the placement of the LMC Overlay and if shown in the plans, the existing armored joints shall be given a poured silicone joint sealant as specified in Section 809 and as shown in "Poured Silicone Joint Seal Details" on Standard Drawing No. 55064, and the existing unarmored joints shall be given a Type A Joint Rehabilitation as specified in Section 509 and Job SP "Joint Rehabilitation for Bridge Decks". Backwall repair, if shown in the plans or as directed by the Engineer, shall be completed prior to installation of the joint sealant.

NOTE: When "Very Early Strength Latex Modified Concrete Overlay (1 1/2" Thick)" is shown in the plans for a particular bridge, all reference to "Latex Modified Concrete Overlay" and "LMC" on this sheet shall be considered synonymous with "Very Early Strength Latex Modified Concrete Overlay" and "VESLMC" for that bridge. See Job SP "Very Early Strength Latex Modified Concrete Overlay" for additional information.

STANDARD DETAILS FOR
HYDRODEMOLITION AND LMC OVERLAY
REINFORCED CONCRETE SLAB STRUCTURES
ARKANSAS STATE HIGHWAY COMMISSION
LITTLE ROCK, ARK.

DRAWN BY: KWY DATE: 11/7/2019 FILENAME: b55062.dgn
CHECKED BY: SWP DATE: 11/7/2019 SCALE: None
DESIGNED BY: STD. DATE:

DRAWING NO. 55062

DATE REVISION	DATE FILMED	DATE REVISION	DATE FILMED	FED. ROAD DIST. NO.	STATE	FED. AID PROJ. NO.	SHEET NO.	TOTAL SHEETS
1/9/2020				6	ARK.			
6/25/2020								
				JOB NO.		HYDRO/LMC OVERLAY - 55063		

Stages of Construction refer to Bridge Rehabilitation Work Zones as shown in Maintenance of Traffic Details. Numbering is shown for general purposes. See Roadway Plans for specific sequencing.

The minimum overlay placement length shall be a span length. Refer to existing bridge drawings.

NOTE: Details shown are typical for staged construction. When full width rehabilitation of a bridge deck is possible, adjust hydrodemolition and latex modified concrete overlay operations and details accordingly.

GENERAL NOTES: **1** CONSTRUCTION SPECIFICATIONS: Arkansas State Highway and Transportation Department Standard Specifications for Highway Construction (2014 edition) with applicable Supplemental Specifications and Special Provisions. Section and Subsection refer to the Standard Specifications unless otherwise noted in the Plans.

Details shown are schematic. The Contractor shall make check measurements in the field and make any adjustments necessary to meet the required clearances and fit the new work to the existing structure(s).

The operation or placement of vehicles, equipment, and/or materials on the subject bridge(s) necessary for the completion of this work shall be evaluated in accordance with Subsection 105.14. Certifications of the adequacy of all components for the anticipated loads shall address the capacity of the existing structure at all phases of this work.

Where applicable, construction activities for the existing bridge(s) over roadways and railroads shall be in accordance with the Job SP "Special Safety Requirements for Bridges" and as shown in "Minimum Construction Clearance Envelope".

HYDRODEMOLITION: The entire roadway surface of the existing bridge deck and approach slabs and gutters, as applicable, shall receive hydrodemolition in accordance with the Job SP "Hydrodemolition - Class ___" to a planned depth of 1 1/2" below the existing bridge deck surface. Deteriorated concrete in the bridge deck below this depth shall be removed at the direction of the Engineer and up to the limits detailed. These areas shall be measured by the square yard and shall be paid for at the unit price bid for the Item Job SP "Hydrodemolition - Class ___". Prior to hydrodemolition, cold milling of the concrete deck to a maximum depth of 1" will be allowed unless there will be a conflict with the existing reinforcing steel.

LATEX MODIFIED CONCRETE OVERLAY: The entire area of the hydrodemolition shall receive a Latex Modified Concrete (LMC) Overlay to a planned depth of 1 1/2" below the existing bridge deck surface in accordance with Job SP "Latex Modified Concrete Overlay". These areas shall be measured by the square yard and shall be paid for at the unit price bid for the Item Job SP "Latex Modified Concrete Overlay (1 1/2" Thick)". Areas of the existing bridge deck removed at the direction of the Engineer to a depth greater than 1 1/2" below the existing bridge deck surface shall be filled with LMC concurrent to the placement of the 1 1/2" LMC Overlay. This area shall be measured and paid for in accordance with Job SP "Latex Modified Concrete Overlay".

GROOVED FINISH: The LMC Overlay surface of the bridge deck and approach slabs and gutters, as applicable, shall be given a grooved finish as specified for final finishing in Subsection 802.19 for Class 7 Grooved Bridge Roadway Surface Finish and in accordance with Job SP "Latex Modified Concrete Overlay".

PROTECTIVE SURFACE TREATMENT: The longitudinal joint between the LMC Overlay and the adjacent existing concrete curb or rail shall be given a Class 3 Protective Surface Treatment as specified in Section 803 and in accordance with Job SP "Latex Modified Concrete Overlay". The roadway surface of the completed LMC Overlay shall be given a Class 1 Protective Surface Treatment as specified in Section 803.

JOINT REHABILITATION: After the placement of the LMC Overlay and if shown in the plans, the existing armored joints shall be given a poured silicone joint sealant as specified in Section 809 and as shown in "Poured Silicone Joint Seal Details" on Standard Drawing No. 55064, and the existing unarmored joints shall be given a Type A Joint Rehabilitation as specified in Section 509 and Job SP "Joint Rehabilitation for Bridge Decks". Backwall repair, if shown in the plans or as directed by the Engineer, shall be completed prior to installation of the joint sealant.

Modified Hydrodemolition SP reference to include "- Class ___".
By: KWY, Checked by: SWP; 1/9/2020.
Modified Joint Rehabilitation to include armored joints.
By: KWY, Checked by: SWP; 6/25/2020.

NOTE: When "Very Early Strength Latex Modified Concrete Overlay (1 1/2" Thick)" is shown in the plans for a particular bridge, all reference to "Latex Modified Concrete Overlay" and "LMC" on this sheet shall be considered synonymous with "Very Early Strength Latex Modified Concrete Overlay" and "VESLMC" for that bridge. See Job SP "Very Early Strength Latex Modified Concrete Overlay" for additional information.

- Hand tools shall be used as required to remove concrete adjacent to curbs and rails.
- For staged construction, the final construction joint location shall be established by the Engineer to satisfy MOT and construction requirements. The desired location is at the C.L. Bridge, C.L. Lane, or Edge of Lane, but in no case shall be positioned in the line of a wheel path.
- For staged construction, saw cut and remove 1" of initial Latex Modified Concrete Overlay when preparing surface for adjacent overlay.
- For staged construction, Temporary Precast Barrier (TPB) shall not be connected to the surface of the bridge deck. See Std. Dwg. TC-4 for additional details. Plastic drums shall be used in lieu of concrete barriers where shown in the Roadway Plans, see Std. Dwg. TC-3 for additional details.

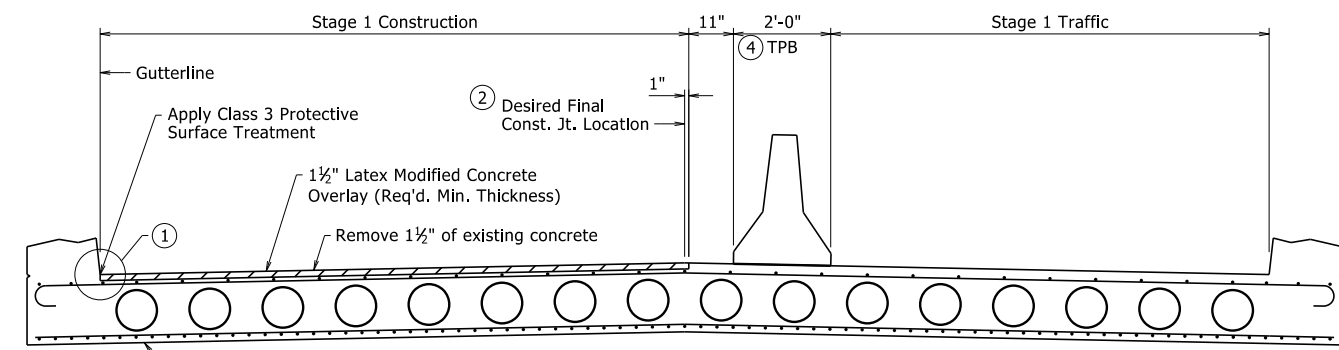

STAGE 1 LATEX MODIFIED CONCRETE OVERLAY

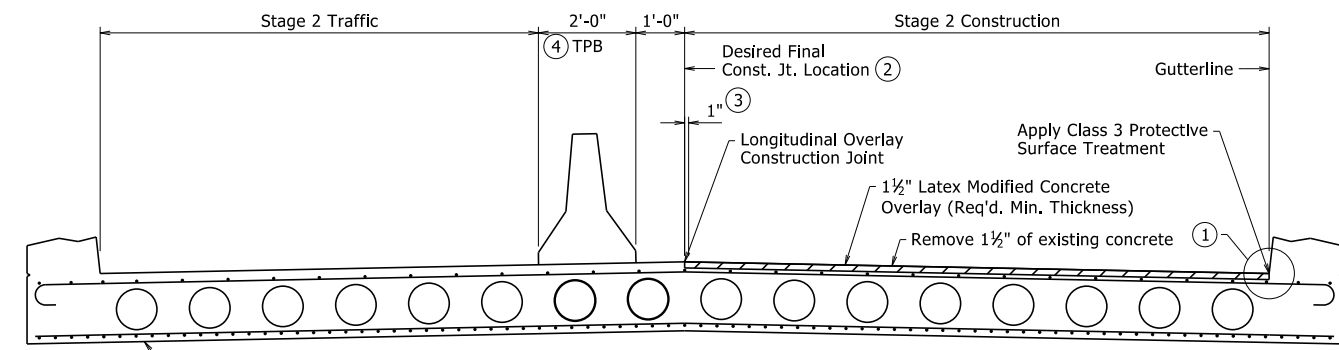

STAGE 2 LATEX MODIFIED CONCRETE OVERLAY

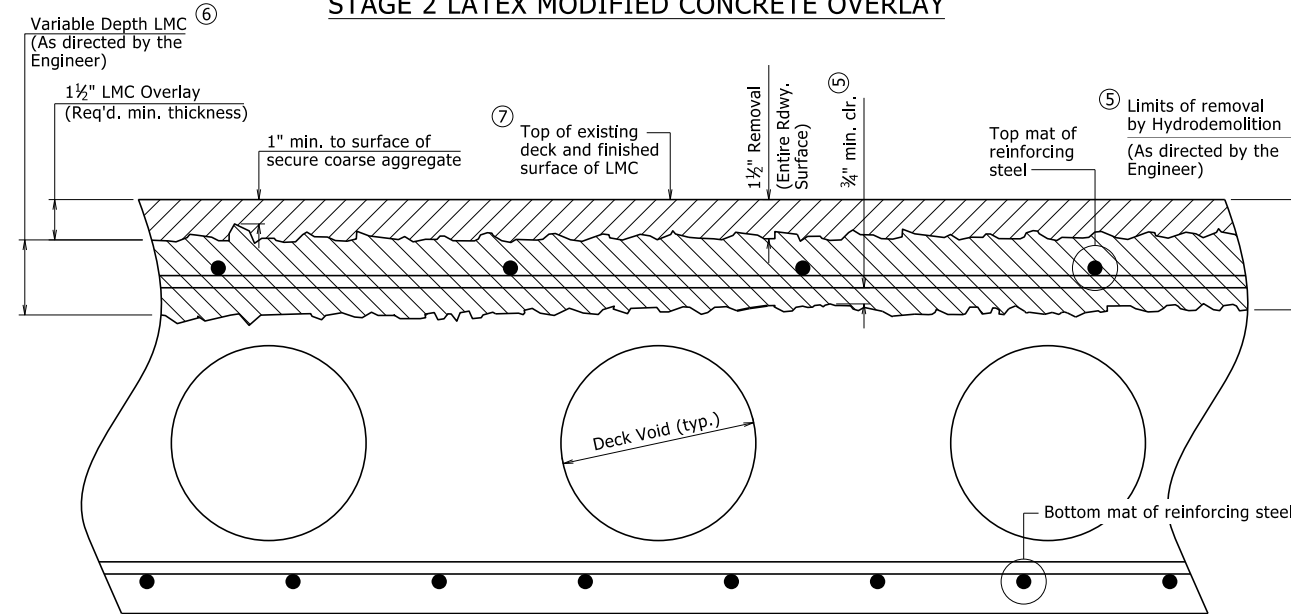

DETAILS OF HYDRODEMOLITION AND LATEX MODIFIED CONCRETE OVERLAY

- Removal of unsound concrete beyond 1 1/2" below the original surface shall be at the direction of the Engineer. If the bond between existing concrete and the top mat of reinforcing steel is destroyed, then the concrete shall be removed to a minimum of 3/4" clearance below the bar. This removal shall be subsidiary to the Item Job SP "Hydrodemolition - Class ___".
- Depth varies to achieve minimum clearance below top mat of reinforcing steel, where required.
- Finished surface of LMC Overlay shall match existing concrete deck surfaces unless increase is required to maintain minimum required LMC Overlay thickness and a minimum of 1 1/2" cover to reinforcing steel.

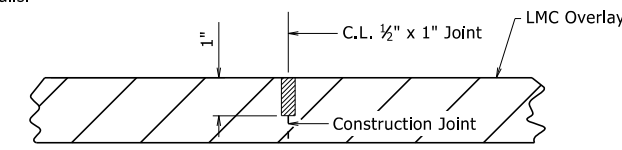

LONGITUDINAL OVERLAY CONSTRUCTION JOINT DETAIL

For Staged Construction

Use 1/2" x 1" Type 3 or 4 Joint Sealer. See Subsections 501.02(h) and 501.05(j). Backer Rod will not be required. Joint Sealer shall be measured and paid for as LMC Overlay. Longitudinal construction joints shall be sawed as soon as the concrete has sufficiently set to allow sawing of the joint without damage to the overlay. Seal color shall be gray or other color similar to concrete.

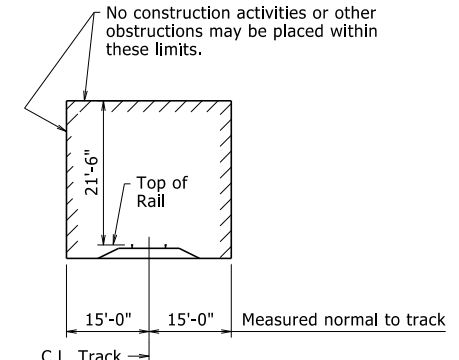

MINIMUM CONSTRUCTION CLEARANCE ENVELOPE

See Job SP "Insurance, Construction, and Flagging Requirements on Railroad Property" for additional railroad construction requirements.

If the hydrodemolition equipment blows through the deck and into a deck void, that area shall be the responsibility of the Contractor and shall be repaired at the Contractor's expense. The Contractor shall provide a method of handling unexpected blow through.

This document was originally issued and sealed by Charles R. Ellis, PE No. 9235, on November 7, 2019. This copy is not a signed and sealed document.

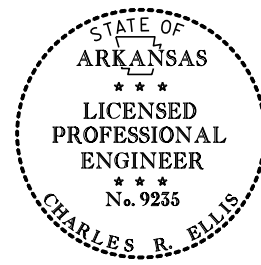

STANDARD DETAILS FOR HYDRODEMOLITION AND LMC OVERLAY VOIDED CONCRETE SLAB STRUCTURES
ARKANSAS STATE HIGHWAY COMMISSION
LITTLE ROCK, ARK.

DRAWN BY: KWY DATE: 11/7/2019 FILENAME: b55063.dgn
CHECKED BY: SWP DATE: 11/7/2019 SCALE: None
DESIGNED BY: STD. DATE: -----

DRAWING NO. 55063

PRINT DATE: 11/4/2020

BRIDGE ENGINEER

DATE REVISED	DATE FILMED	DATE REVISED	DATE FILMED	FED. ROAD DIST. NO.	STATE	FED. AID PROJ. NO.	SHEET NO.	TOTAL SHEETS
				6	ARK.			
				JOB NO.				
				1		JOINT REPAIR - 55064		

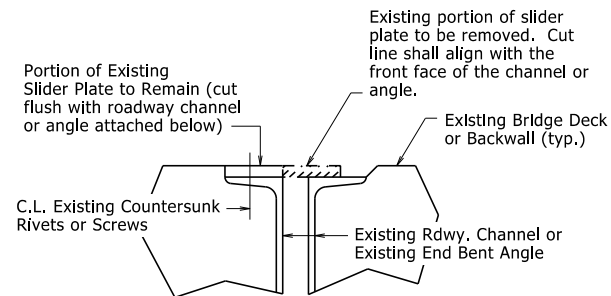

REMOVAL DETAILS AT EXISTING SLIDER PLATE JOINTS

At the direction of the Engineer, the portion of existing slider plate shown shall be removed and replaced with a new plate as shown in "SLIDER PLATE JOINT MODIFICATION". The portion of existing slider plate shall be removed and disposed of in accordance with Section 821. The cut face shall be ground square and flush with the face of the existing angle or channel. Removal and disposal of existing slider plate material will not be paid for directly, but shall be considered subsidiary to the item "Silicone Joint Sealant". Properly functioning slider plates need not be modified.

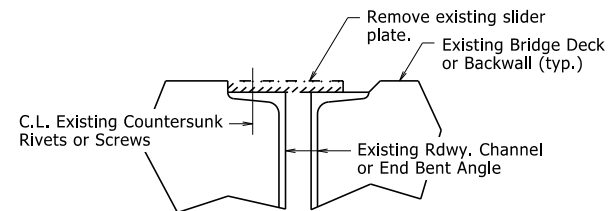

REMOVAL DETAILS AT EXISTING SLIDER PLATE JOINTS WITH GRADE RAISE

The existing slider plate shown shall be removed and replaced with new plates as shown in "JOINT MODIFICATION WITH GRADE RAISE". The existing slider plate shall be removed and disposed of in accordance with Section 821. Removal and disposal of existing slider plate material will not be paid for directly, but shall be considered subsidiary to the item "Silicone Joint Sealant".

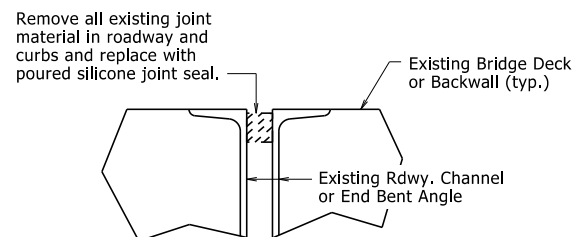

REMOVAL DETAILS AT EXISTING FILLED JOINTS

The existing joint material shall be removed and disposed of in accordance with Section 821. Removal and disposal of existing joint material will not be paid for directly, but shall be considered subsidiary to the item "Silicone Joint Sealant".

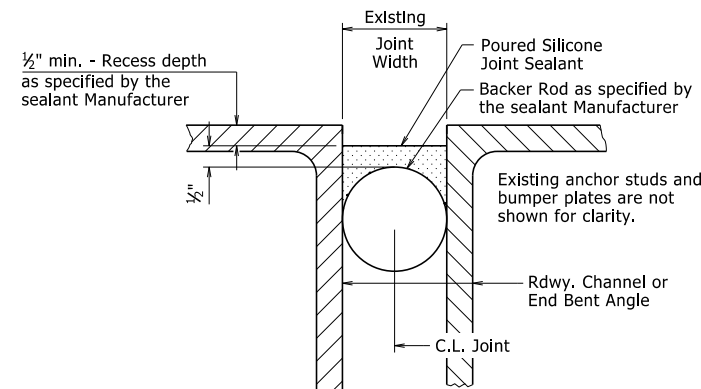

POURED SILICONE JOINT SEAL DETAILS

Existing Joint Seal shall be completely removed, backer rods placed, and Silicone Joint Sealant installed across the entire width of the bridge deck in accordance with these details, Section 809, and the Manufacturer's recommendations. Removal of existing Joint Seal will not be paid for directly, but shall be considered incidental to the item "Silicone Joint Sealant".

Backer rods shall be extended beyond the length of the poured joint in the initial joint repair area so that the two pieces can be properly spliced together prior to installing sealant for the adjacent joint repair. Manufacturer's recommendations shall be followed to prevent sealant leakage during repair work.

Backer rods shall be appropriately sized and set to the depth shown in the Manufacturer's literature based on the joint width at the time of sealing. Except as noted, do not install more backer rod than can be sealed in the same day. The Contractor shall verify separation of the backer rod from the joint material after joint material has set.

Backer rod shall be notched or otherwise fit around any existing seal supports or bumper plates to maintain its proper depth as defined above.

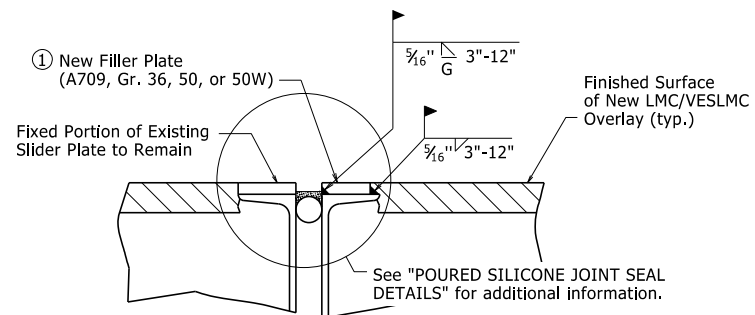

SLIDER PLATE JOINT MODIFICATION

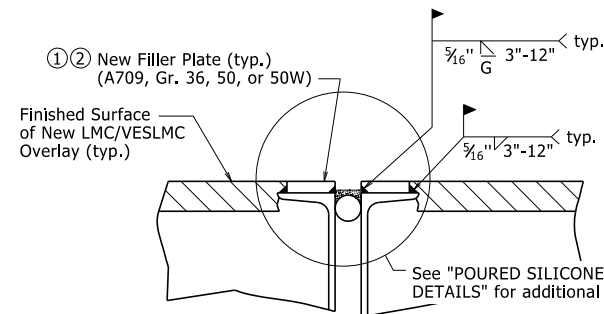

JOINT MODIFICATION WITH GRADE RAISE

1 New field attached plates atop existing roadway channels or angles are required. The plate thickness shall be adjusted as necessary to match surface of finished surface of LMC/VESLMC Overlay and the width shall be 3/8" less than the existing channel flange or angle width to allow for fillet weld as shown.

All new Structural Steel shall be ASTM A709 (Gr. 36, 50, or 50W). The surfaces not in contact with concrete shall be cleaned and painted in accordance with Section 638. Only one coat of paint is required and shall be applied in the fabricator's shop. Grade 50W steel shall not be painted, but shall be cleaned in accordance with Subsection 807.84(e). Structural Steel and Painting will not be paid for directly, but shall be subsidiary to the item "Silicone Joint Sealant".

2 Details shown are for an expansion joint where two bridge units meet. Eliminate filler plate on backwall and proceed with backwall repair in accordance with "BACKWALL REPAIR REMOVAL DETAIL" and "BACKWALL REPAIR INSTALLATION DETAIL" at end bents for bridge decks with grade raise, see Standard Drawing Number 55065.

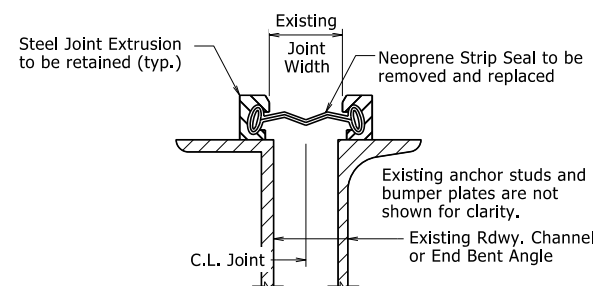

STRIP SEAL JOINT DETAILS

Existing neoprene strip seal joint material shall be completely removed and new neoprene strip seal joint material shall be installed across the entire width of the steel extrusions in accordance with these details, Section 809, and the Manufacturer's recommendations. Prior to installing the new joint material, the Contractor shall clean the steel extrusion at the Engineer's direction and in accordance with the new strip seal joint material Manufacturer's recommendations.

Removal and replacement of the existing neoprene strip seal joint material will require the removal of the parapet slider plates, where present. Parapet slider plates removed for this work shall be reinstalled after installation of the new neoprene strip seal joint material.

The new neoprene strip seal joint material shall provide a movement rating of four inches. The repaired expansion joint shall be capable of sealing the deck surface and parapet area to prevent moisture and other contaminants from descending through the joint.

All work and material associated with removing the existing joint material, cleaning the extrusions, removal and reinstallation of parapet slider plates, and installation of new joint material shall be paid for under the item "Modification of Existing Bridge Structure (Bridge No. _)".

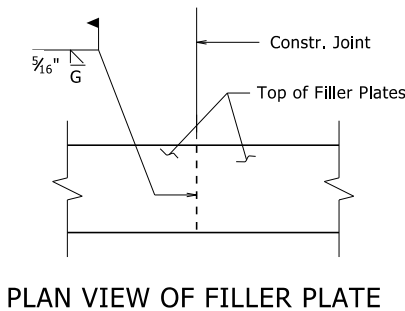

PLAN VIEW OF FILLER PLATE

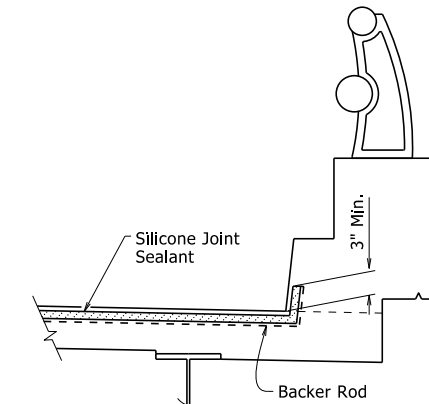

SILICONE JOINT SEAL PLACEMENT AT CURB

Vertical joints may require forming. The clearance from deck surface to joint material shall be maintained.

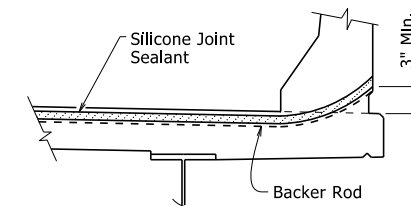

SILICONE JOINT SEAL PLACEMENT AT RAIL

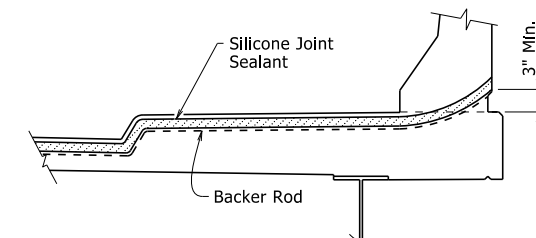

SILICONE JOINT SEAL PLACEMENT AT SIDEWALK

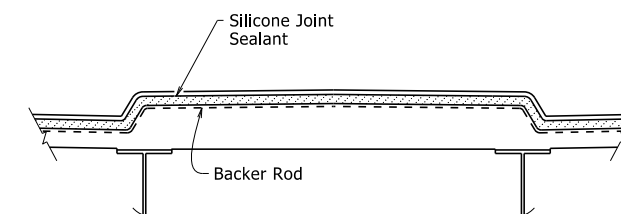

SILICONE JOINT SEAL PLACEMENT AT MEDIAN

This document was originally issued and sealed by Charles R. Ellis, PE No. 9235, on November 7, 2019. This copy is not a signed and sealed document.

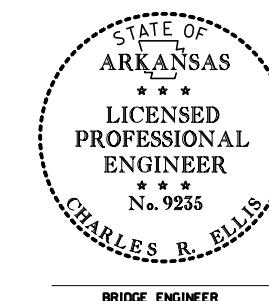

STANDARD DETAILS FOR JOINT REPAIRS & MODIFICATIONS
ARKANSAS STATE HIGHWAY COMMISSION

LITTLE ROCK, ARK.
DRAWN BY: KWW DATE: 11/7/2019 FILENAME: b55064.dgn
CHECKED BY: SWP DATE: 11/7/2019 SCALE: None
DESIGNED BY: STD. DATE: -----

DRAWING NO. 55064

DATE REVISED	DATE FILMED	DATE REVISED	DATE FILMED	FED. ROAD DIST. NO.	STATE	FED. AID PROJ. NO.	SHEET NO.	TOTAL SHEETS
				6	ARK.			
				JOB NO. BACKWALL REPAIR - 55065				

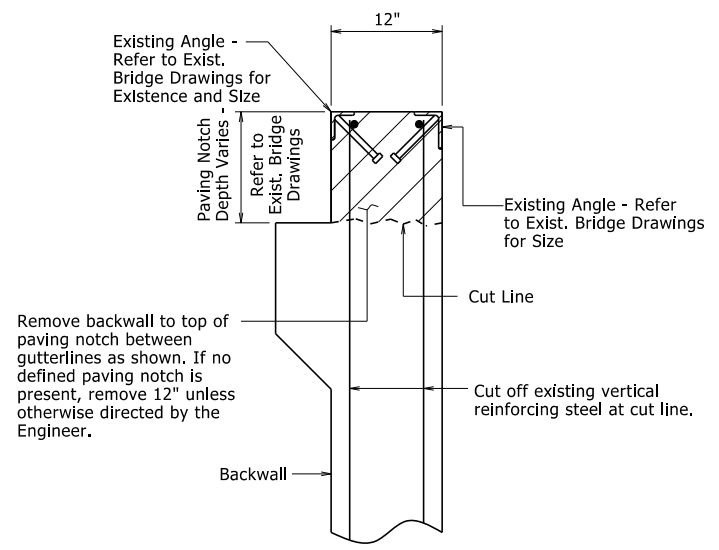

BACKWALL REPAIR REMOVAL DETAIL

The portion of the backwall above the paving bracket as shown shall be removed and disposed of in accordance with Section 821. Payment for all materials, labor, tools, and equipment required for this work will be inclusive to the item "Modification of Existing Bridge Structure (Bridge No. _)".

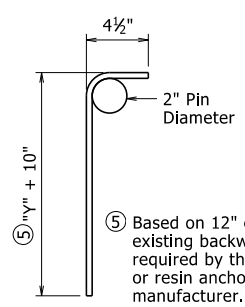

NO. 4 L-BAR

⑤ Based on 12" embedment into existing backwall, modify if required by the non-shrink grout or resin anchoring system manufacturer.

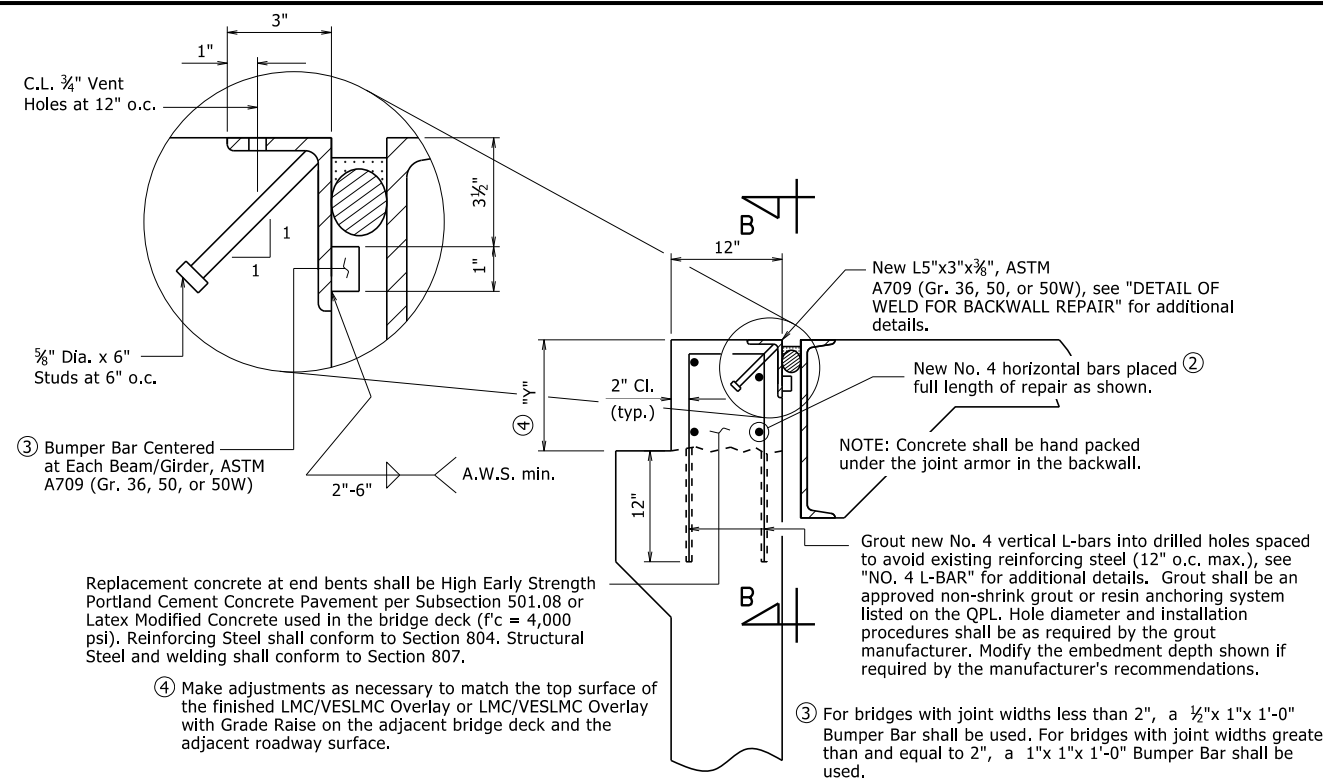

BACKWALL REPAIR INSTALLATION DETAIL

The portion of the backwall above the paving bracket shall be reconstructed as shown. Payment for all materials, labor, tools, and equipment required for this work will be inclusive to the item "Modification of Existing Bridge Structure (Bridge No. _)". Details shown for LMC/VESLMC Overlay with grade raise; details similar for LMC/VESLMC Overlay without grade raise.

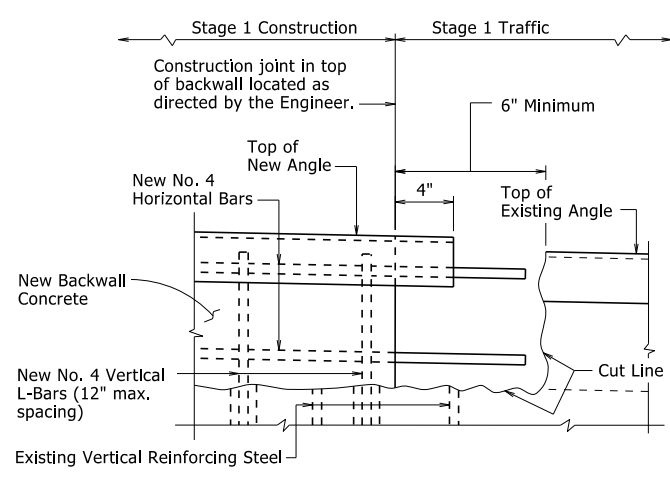
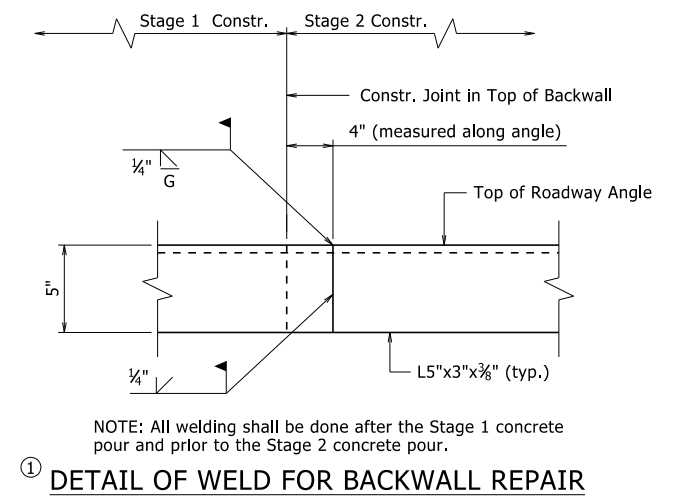

VIEW B-B, STAGE 1

Details shown for LMC/VESLMC Overlay with grade raise; details similar for LMC/VESLMC Overlay without grade raise.

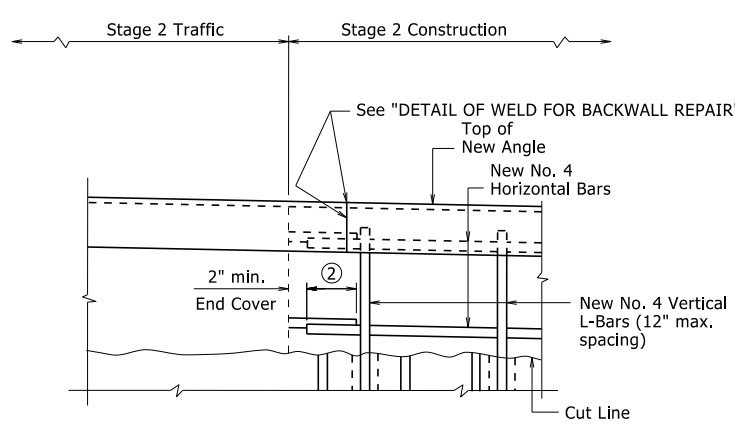

VIEW B-B, STAGE 2

- ① Details shown are typical for staged construction. When full width rehabilitation of a bridge deck is possible, eliminate construction joint shown and perform the backwall repair in one operation for full repair width.
- ② The 32 bar diameter minimum lap per Subsection 804.07 may be waived if this requirement cannot be met due to construction conditions. In this situation, the lap length shall be maximized as much as practical.

This document was originally issued and sealed by Charles R. Ellis, PE No. 9235, on November 7, 2019. This copy is not a signed and sealed document.

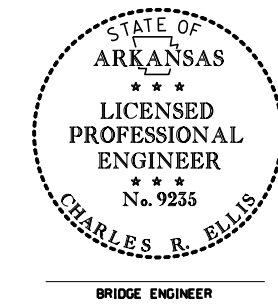

STANDARD DETAILS FOR BACKWALL REPAIRS
 ARKANSAS STATE HIGHWAY COMMISSION
 LITTLE ROCK, ARK.
 DRAWN BY: KWY DATE: 11/7/2019 FILENAME: b55065.dgn
 CHECKED BY: SWP DATE: 11/7/2019 SCALE: None
 DESIGNED BY: STD. DATE: -----
 DRAWING NO. 55065

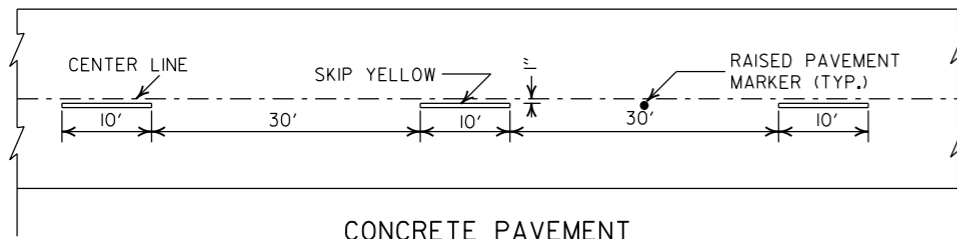

CONCRETE PAVEMENT

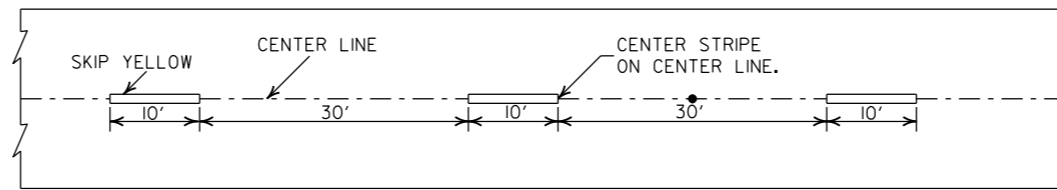

ASPHALT PAVEMENT

BROKEN LINE STRIPING

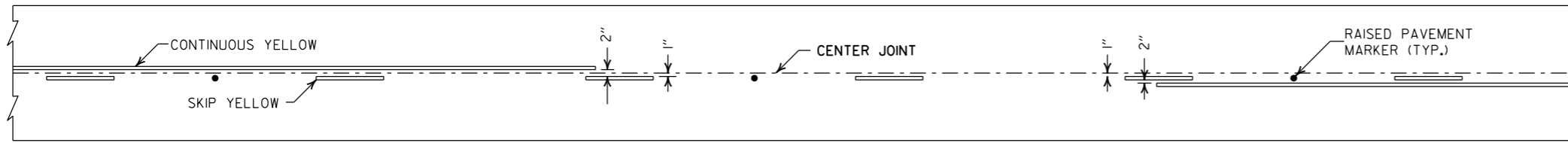

SOLID LINE STRIPING ON CONCRETE PAVEMENT

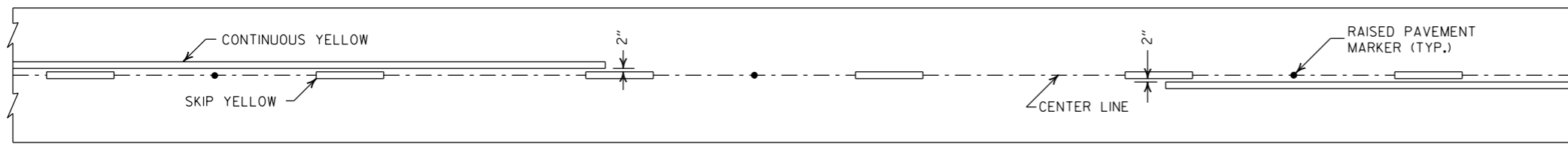

SOLID LINE STRIPING ON ASPHALT PAVEMENT

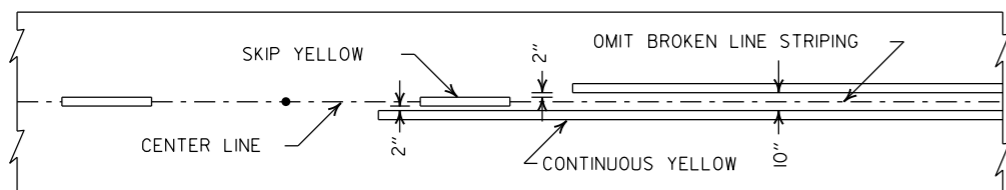

ASPHALT PAVEMENT

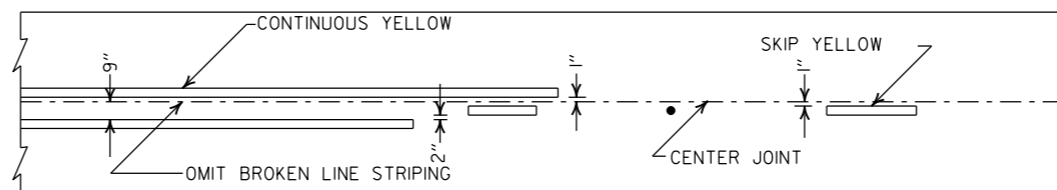

CONCRETE PAVEMENT

STRIPING AT ADJACENT NO PASSING LANES

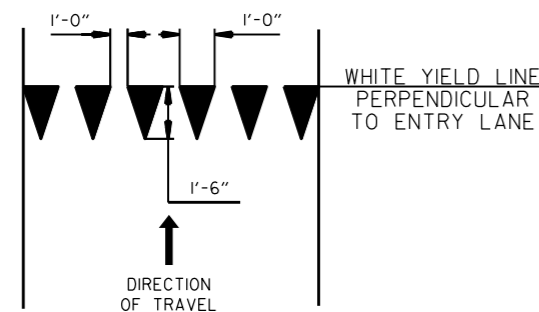

YIELD LINE DETAIL

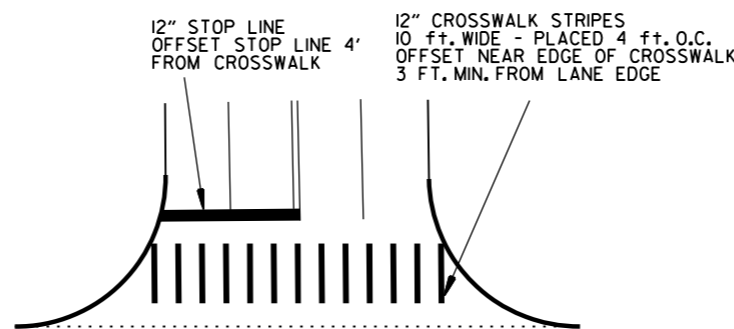

CROSSWALK AND STOP LINE DETAILS

- NOTES:
- REFER TO THE STRIPING DETAILS FOR PAVEMENT MARKING LINE WIDTHS.
 - THIS DRAWING SHALL BE USED IN CONJUNCTION WITH THE LATEST REVISED ADDITION OF THE "MANUAL ON UNIFORM TRAFFIC CONTROL DEVICES."
 - RAISED PAVEMENT MARKERS SHALL BE PLACED ON AN 80 FEET SPACING UNLESS OTHERWISE SHOWN IN THE PLANS.

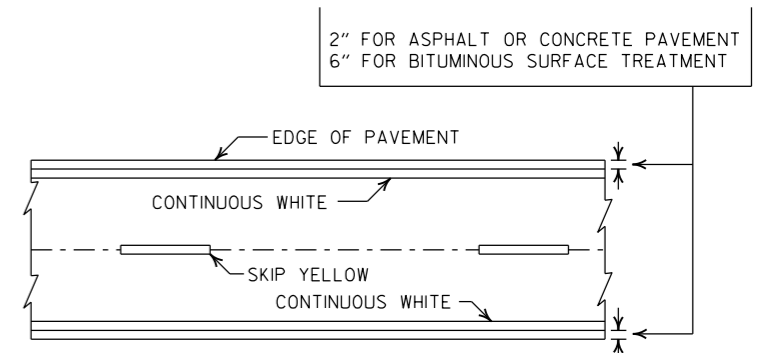

PAVEMENT EDGE LINE MARKING

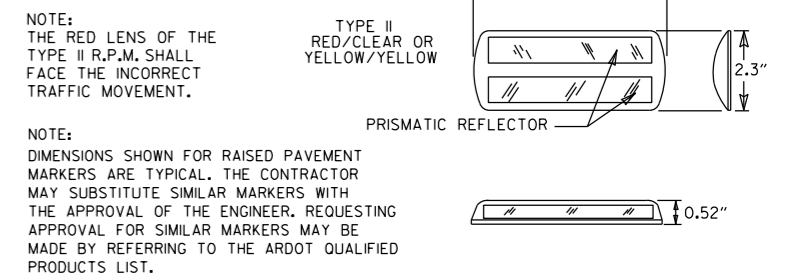











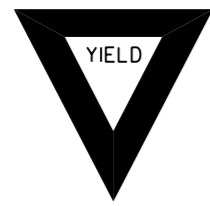







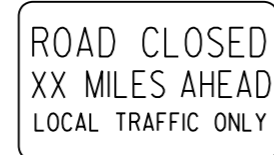
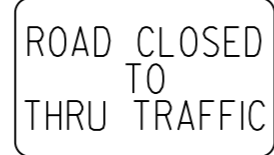

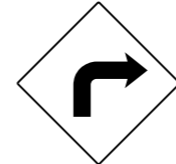



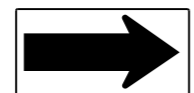

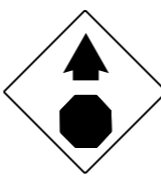
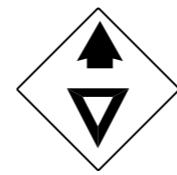
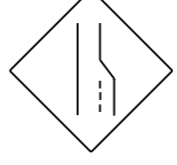









DETAIL OF STANDARD RAISED PAVEMENT MARKERS

DATE	REVISION	FILMED
2-27-20	REVISED STOP LINE DETAILS	
6-1-17	ADDED YIELD LINE DETAIL	
5-12-16	REVISED LINE WIDTHS, SPACING, & NOTES	
9-12-13	REVISED DETAIL OF STANDARD RAISED PAVEMENT MARKERS	
11-17-10	REVISED GENERAL NOTES & REMOVED PLOWABLE PVMT MRKRS	
11-18-04	REVISED NOTE 2 & GENERAL NOTES	
8-22-02	ADDED CROSSWALK & STOPBAR DTL.	
7-02-98	ADDED DETAILS OF STD. RAISED PAV'T. MARKERS	
4-26-96	REV. NOTES 3&4; ADDED R.P.M.	
9-30-80	DRAWN	1-9-30-80

ARKANSAS STATE HIGHWAY COMMISSION

PAVEMENT MARKING DETAILS

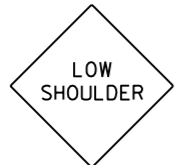
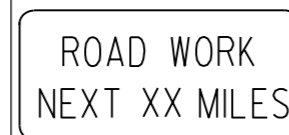
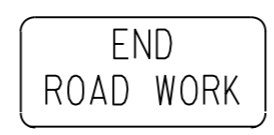
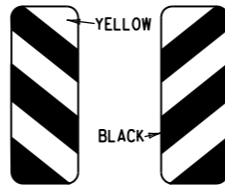
STANDARD DRAWING PM-1

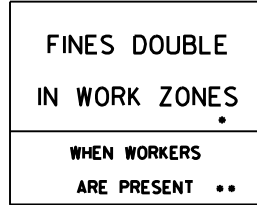
<p>RI-1</p>  <p>STANDARD 30"x30" EXPRESSWAY 36"x36" SPECIAL 48"x48"</p>	<p>RI-2</p>  <p>STD. 36"x36"x36" EXPWY. 48"x48"x48" FWY. 60"x60"x60"</p>	<p>R2-1</p>  <p>STD. 24"x30" EXPWY. 36"x48" FWY. 48"x60"</p>	<p>W3-5</p>  <p>STD. 36"x36" EXPWY. 48"x48" FWY. 48"x48"</p>	<p>W3-5a</p>  <p>STD. 36"x36" EXPWY. 48"x48" FWY. 48"x48"</p>	<p>R4-1</p>  <p>STD. 24"x30" EXPWY. 36"x48" FWY. 48"x60"</p>	<p>R4-2</p>  <p>STD. 24"x30" EXPWY. 36"x48" FWY. 48"x60"</p>	
<p>R5-1</p>  <p>STD. 30"x30" EXPWY. 36"x36" SPECIAL 48"x48"</p>	<p>R11-2</p>  <p>48"x30"</p>	<p>R11-3A</p>  <p>60"x30"</p>	<p>R11-4</p>  <p>60"x30"</p>	<p>W21-5a</p>  <p>STD. 36"x36" FWY. 48"x48"</p>	<p>WI-1</p>  <p>STD. 36"x36" FWY. 48"x48"</p>	<p>WI-2</p>  <p>STD. 36"x36" FWY. 48"x48"</p>	
<p>WI-3</p>  <p>STD. 48"x48"</p>	<p>WI-4</p>  <p>STD. 48"x48"</p>	<p>WI-6</p>  <p>STD. 48"x24" SPECIAL 60"x30"</p>	<p>WI-8</p>  <p>STD. 18"x24" SPECIAL 24"x30" EXPWY. 30"x36" FWY. 36"x48"</p>	<p>W3-1</p>  <p>STD. 36"x36" SPECIAL 48"x48"</p>	<p>W3-2</p>  <p>STD. 36"x36" SPECIAL 48"x48"</p>	<p>W4-2</p>  <p>STD. 36"x36" FWY. 48"x48"</p>	
<p>W5-1</p>  <p>STD. 36"x36" SPECIAL 48"x48"</p>	<p>W6-3</p>  <p>EXPWY. 36"x36" SPECIAL 48"x48"</p>	<p>W8-7</p>  <p>EXPWY. 36"x36" FWY. 48"x48"</p>	<p>W9-2</p>  <p>STD. 36"x36" FWY. 48"x48"</p>	<p>W13-1</p>  <p>STD. 24"x24"</p>	<p>W20-1</p>  <p>STD. 48"x48"</p>	<p>W20-2</p>  <p>STD. 48"x48"</p>	<p>W20-3</p>  <p>STD. 48"x48"</p>
<p>W20-4</p>  <p>STD. 48"x48"</p>	<p>W20-5</p>  <p>STD. 48"x48"</p>	<p>W20-7a</p>  <p>18" 500 FEET 24" W16-2</p> <p>STD. 36"x36" FWY. 48"x48"</p>	<p>W21-2</p>  <p>STD. 30"x30" SPECIAL 36"x36"</p>	<p>W21-5</p>  <p>STD. 30"x30" SPECIAL 36"x36"</p>	<p>W24-1</p>  <p>STD. 36"x36"</p>	<p>WI-4b</p>  <p>STD. 48"x48"</p>	<p>R56-1</p>  <p>STD. 18"x18"</p>
<p>W8-11</p>  <p>STD. 36"x36" FWY. 48"x48"</p>	<p>W8-9</p>  <p>STD. 36"x36" FWY. 48"x48"</p>	<p>G20-1</p>  <p>60"x24"</p>	<p>G20-2</p>  <p>48"x24"</p>	<p>OM-3L OM-3R</p>  <p>12"x36"</p>	<p>M4-9</p>  <p>STD. 30"x24" SPECIAL 48"x36" SPECIAL 60"x48"</p>	<p>M4-10</p>  <p>48"x18"</p>	<p>R55-1</p>  <p>36"x60"</p> <p>• USE 6" C LETTERS •• USE 4" D LETTERS</p>

ADVANCE DISTANCES
(XXXX)

500 FT	1/2 MILE
1000 FT	3/4 MILE
1500 FT	1 MILE AHEAD

GENERAL NOTES:

- ALL TRAFFIC CONTROL DEVICES USED ON ROAD CONSTRUCTION SHALL CONFORM TO THE MANUAL ON UNIFORM TRAFFIC CONTROL DEVICES, LATEST EDITION, AND TO THE STANDARD HIGHWAY SIGNS, LATEST EDITION, OR AS APPROVED BY THE FEDERAL HIGHWAY ADMINISTRATION.
- TRAFFIC CONTROL DEVICES SHALL BE SET UP JUST BEFORE THE START OF CONSTRUCTION OPERATIONS AND SHALL BE PROPERLY MAINTAINED DURING THE TIME SUCH CONDITIONS EXIST. THEY SHALL REMAIN IN PLACE ONLY AS LONG AS NEEDED AND REMOVED THEREAFTER.
- EXISTING SIGNS AND CONSTRUCTION SIGNS SHALL BE KEPT IN PROPER POSITION, AND BE CLEAN AND LEGIBLE AT ALL TIMES. SIGNS THAT DO NOT APPLY TO EXISTING CONDITIONS SHALL BE REMOVED. SIGNS THAT ARE DAMAGED, DEFACED, OR THAT ACCUMULATE DIRT DURING CONSTRUCTION SHALL BE CLEANED, REPAIRED, OR REPLACED.
- SIGNS ARE USUALLY MOUNTED ON A SINGLE POST, ALTHOUGH THOSE WIDER THAN 36" OR LARGER THAN 10 SQ. FT. SHALL BE MOUNTED ON TWO POSTS OR ABOVE A TYPE III BARRICADE.
- SIGN POSTS DIRECT BURIED IN SOIL SHALL BE 2 LB. MINIMUM CHANNEL POST OR 4"x4" WOOD POSTS. CHANNEL POSTS SHALL BE PAINTED GREEN. WOOD POSTS SHALL BE PAINTED WHITE. ALL POSTS SHALL BE NEATLY CONSTRUCTED, AND SHALL BE REPLUMBED, CLEANED, OR REPAIRED AS NEEDED FOR THE DURATION OF THE JOB. THERE SHALL NOT BE MORE THAN 2 POSTS IN A 7' PATH FOR WOOD OR CHANNEL POSTS. ANY CHANNEL POST SPLICE SHALL BE IN ACCORDANCE WITH STANDARD DRAWING TC-3.
- POST MOUNTED SIGNS IN RURAL AREAS SHALL BE CONSTRUCTED WITH THE NEAR EDGE OF THE SIGN FROM 6 TO 12 FEET FROM THE PAVEMENT EDGE. SIGNS IN URBAN AREAS AND BARRICADE MOUNTED SIGNS SHALL BE MOUNTED A MINIMUM OF 2 FEET FROM THE PAVEMENT EDGE.
- ALL POST AND BARRICADE MOUNTED SIGNS MOUNTED IN URBAN AREAS SHALL BE MOUNTED A MINIMUM DISTANCE OF 7' FROM THE BOTTOM OF THE SIGN TO THE ROADWAY SURFACE. ALL POST AND BARRICADE MOUNTED SIGNS MOUNTED IN RURAL AREAS SHALL BE MOUNTED A MINIMUM DISTANCE OF 7' FROM THE BOTTOM OF THE SIGN TO THE ROADWAY SURFACE, EXCEPT A MINIMUM OF 6' SHALL BE USED WHEN MOUNTING AN ADVISORY SIGN BELOW A WARNING SIGN. TEMPORARY SIGNS MAY BE MOUNTED ON PORTABLE SUPPORTS FOR INTERMEDIATE TERM STATIONARY WORK CONDITIONS. THE SIGNS MINIMUM MOUNTING HEIGHT SHALL BE 5'. RETROREFLECTIVE DEVICES SHALL BE USED. TEMPORARY SIGNS MAY BE MOUNTED ON PORTABLE SUPPORTS FOR SHORT-TERM, SHORT DURATION, AND MOBILE CONDITIONS. THEY SHALL BE NO LESS THAN ONE (1) FOOT ABOVE THE TRAVELED WAY. LONG-TERM STATIONARY SIGNS SHALL BE DIRECT BURIED IN SOIL, UNLESS CONDITIONS NECESSITATE THE USE OF PORTABLE SIGNS, OR AS APPROVED BY THE ENGINEER. CONCRETE PADS, CONCRETE OR ROCK BALLAST, OR OTHER SOLID MATERIALS SHALL NOT BE UTILIZED WITH PORTABLE SIGN SUPPORTS.
- FLAGGERS SHALL USE REFLECTORIZED STOP-SLOW PADDLES. FLAGS MAY BE USED ONLY FOR EMERGENCY SITUATIONS.
- MOST OF THE SIGNS SHOWN ARE ORIENTED TO THE RIGHT. HOWEVER, THIS DOES NOT PRECLUDE THE USE OF MIRROR IMAGES OF THESE SIGNS WHERE THE REVERSE ORIENTATION MIGHT BETTER CONVEY TO MOTORISTS THE PROPER DIRECTION OF MOVEMENT.
- R55-1 SIGNS SHALL BE PLACED AT LEAST 1500' BUT NOT MORE THAN 1 MILE IN ADVANCE OF THE WORK ZONE. IF A SPEED LIMIT REDUCTION IS IN EFFECT, THE SIGN SHALL BE PLACED A MINIMUM OF 500' IN ADVANCE OF THE "REDUCED SPEED AHEAD" SIGN.

• NOTE: SUPPORTS FOR SIGNS, BARRICADES, AND VERTICAL PANELS THAT ARE DIFFERENT FROM THE REQUIREMENTS SHOWN IN NOTES 4 & 5, BUT MEET THE REQUIREMENTS OF MANUAL FOR ASSESSING SAFETY HARDWARE (MASH), WILL BE ACCEPTED. COMPLIANCE WITH THE REQUIREMENTS OF MANUAL FOR ASSESSING SAFETY HARDWARE (MASH) IS REQUIRED FOR ALL PROJECTS.

DATE	REVISION	FILMED
11-07-19	REVISED FOR MASH	
4-13-17	DELETED RSP-1 & ADDED W21-5a	
9-2-15	REVISED REDUCED SPEED LIMIT AHEAD SIGNS REVISED ROAD WORK NEXT XX MILES	
12-15-11	REVISED W24-1	
11-17-10	DELETED W8-9a & ADDED W8-9	
10-15-09	ADDED REFERENCE TO MASH & ADDED SIGN W24-1	
4-17-08	REVISED SIGN DESIGNATIONS	
11-18-04	REVISED NOTES	
10-9-03	REVISED NOTE 1	
11-16-01	REVISED NOTE 7	
9-28-00	REVISED NOTE	
11-18-98	ADDED NOTE	
6-26-97	REVISED NOTE 5	
4-03-97	REVISED NOTE 5	
10-18-96	ADDED CONTROLLED ACCESS HWY. SIGN & TO NOTE 7	
10-12-95	ADDED R55-1	
6-8-95	REVISED TO CORRECT SIGN ILLUSTRATIONS	6-8-95
2-2-95	REVISED PER PART VI, MUTCD SEPT. 3, 1993	
8-15-91	DRAWN AND PLACED IN USE	

ARKANSAS STATE HIGHWAY COMMISSION
STANDARD TRAFFIC CONTROLS
FOR HIGHWAY CONSTRUCTION
STANDARD DRAWING TC-1

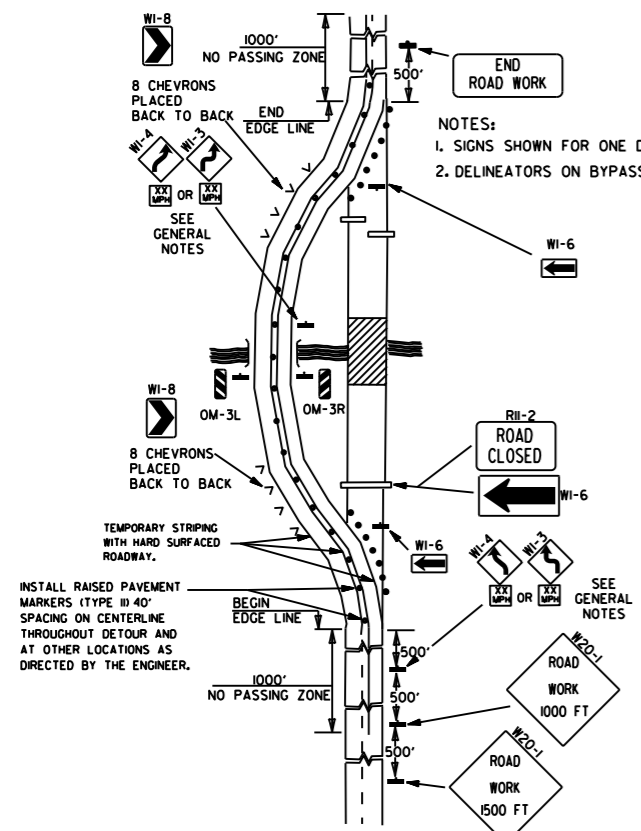

(A) TYPICAL APPLICATION OF TRAFFIC CONTROL DEVICES ON A 2-LANE HIGHWAY WHERE THE ENTIRE ROADWAY IS CLOSED AND A BYPASS DETOUR IS PROVIDED.

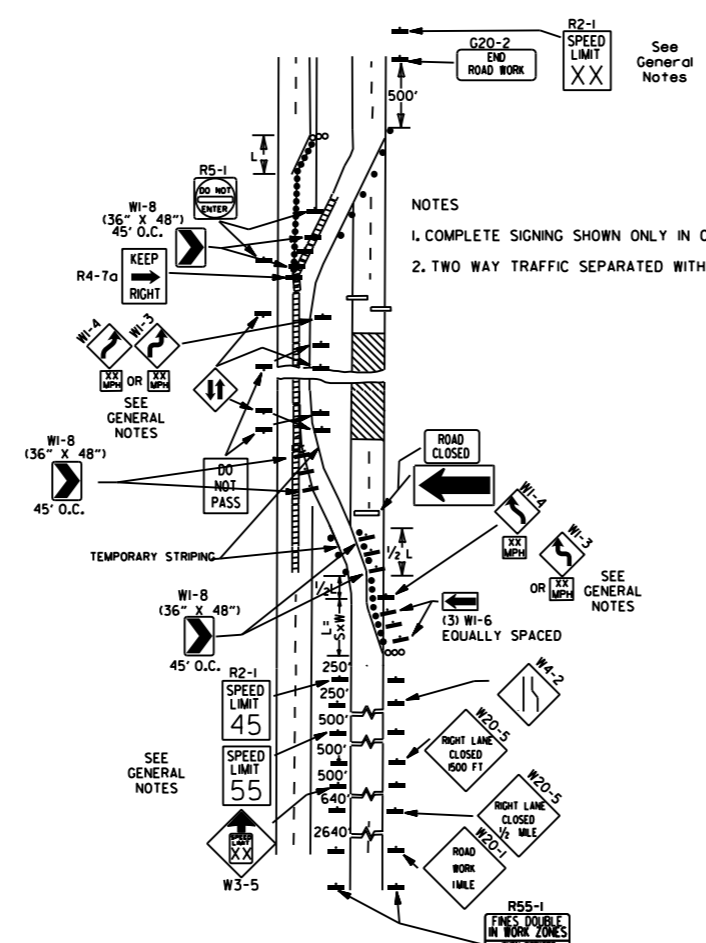

(B) TYPICAL APPLICATION - 4-LANE DIVIDED ROADWAY WHERE ONE ROADWAY IS CLOSED.

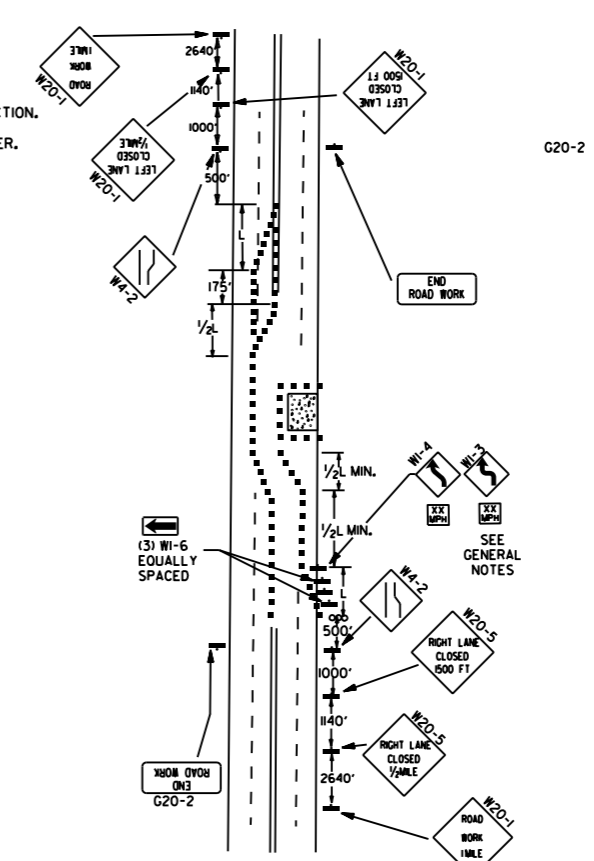

(C) TYPICAL APPLICATION - 4-LANE UNDIVIDED ROADWAY WHERE HALF OF THE ROADWAY IS CLOSED.

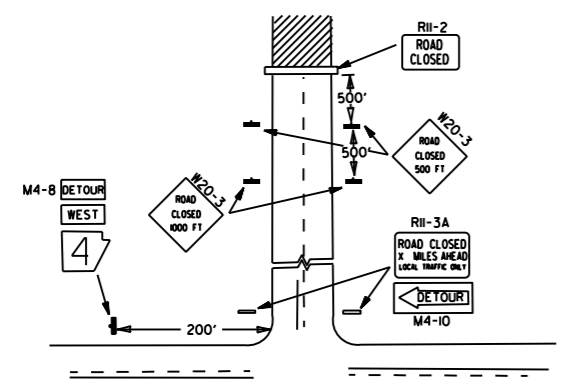

(D) TYPICAL APPLICATION - ROADWAY CLOSED BEYOND DETOUR POINT.

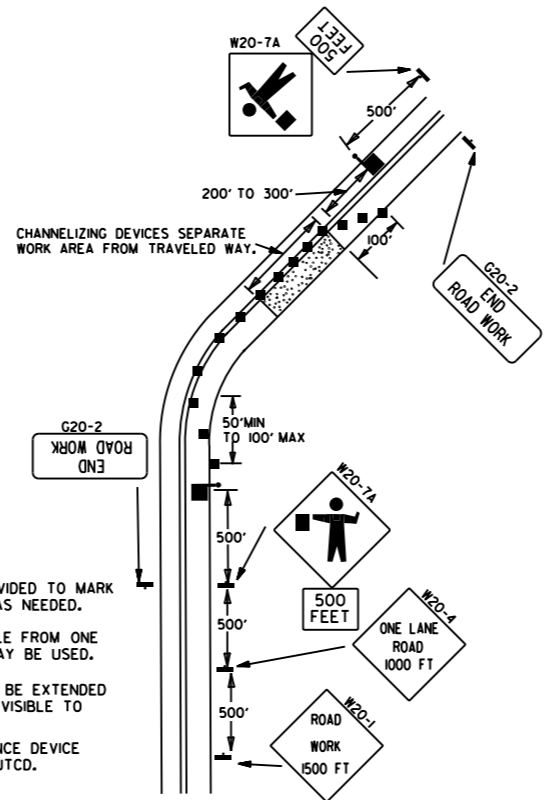

(E) TYPICAL APPLICATION OF TRAFFIC CONTROL DEVICES ON 2-LANE HIGHWAY WHERE ONE LANE IS CLOSED AND FLAGGING IS PROVIDED.

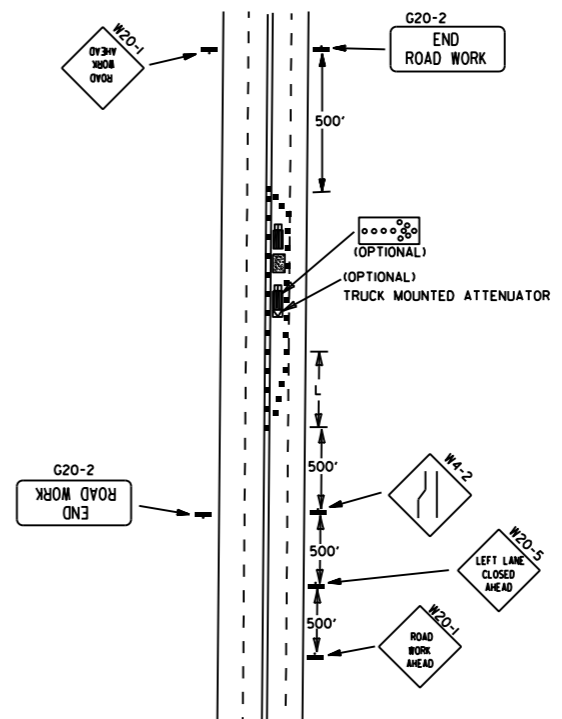

(F) TYPICAL APPLICATION - 4-LANE UNDIVIDED ROADWAY WITH INSIDE LANE CLOSED.

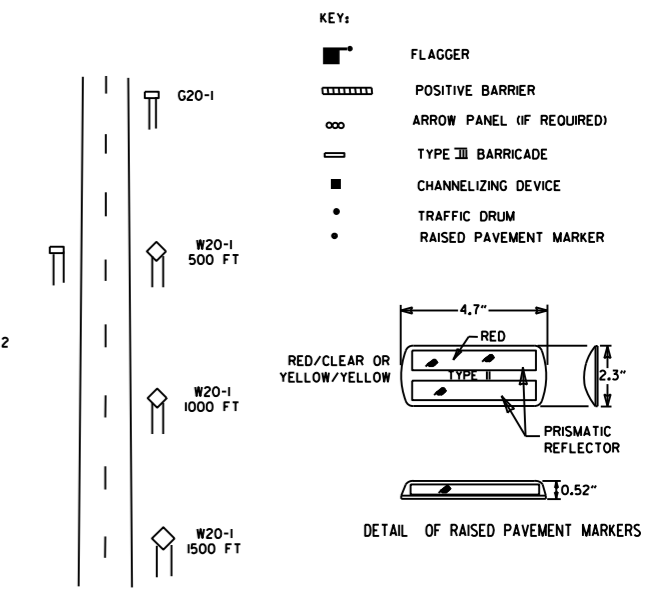

TYPICAL ADVANCE WARNING SIGN PLACEMENT
 TAPER FORMULAE:
 $L = SXW$ FOR SPEEDS OF 45MPH OR MORE.
 $L = \frac{WS^2}{60}$ FOR SPEEDS OF 40MPH OR LESS.
 WHERE:
 L = MINIMUM LENGTH OF TAPER.
 S = NUMERICAL VALUE OF POSTED SPEED LIMIT PRIOR TO WORK OR 85TH PERCENTILE SPEED.
 W = WIDTH OF OFFSET.

- GENERAL NOTES:
1. THE MAINTENANCE DIVISION SHALL CONDUCT A BALL BANK STUDY TO DETERMINE THE ADVISORY SPEED LIMIT PRIOR TO OPENING TO TRAFFIC. THE ADVISORY SPEED WILL BE POSTED ON W1-3 OR W1-4 CURVE WARNING SIGNS. USE W1-4 WHEN SPEED IS GREATER THAN 30MPH AND W1-3 WHEN 30MPH OR LESS.
 2. WHEN THE EXISTING SPEED LIMIT IS 55MPH AND THE PLANS REQUIRE A SPEED LIMIT OF 45MPH, THE R2-1(K55) SHALL BE OMITTED AND THE W3-5 SHALL BE INSTALLED AT THAT LOCATION. ADDITIONAL R2-1(45MPH) SPEED LIMIT SIGNS SHALL BE INSTALLED AT A MAXIMUM OF 1MILE INTERVALS. AT THE END OF THE WORK AREA A R2-1(KXX) SHALL BE INSTALLED TO MATCH ORIGINAL SPEED LIMIT.
 3. WHEN THE EXISTING SPEED LIMIT IS 65MPH AND THE PLANS REQUIRE A SPEED LIMIT OF 55MPH, THE R2-1(K65) SHALL BE OMITTED. ADDITIONAL R2-1(55MPH) SPEED LIMIT SIGNS SHALL BE INSTALLED AT A MAXIMUM OF 1MILE INTERVALS. AT THE END OF THE WORK AREA A R2-1(KXX) SHALL BE INSTALLED TO MATCH ORIGINAL SPEED LIMIT.
 4. THE MAXIMUM SPACING BETWEEN CHANNELIZING DEVICES IN A TAPER SHOULD BE APPROXIMATELY EQUAL IN FEET TO THE SPEED LIMIT. BEYOND THE TAPER, MAXIMUM SPACING SHALL BE TWO TIMES THE SPEED LIMIT, OR AS DIRECTED BY THE ENGINEER.
 5. WARNING LIGHTS AND/OR FLAGS MAY BE MOUNTED TO SIGNS OR CHANNELIZING DEVICES AT NIGHT AS NEEDED.
 6. PAVEMENT MARKINGS NO LONGER APPLICABLE WHICH MIGHT CREATE CONFUSION IN THE MINDS OF VEHICLE OPERATORS SHALL BE REMOVED OR OBLITERATED AS SOON AS PRACTICABLE.
 7. TRAILER MOUNTED DEVICES SUCH AS ARROW PANELS AND PORTABLE CHANGEABLE MESSAGE SIGNS SHALL BE DELINEATED BY AFFIXING CONSPICUITY MATERIAL IN A CONTINUOUS LINE ON THE FACE OF THE TRAILER, WHEN PLACED ON OR ADJACENT TO THE SHOULDER AND NOT BEHIND A POSITIVE BARRIER, THESE DEVICES SHALL BE DELINEATED BY PLACING FIVE (5) TRAFFIC DRUMS, EQUALLY SPACED ALONG THE TRAFFIC SIDE OF THE DEVICE. PAYMENT FOR TRAFFIC DRUMS SHALL BE CONSIDERED INCLUDED IN THE PRICE BID FOR VARIOUS TRAILER MOUNTED DEVICES.
 8. DIMENSIONS SHOWN FOR RAISED PAVEMENT MARKERS ARE TYPICAL. THE CONTRACTOR MAY SUBSTITUTE SIMILAR MARKERS WITH THE APPROVAL OF THE ENGINEER. REQUESTING APPROVAL FOR SIMILAR MARKERS MAY BE MADE BY REFERRING TO THE ARDOT QUALIFIED PRODUCTS LIST.
 9. ALL TRAILER MOUNTED DEVICES SUCH AS ARROW PANELS AND PORTABLE CHANGEABLE MESSAGE SIGNS SHALL MEET THE REQUIREMENTS OF THE MANUAL FOR ASSESSING SAFETY HARDWARE (MASH).

DATE	REVISION	FILMED
05-20-21	REVISED NOTE 7	
11-07-19	REVISED NOTE 1, ADDED NOTE 9	
9-2-15	REVISED NOTE 2, ADDED NOTE 8, REVISED DRAWING (A) & REPLACED R2-5A WITH W3-5	
9-12-13	REVISED DETAIL OF RAISED PAVEMENT MARKERS	
3-11-10	ADDED (AFAD)	
11-20-08	REVISED SIGN DESIGNATIONS	
11-18-04	ADDED GENERAL NOTE	
10-18-96	ADDED R55-1	
4-26-96	CORRECTED (a) BEHIND G20-2	
6-8-95	CORRECTED SIGN IDENT. ON W1-4A	6-8-95
2-2-95	REVISED PER PART VI, MUTCD, SEPT. 3, 1993	
8-15-91	DRAWN AND PLACED IN USE	

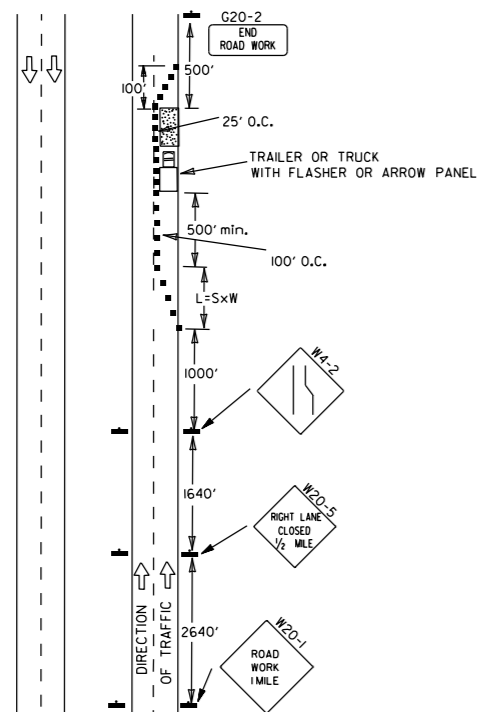

(A) TYPICAL APPLICATION - DAYTIME MAINTENANCE OPERATIONS OF SHORT DURATION ON A 4-LANE DIVIDED ROADWAY WHERE HALF OF THE ROADWAY IS CLOSED.

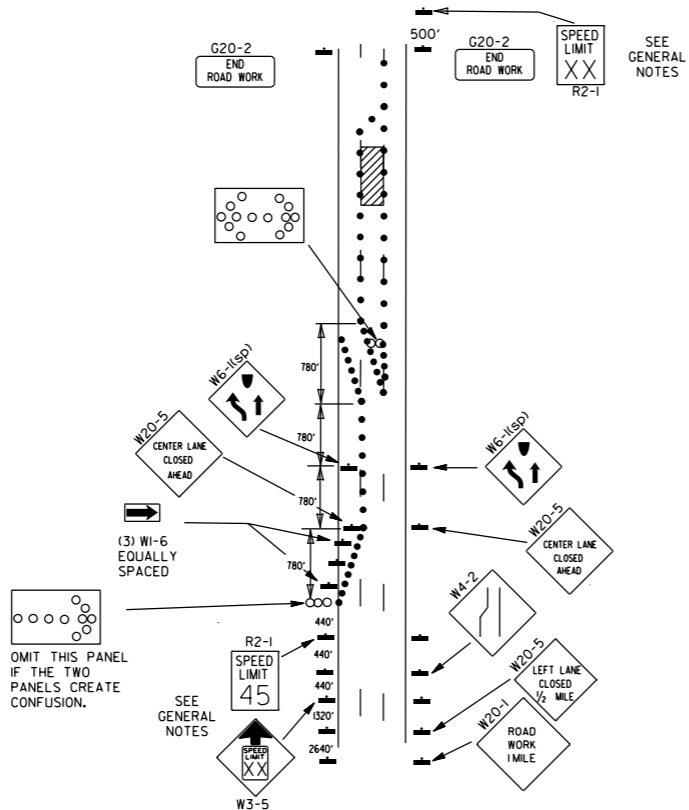

(B) TYPICAL APPLICATION - 3-LANE ONEWAY ROADWAY WHERE CENTER LANE IS CLOSED.

CHANNELIZING DEVICES

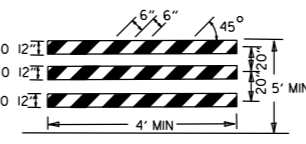
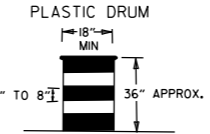
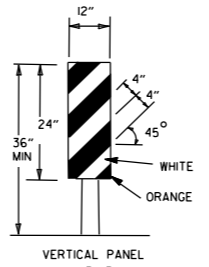
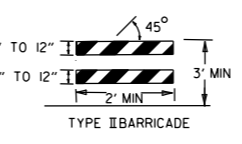
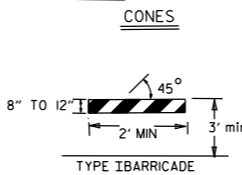
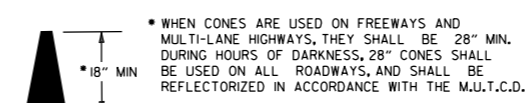

NOTE: FOR ALL ROAD CLOSURES, THE TYPE III BARRICADES SHALL BE OF SUFFICIENT LENGTH TO EXTEND ACROSS ENTIRE ROADWAY.

VERTICAL PANEL PLACEMENT

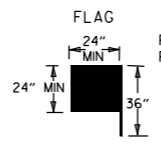
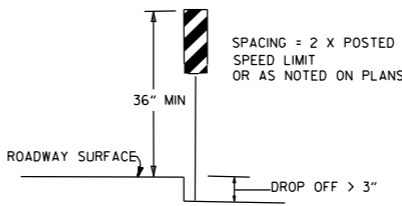

FLAG SHALL BE OF GOOD GRADE RED MATERIAL

- KEY:
- ○ ○ ARROW PANEL (IF REQUIRED)
 - CHANNELIZING DEVICE
 - TRAFFIC DRUM

GENERAL NOTES:

1. A SPEED LIMIT REDUCTION MAY BE IMPLEMENTED ONLY WHEN DESIGNATED IN THE PLAN OR WHEN RECOMMENDED BY THE ROADWAY DESIGN DIVISION.
2. WHEN THE EXISTING SPEED LIMIT IS 55MPH AND THE PLANS REQUIRE A SPEED LIMIT OF 45MPH, THE R2-(55) SHALL BE OMITTED AND THE W3-5 SHALL BE INSTALLED AT THAT LOCATION. ADDITIONAL R2-145MPH SPEED LIMIT SIGNS SHALL BE INSTALLED AT A MAXIMUM OF 1/4 MILE INTERVALS. AT THE END OF THE WORK AREA A R2-(XX) SHALL BE INSTALLED TO MATCH ORIGINAL SPEED LIMIT.
3. WHEN THE EXISTING SPEED LIMIT IS 65MPH AND THE PLANS REQUIRE A SPEED LIMIT OF 55MPH, THE R2-(65) SHALL BE OMITTED. ADDITIONAL R2-155MPH SPEED LIMIT SIGNS SHALL BE INSTALLED AT A MAXIMUM OF 1/4 MILE INTERVALS. AT THE END OF THE WORK AREA A R2-(XX) SHALL BE INSTALLED TO MATCH ORIGINAL SPEED LIMIT.
4. THE MAXIMUM SPACING BETWEEN CHANNELIZING DEVICES IN A TAPER SHOULD BE APPROXIMATELY EQUAL IN FEET TO THE SPEED LIMIT. BEYOND THE TAPER, MAXIMUM SPACING SHALL BE TWO TIMES THE SPEED LIMIT OR AS DIRECTED BY THE ENGINEER.
5. WARNING LIGHTS AND/OR FLAGS MAY BE MOUNTED TO SIGNS OR CHANNELIZING DEVICES AT NIGHT AS NEEDED.
6. PAVEMENT MARKINGS NO LONGER APPLICABLE WHICH MIGHT CREATE CONFUSION IN THE MINDS OF VEHICLE OPERATORS SHOULD BE REMOVED OR OBLITERATED AS SOON AS PRACTICABLE.
7. THE G20-1 SIGN WILL BE REQUIRED ON JOBS OF OVER TWO MILES IN LENGTH. WHEN THE LANE CLOSURE IS NOT AT THE BEGINNING OF THE PROJECT, THE G20-1 SIGN SHALL BE ERECTED 125' IN ADVANCE OF THE JOB LIMIT. ADDITIONAL W20-1 (1 MILE) SIGNS ARE NOT REQUIRED IN ADVANCE OF LANE CLOSURES THAT BEGIN INSIDE THE PROJECT LIMITS.
8. FLAGGERS SHALL USE STOP/SLOW PADDLES FOR CONTROLLING TRAFFIC THROUGH WORK ZONES. FLAGS MAY BE USED ONLY FOR EMERGENCY SITUATIONS.
9. ALL PLASTIC DRUMS AND CONES SHALL MEET THE REQUIREMENTS OF MANUAL FOR ASSESSING SAFETY HARDWARE (MASH).
10. TRAILER MOUNTED DEVICES SUCH AS ARROW PANELS AND PORTABLE CHANGEABLE MESSAGE SIGNS SHALL BE DELINEATED BY AFFIXING CONSPICUITY MATERIAL IN A CONTINUOUS LINE ON THE FACE OF THE TRAILER. WHEN PLACED ON OR ADJACENT TO THE SHOULDER AND NOT BEHIND A POSITIVE BARRIER, THESE DEVICES SHALL BE DELINEATED BY PLACING FIVE (5) TRAFFIC DRUMS, EQUALLY SPACED ALONG THE TRAFFIC SIDE OF THE DEVICE. PAYMENT FOR TRAFFIC DRUMS SHALL BE CONSIDERED INCLUDED IN THE PRICE BID FOR VARIOUS TRAILER MOUNTED DEVICES.
11. ALL TRAILER MOUNTED DEVICES SUCH AS ARROW PANELS AND PORTABLE CHANGEABLE MESSAGE SIGNS SHALL MEET THE REQUIREMENTS OF THE MANUAL FOR ASSESSING SAFETY HARDWARE (MASH).

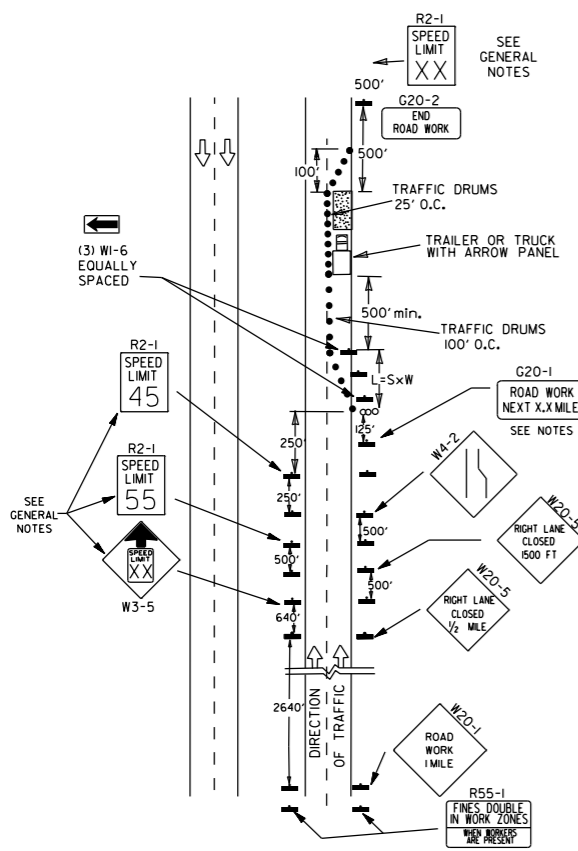

(C) TYPICAL APPLICATION - CONSTRUCTION OPERATIONS OF INTERMEDIATE TO LONG TERM DURATION ON A 4-LANE DIVIDED ROADWAY WHERE HALF OF THE ROADWAY IS CLOSED.

TRAFFIC CONTROL DEVICES			
VERTICAL DIFFERENTIAL	LOCATION	TRAFFIC CONTROL	
		≤ 45 MPH	> 45 MPH
≤ 1"	CENTERLINE	W8-11	W8-11
> 1" ≤ 3"	CENTERLINE	W8-11 AND CENTERLINE LANE STRIPING	W8-11 AND CENTERLINE LANE STRIPING
> 3"	CENTERLINE	STANDARD LANE CLOSURE ⁽⁶⁾	STANDARD LANE CLOSURE ⁽⁶⁾
≤ 3"	EDGE OF TRAVELED LANE OR EDGE OF SHOULDER	W8-9 AND TRAFFIC DRUMS ⁽¹⁾	W8-9 AND TRAFFIC DRUMS ⁽¹⁾
> 3"	EDGE OF TRAVELED LANE OR EDGE OF SHOULDER	W8-17, EDGE LINE STRIPING, AND TRAFFIC DRUMS ⁽¹⁾	W8-17, EDGE LINE STRIPING, AND TRAFFIC DRUMS ⁽¹⁾
> 6"	EDGE OF TRAVELED LANE OR EDGE OF SHOULDER	W8-17, EDGE LINE STRIPING, AND TRAFFIC DRUMS ⁽¹⁾	W8-17, EDGE LINE STRIPING, AND TRAFFIC DRUMS ⁽²⁾
> 18" ≤ 24"	EDGE OF TRAVELED LANE OR EDGE OF SHOULDER	W8-17, EDGE LINE STRIPING, AND TRAFFIC DRUMS ⁽¹⁾	A STABILIZED WEDGE, W8-17, EDGE LINE STRIPING AND TRAFFIC DRUMS ⁽³⁾
> 24"	EDGE OF TRAVELED LANE OR EDGE OF SHOULDER	PRECAST CONCRETE BARRIER ⁽⁴⁾ & EDGE LINES	PRECAST CONCRETE BARRIER ⁽⁴⁾ & EDGE LINES

INTERSTATE		
VERTICAL DIFFERENTIAL	LOCATION	TRAFFIC CONTROL
≤ 3"	CENTERLINE	W8-11 AND LANE STRIPING
≤ 3"	EDGE OF TRAVELED LANE OR EDGE OF SHOULDER	W8-9, EDGE LINE STRIPING, AND TRAFFIC DRUMS ⁽²⁾
> 3"	EDGE OF TRAVELED LANE OR EDGE OF SHOULDER	W8-17, EDGE LINE STRIPING, AND TRAFFIC DRUMS ⁽²⁾
> 6"	EDGE OF TRAVELED LANE OR EDGE OF SHOULDER	PRECAST CONCRETE BARRIER & EDGE LINES

INTERSTATE AND NON-INTERSTATE		
FORESLOPE	HEIGHT	TRAFFIC CONTROL
1:1	> 2 FT	PRECAST CONCRETE BARRIER
2:1	≤ 5 FT	TRAFFIC DRUMS
2:1	> 5 FT	PRECAST CONCRETE BARRIER
Flatter than 2:1	N/A	TRAFFIC DRUMS

- GENERAL NOTES:
1. WHEN THE SHOULDER AREA IS USED AS PART OF THE TRAVELED LANE AND THERE IS INSUFFICIENT WIDTH TO PLACE TRAFFIC DRUMS ON THE REMAINING SHOULDER WIDTH, THEN VERTICAL PANELS SHALL BE USED.
 2. WHEN THERE IS INSUFFICIENT WIDTH TO PLACE TRAFFIC DRUMS ON THE REMAINING SHOULDER WIDTH, A STABILIZED WEDGE SHALL BE USED.
 3. PRECAST CONCRETE BARRIER WALL CAN BE USED IN LIEU OF A STABILIZED WEDGE, W8-17 SIGN, EDGE LINE STRIPING, AND TRAFFIC DRUMS, IF AND WHERE DIRECTED BY THE ENGINEER.
 4. A STABILIZED WEDGE, W8-17 SIGN, EDGE LINE STRIPING, AND TRAFFIC DRUMS CAN BE USED IN LIEU OF PRECAST CONCRETE BARRIER WALL, IF AND WHERE DIRECTED BY THE ENGINEER.
 5. W21-5, W21-50, AND/OR W21-5b SIGNS SHALL BE USED WHERE THE ROADWAY IS UNOBSTRUCTED IF AND WHERE DIRECTED BY THE ENGINEER. TIME LIMITATIONS MUST CONFORM TO SECTION 603 OF THE STANDARD SPECIFICATIONS FOR HIGHWAY CONSTRUCTION (CURRENT EDITION).

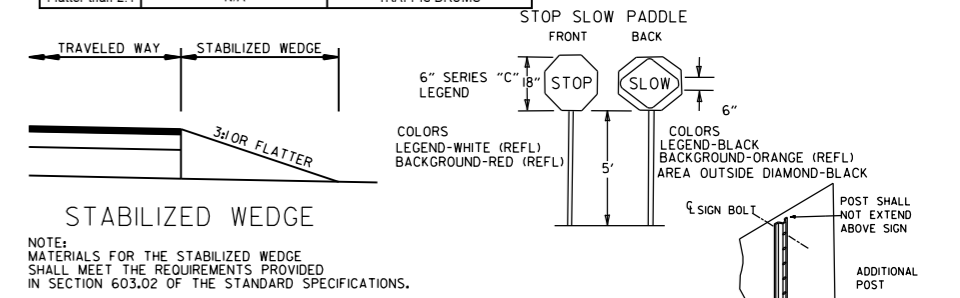

STABILIZED WEDGE

NOTE: MATERIALS FOR THE STABILIZED WEDGE SHALL MEET THE REQUIREMENTS PROVIDED IN SECTION 603.02 OF THE STANDARD SPECIFICATIONS.

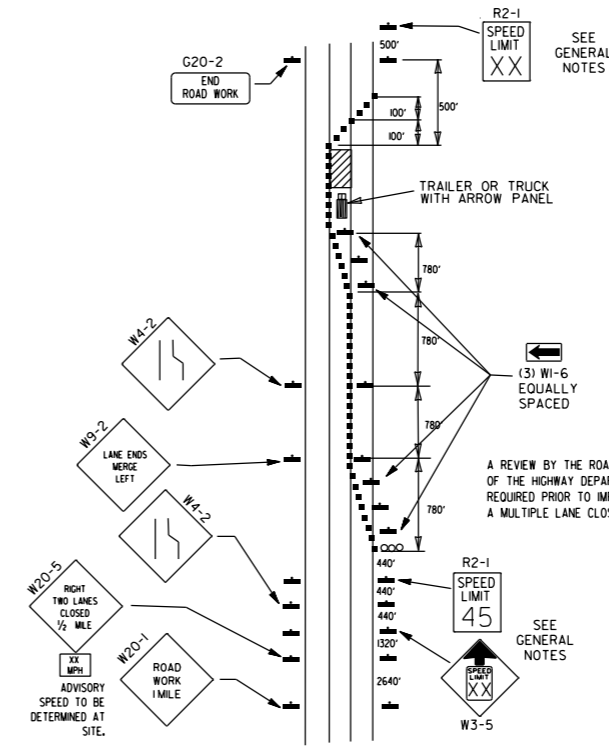

(D) TYPICAL APPLICATION - CLOSING MULTIPLE LANES OF A MULTILANE HIGHWAY.

NOTES: USE SPLICES ONLY WHEN NECESSARY FOR INSTALLATION. TYPICAL INSTALLATION SHOULD HAVE NO SPLICES (SEE STD. DRAWING NO. 5HS-2)

NORMAL INSTALLATIONS WILL REQUIRE 1/4\"/>

SIGN POSTS SHALL BE PAINTED GREEN; SIGNS SHALL NOT BE PAINTED, AND ALL SIGN POSTS SHALL BE PLUMB.

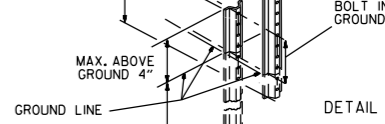

DETAIL OF SPLICES

DATE	REVISION	FILED
08-12-21	REVISED TRAFFIC CONTROL DEVICES AND NOTES	
05-20-21	REVISED NOTE 10	
2-27-20	REVISED TRAFFIC CONTROL DEVICES DETAILS	
11-07-19	REVISED NOTE 9, ADDED NOTE 11	
7-25-19	REVISED TRAFFIC CONTROL DEVICES DETAILS	
9-2-15	REVISED NOTE 2 & REPLACED R2-5A WITH W3-5	
10-15-09	ADDED REFERENCE TO MASH	
11-20-08	REVISED SIGN DESIGNATIONS	
11-18-04	ADDED NOTE	
10-1-98	ADDED NOTE	
4-03-97	ADDED (SP) TO W6-18 & REVISED TRAFFIC CONTROL DEVICES NOTE	
10-18-96	ADDED R55-1	
10-12-95	MOVED UPPER SPLICE	
6-8-95	REVISED SPLICE DETAIL, TEXT	6-8-95
2-2-95	REVISED PER PART VI, MUTCD, SEPT. 3, 1993	
8-15-91	DRAWN AND PLACED IN USE	

REINFORCING BAR TABLE PER BARRIER UNIT			
MARK	LOCATION	BAR SIZE (NO. BARS)	SKETCH
H-1	HORIZONTAL IN BARRIER TIED INSIDE V-1 BARS	#5 (6)	19'-3"
H-2	CENTERED ABOVE DRAIN SLOTS LONG. & TRANSVERSELY	#5 (6)	6'-6"
H-3	TIED ABOVE H-1 BARS TO SUPPORT H-2, TIED TO V-1	#4 (2)	1'-6"
S-1	OVER LIFT HOLES	#4 (2)	2'-5" 3/8" R 90°
S-2	HORIZ. AROUND SLOTS BETWEEN V-1'S & DRAIN SLOTS	#4 (2)	1 1/2" R SLOTS 1" MIN. CLEAR TO BAR TO BAR 5'-1" BAR W/ (4) 1 1/2" R BENDS & MIN. 1'-0" OVERLAP
V-1	VERTICAL IN BARRIER (3) EACH END & (2) AT EACH DRAIN SLOTS	#5 (16)	TOTAL LENGTH 4'-9" 2 3/16" R 12° 4 3/8" 2'-1 3/8" 3/8"

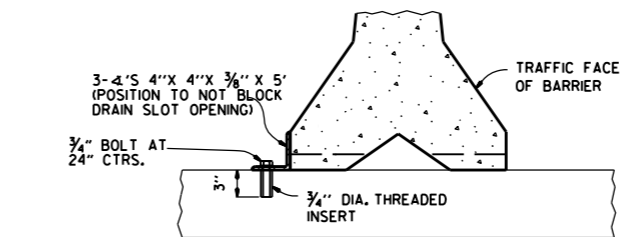
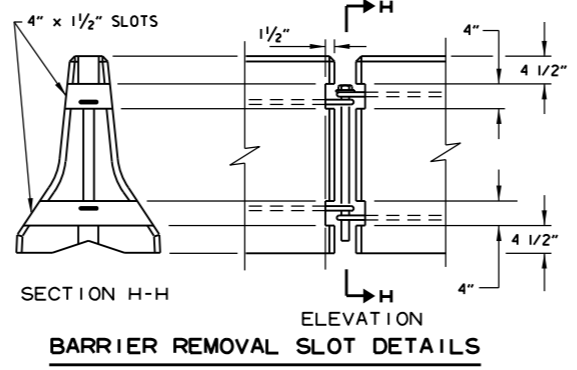
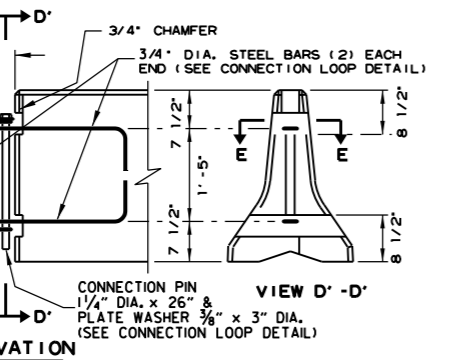
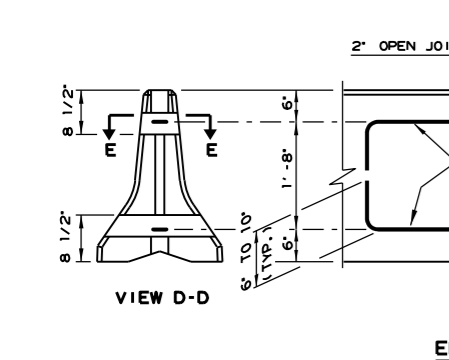
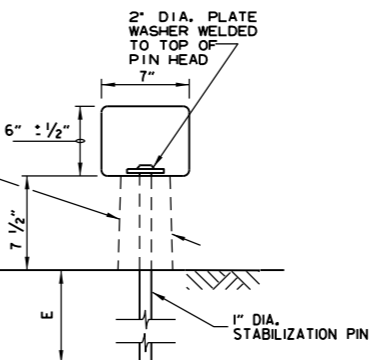
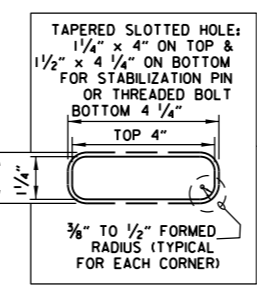
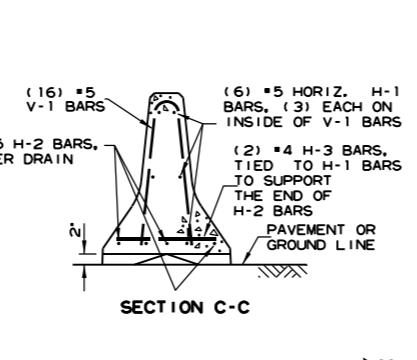
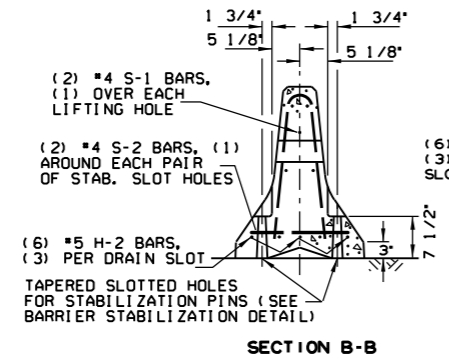
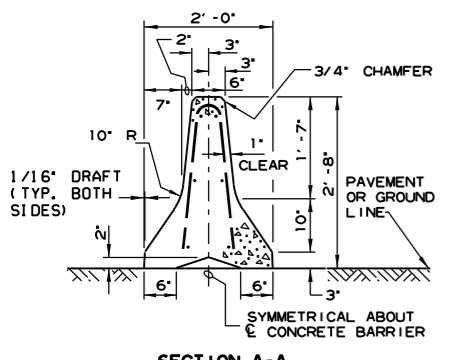
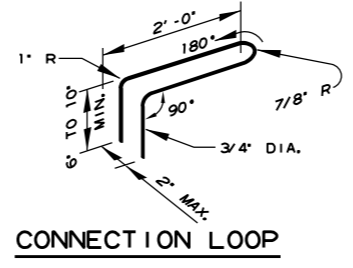
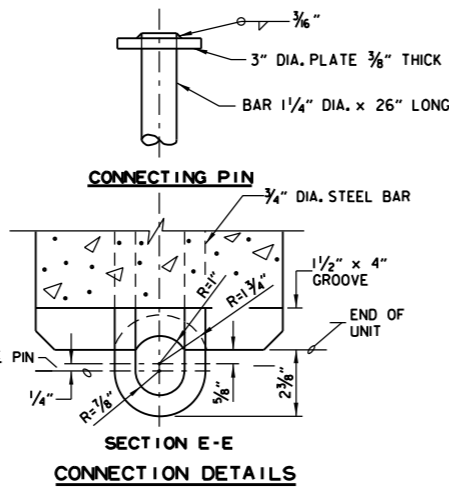

NOTE: THREADED INSERTS SHALL BE CAST IN PLACE FOR ALL NEW BRIDGE DECKS AND DRILLED AND GROUDED FOR EXISTING BRIDGE DECKS. INSERTS SHALL HAVE A MINIMUM ULTIMATE LOAD CAPACITY OF 8000 LBS. IN TENSION. AFTER REMOVAL OF BARRIER, BOLTS, AND ANGLES, THE INSERTS SHALL BE FILLED WITH APPROVED NON-SHRINK EPOXY.

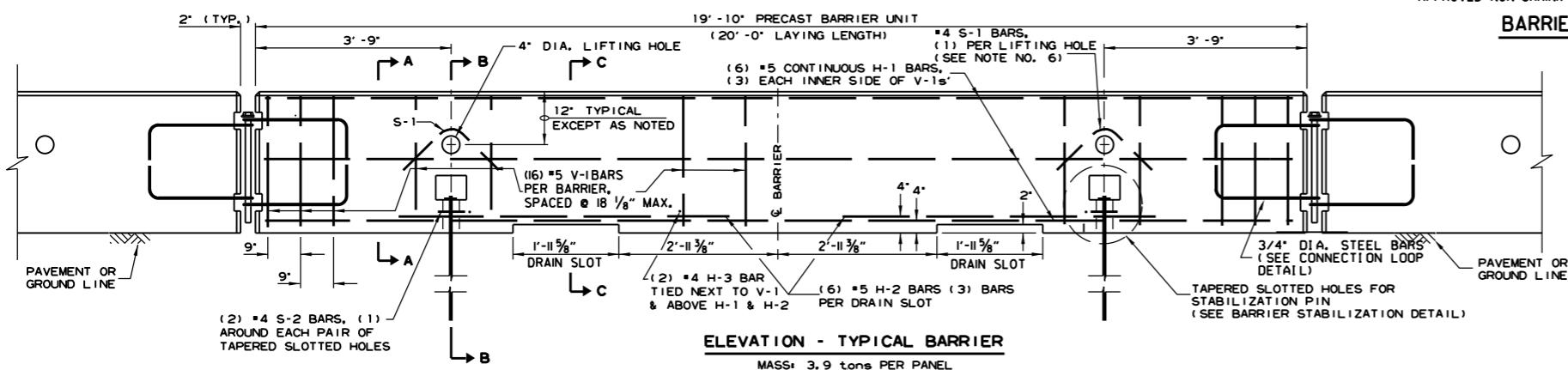

- GENERAL NOTES**
- THE CONTRACTOR SHALL FURNISH THE PRECAST CONCRETE BARRIER UNITS AND SHALL BE RESPONSIBLE FOR THE MANUFACTURE, SHIPMENT, STORAGE, PLACEMENT AND REMOVAL. AT THE COMPLETION OF THE PROJECT, THE PRECAST UNITS WILL REMAIN THE PROPERTY OF THE CONTRACTOR.
 - MATERIALS SHALL MEET THE FOLLOWING MINIMUM REQUIREMENTS:
 CONCRETE: 2500 PSI COMPRESSIVE STRENGTH AT 28 DAYS.
 REINFORCING STEEL: AASHTO M 31 OR M 53, GRADE 60
 STRUCTURAL STEEL: AASHTO-M270 GRADE 36 SHALL BE USED FOR THE CONNECTION PIN, CONNECTION LOOPS, AND STABILIZATION PINS. A ONE PIECE PIN WITH A 3" ROUNDED TOP MAY BE USED IN PLACE OF THE DETAILED CONNECTION PIN.
 DELINEATORS: DELINEATORS SHALL BE MOUNTED AT 10' SPACING ON TOP OF PRECAST BARRIER.
 IN APPLICATIONS WHERE BARRIER WALL IS WITHIN 6 FEET OF A TRAFFIC LANE, ADDITIONAL DELINEATORS SHALL BE PLACED ON THE BARRIER AT 10' SPACING APPROXIMATELY ONE (1) FOOT FROM THE TOP OF THE BARRIER. DELINEATORS SHALL BE ON THE ARDOT QUALIFIED PRODUCTS LIST FOR CONSTRUCTION CONCRETE BARRIER MARKERS. DELINEATOR COLOR SHALL BE IN ACCORDANCE WITH THE MANUAL ON UNIFORM TRAFFIC CONTROL DEVICES. PAYMENT FOR DELINEATORS SHALL BE CONSIDERED INCLUDED IN THE PRICE BID PER LIN. FT. FOR "FURNISHING AND INSTALLING PRECAST CONCRETE BARRIER". THE CONTRACTOR SHALL CERTIFY TO THE ENGINEER THAT THE MATERIAL AND THE DESIGN USED IN THE PRECAST BARRIER UNITS MEETS THE REQUIREMENTS AS SHOWN ON THIS STANDARD DRAWING.
 - OTHER PRECAST CONCRETE BARRIERS THAT HAVE BEEN CRASH TESTED AND APPROVED BY THE FEDERAL HIGHWAY ADMINISTRATION TO MEET THE REQUIREMENTS OF MANUAL FOR ASSESSING SAFETY HARDWARE (MASH) WILL BE ACCEPTED OR AS DIRECTED BY THE ENGINEER. THE CONTRACTOR SHALL FURNISH A CERTIFICATION OF MANUAL FOR ASSESSING SAFETY HARDWARE (MASH) COMPLIANCE FOR ANY OTHER TYPES OF PRECAST BARRIER TO BE USED. THE CERTIFICATION SHALL STATE THAT THE PRECAST CONCRETE BARRIER MEETS THE REQUIREMENTS OF MANUAL FOR ASSESSING SAFETY HARDWARE (MASH). MIXING OF SHAPES WILL NOT BE ALLOWED IN A CONTINUOUS LINE OF UNITS.
 - DOWEL HOLES IN PAVEMENT OR BRIDGE SLABS THAT ARE TO REMAIN IN PLACE SHALL BE FILLED. HOLES IN CONCRETE PAVEMENT AND BRIDGE SLABS SHALL BE FILLED WITH AN APPROVED NON-SHRINK EPOXY GROUT. HOLES IN ASPHALT PAVEMENT SHALL BE FILLED WITH AN APPROVED ASPHALT JOINT FILLER. PAYMENT FOR DRILLING AND FILLING HOLES TO BE INCLUDED IN THE PRICE FOR VARIOUS BARRIER ITEMS.
 - ATTACH UNITS TO ROADWAY SURFACE WITH STABILIZATION PINS AND TO DECK SLABS USING BOLTS WHEN REQUIRED.
 - A 4" WHITE PVC SLEEVE MAY BE USED TO FORM THE LIFTING HOLE AND IF USED THE SLEEVE IS TO BE LEFT IN PLACE.

DATE	REVISION	FILMED
11-07-19	REVISED NOTE 3	
2-27-14	REVISED BARRIER STABILIZATION DETAIL	
10-15-09	ADDED REFERENCE TO MASH	
8-5-09	REV. NOTE 3 CONCERNING DRAIN SLOTS	
11-29-07	REVISED NOTE 3	
5-25-06	DELETED GENERAL NOTE 7	
11-18-04	REVISED BARRIER STABILIZATION DETAIL BRIDGE DECKS	
4-10-03	REVISED GENERAL NOTE 2	
8-22-02	ISSUED NEW DRAWING	

ARKANSAS STATE HIGHWAY COMMISSION
 STANDARD TRAFFIC CONTROLS
 FOR HIGHWAY CONSTRUCTION -
 TEMPORARY PRECAST BARRIER
 STANDARD DRAWING TC-4

(A) 4 feet or greater preferred. If less than 4 feet, Precast Units shall be connected to slab (SEE BARRIER STABILIZATION DETAIL-BRIDGE DECKS STD. DRWG. TC-4)

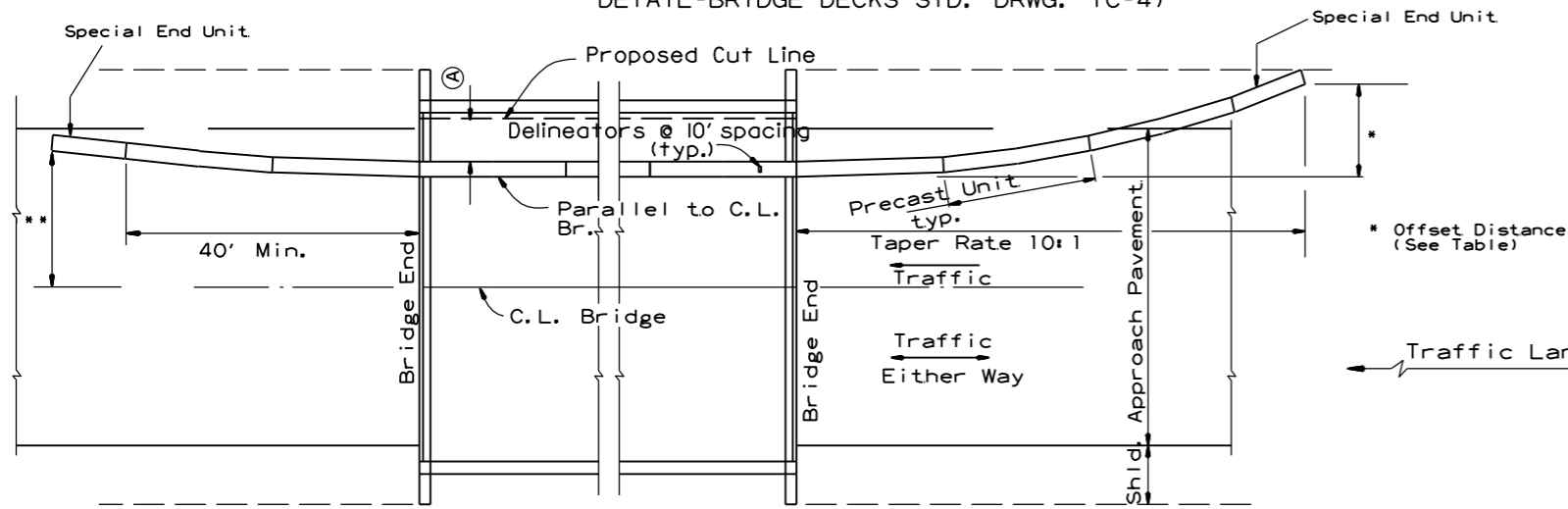

BARRIER PLACEMENT ALONG BRIDGE WITH OFFSET

No Scale

** Offset Distance for Two Way Traffic Only

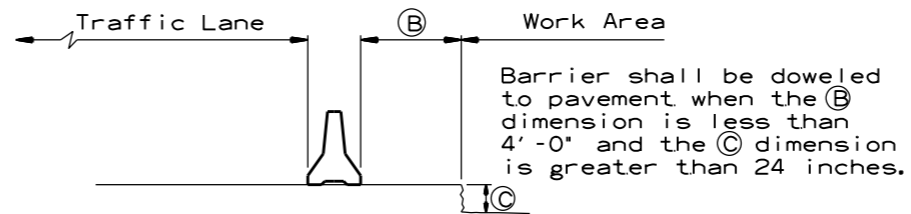

SECTION J-J

No Scale

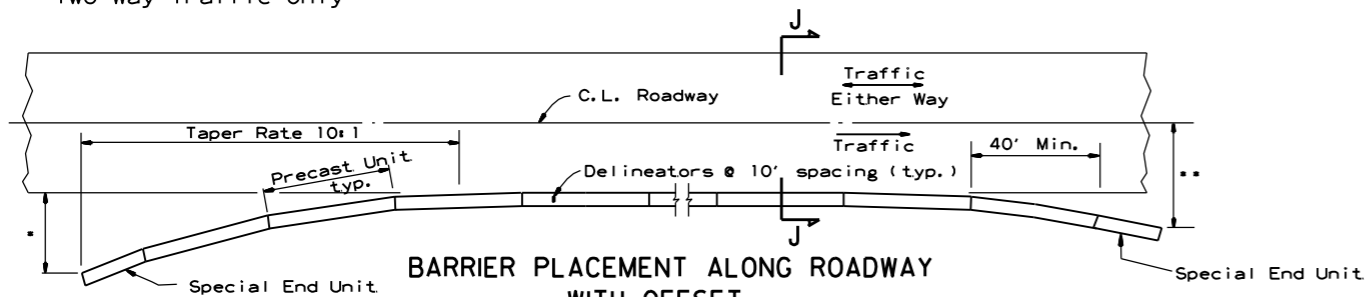

BARRIER PLACEMENT ALONG ROADWAY WITH OFFSET

No Scale

* Offset Distance (See Table)

** Offset Distance For Two Way Traffic Only

Offset Distance Table

Speed (MPH)	Offset Distance (FT.)
≤ 45	12
> 45	18

If offset distance is not attainable, then see 'Barrier Placement With Attenuator' Detail shown below.

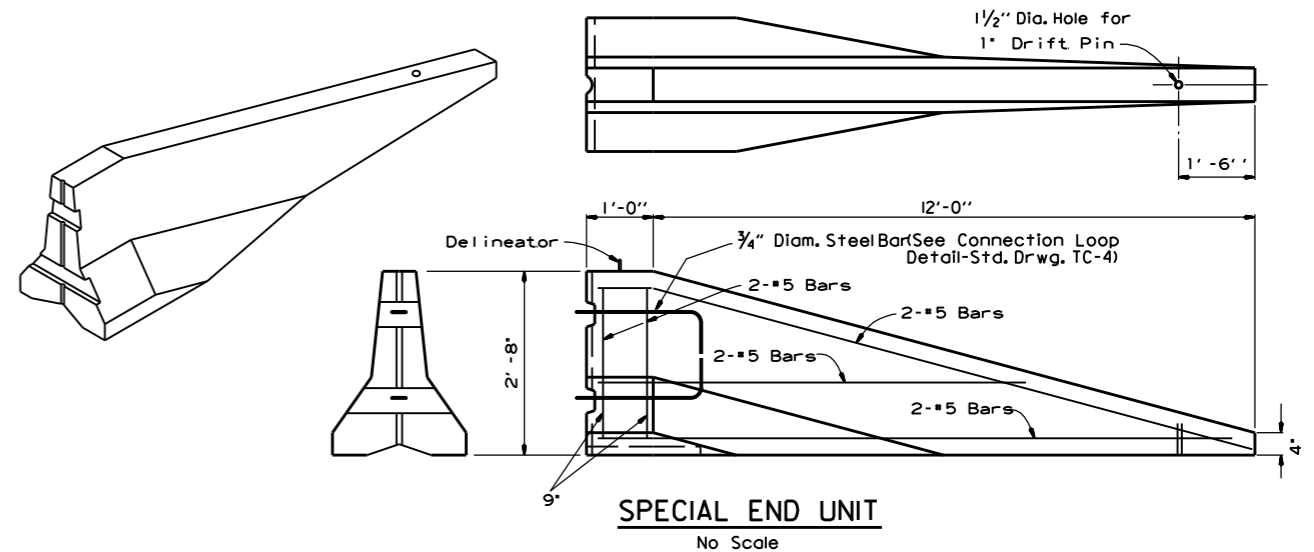

SPECIAL END UNIT

No Scale

General Notes

When shown on the Plans, the ends of the Temporary Precast Concrete Barrier shall be protected with a Manual For Assessing Safety Hardware (MASH) approved Crash Cushion. Payment for Crash Cushions shall be made under the item of "Temporary Impact Attenuation Barrier."

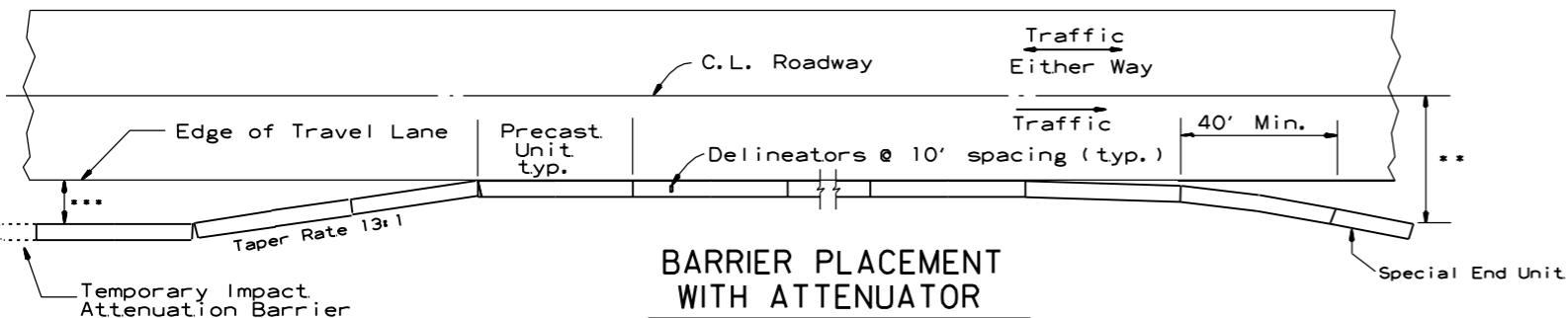

BARRIER PLACEMENT WITH ATTENUATOR

No Scale

** Offset Distance For Two Way Traffic Only

*** Min. 3'-0" From Edge of Travel Lane to Nearest Edge of Attenuator

DATE	REVISION	FILMED
11-07-19	REVISED NOTE	
10-15-09	ADDED REFERENCE TO MASH	
5-25-06	REVISED BARRIER PLACEMENT	
8-22-02	ISSUED NEW DRAWING	

ARKANSAS STATE HIGHWAY COMMISSION

**STANDARD TRAFFIC CONTROLS
FOR HIGHWAY CONSTRUCTION -
TEMPORARY PRECAST BARRIER**

STANDARD DRAWING TC-5